



TYPICAL

TW1-898L14D2T5

**1-NEEDLE DIRECT DRIVE COMPOUND
FEED SEWING MACHINE**

TW2-898L14D2T5

**2-NEEDLE DIRECT DRIVE COMPOUND
FEED SEWING MACHINE**

**OPERATION INSTRUCTION / PARTS MANUAL
AC SERVO SYSTEM SERVICE MANUAL**

- Please don't adjust and repair the machine by non-professionals, except adjusting stitch.
- Specifications subject to change without notice

TYPICAL SEWING MACHINE WANPING MACHINERY CO.,LTD.

ADD: WANPING TOWN, WUJIANG CITY, JIANGSU
PROVINCE, CHINA

TEL: +86-512-63391278

FAX: +86-512-63391371

POST. CODE: 215223

Http://www.typicalwpchina.com

E-mail: export@typicalwpchina.com

2018.03

CONTENTS

Operation Instruction

1. Brief introduction.....	1
2. Main specifications.....	1
3. Installing hinge and cushion.....	1
4. Installing the oil pan.....	1
5. Installing the machine head.....	2
6. Installing the operation panel	2
7. Setting the machine ID	3
8. Changeover between normal pedal and standing pedal.....	3
9. Adjusting the start position.....	4
10. Installing pneumatic mechanisms.....	5
11. Adjusting pneumatic pressure.....	6
12. Installing the thread stand.....	6
13. Installing the knee lifter.....	6
14. Lubrication.....	7
15. Rotating direction of pulley.....	8
16. Installing the needle.....	8
17. Removing the bobbin.....	9
18. Winding the bobbin thread.....	9
19. Installing the bobbin.....	10
20. Threading the upper thread.....	11
21. Adjusting the stitch length.....	11
22. Alternating presser foot movement amount.....	12
23. Using the manual switches.....	13
24. Backtacking.....	14
25. Thread tension.....	14
26. Adjusting the presser foot pressure.....	15
27. Adjusting the trailing length after thread trimming	15
28. Clearing.....	16
29. Checking.....	16
30. Draining water from the air system	17
31. Cleaning the oil filter.....	17
32. Adjusting the thread tension spring.....	17
33. Adjusting the feed dog height.....	18
34. Adjusting the needle bar height.....	18
35. Needle and rotary hook timing.....	19
36. Adjusting clearance between needle and rotary hook tip.....	19
37. Adjusting the needle guard position.....	20
38. Adjusting the needle and feed mechanism timing.....	20
39. Adjusting the opener	21
40. Adjusting the presser foot height.....	23
41. Adjusting the alternating presser foot movement amount.....	24
42. Adjusting the presser foot timing.....	25
43. Adjusting the fixed knife position.....	25
44. Adjusting the knife timing position.....	26
45. Height of the driving knife.....	26
46. Stop position of the driving knife.....	27
47. Adjusting the driving knife operation position.....	28
48. Adjusting the thread holding spring position	29
49. Adjusting the thread trimming timing	29
50. Adjusting the rotary hook lubrication amount	30
51. Removing the timing belt.....	30
52. Installing the timing belt.....	32
53. Change of needle gauge parts	34
54. Change 1–needle gauge parts to 2–needle set	35
55. Safety equipment.....	38

CONTENTS

Parts Manual

1. Machine body.....	39-40
2. Upper shaft mechanism.....	41-42
3. Upper feed mechanism.....	43
4. Quick reverse mechanism.....	44
5. Needle bar and thread take-up mechanism.....	45-46
6. Presser bar mechanism.....	47-48
7. Feed mechanism.....	49-50
8. Presser foot adjusting mechanism.....	51-52
9. Alternating presser foot lifter mechanism.....	53
10. Quick reverse mechanism.....	54
11. Upper feed mechanism.....	55-56
12. Feed shaft mechanism.....	57-58
13. Motor mechanism.....	59
14. Needle plate, presser foot	60
14. Needle plate, presser foot (2-needle machine).....	61-62
15. Rotary hook shaft timing mechanism.....	63-64
15. Rotary hook shaft timing mechanism(2-needle machine).....	65-66
16. Lower shaft mechanism.....	67-68
16. Lubrication mechanism.....	69-70
17. Lubrication mechanism (2-needle machine).....	71-72
18. Bobbin winder mechanism.....	73-74
19. Thread trimmer mechanism.....	75-76
19. Thread trimmer mechanism (2-needle machine).....	77-78
20. Thread tension mechanism(1-needle machine).....	79-80
20. Thread tension mechanism (2-needle machine).....	81-82
21. Manual switch mechanism.....	83
22. Air presser mechanism.....	84
23. Presser foot actuator mechanism.....	85-86
24. Accessories.....	87-88

Operation Instruction

1. Brief introduction

This series of flatbed sewing machines feature direct drive, electric handwheel, the second tension release, automatic thread trimmer, automatic bartack, automatic presser foot lifter, walking foot movement changeover, and stitch length quick change.

The said machines are equipped with pneumatic presser foot lifter and bartack, large dial mounted on machine head for easy setting of walking foot movement and sewing speed. Reverse feeding, auto bartack and alternate stitch can be easily set. Automatic lubrication system, long durability and smooth running.

Suitable for sewing such as automobile upholstery, covers, awnings, tents, luggage, travelwares accessories, sports and camping equipment, apparel and outdoor clothing.

2. Main specifications

Mode	TW1-898L14D2T5	TW2-898L14D2T5
Max speed	3500s. p. m.	2800s. p. m.
Max stitch Length	9mm	
Presser height	By hand	≥9mm
	By knee	≥16mm
	Auto lifter	≥16mm
Amount of walking foot movement	1~7mm	
Needle	DP×17 19 [#] -23 [#]	
Needle Gauge	3, 4, 6, 8, 10, 12mm	

Sewing speed range

Amount of walking foot movement	Stitch length	
	≤6mm	6~9mm
1~2mm	3500s. p. m.	2000s. p. m.
3mm	3000s. p. m.	
4mm	2500s. p. m.	
5~6mm	2000s. p. m.	

Note: Sewing speeds should be subject to amounts of walking foot movement shown in the left column of the table.

3. Installing hinge and cushion(fig.1)

1. Insert rubber cushion ① into the notch in the cutout of the table and fix with nail ②.
2. Fix cushion ③.
3. Fix cushion ④ with nail ②.

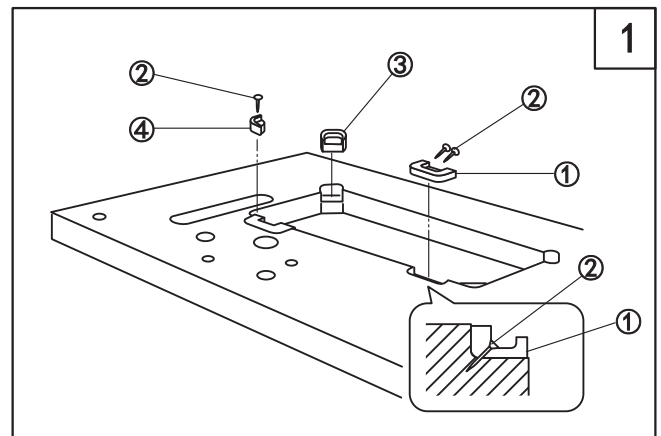

4. Installing the oil pan(fig.2)

Install the oil pan ① to the underside of the table ③ in the place shown in the illustration using the screws ②.

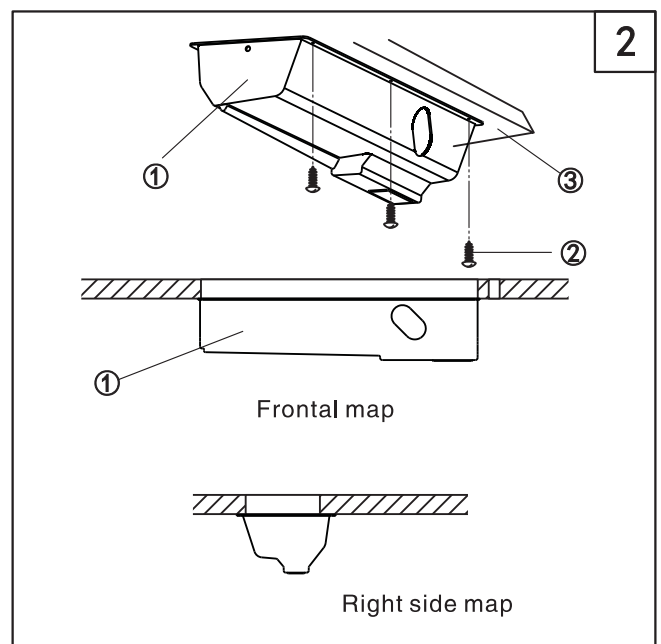

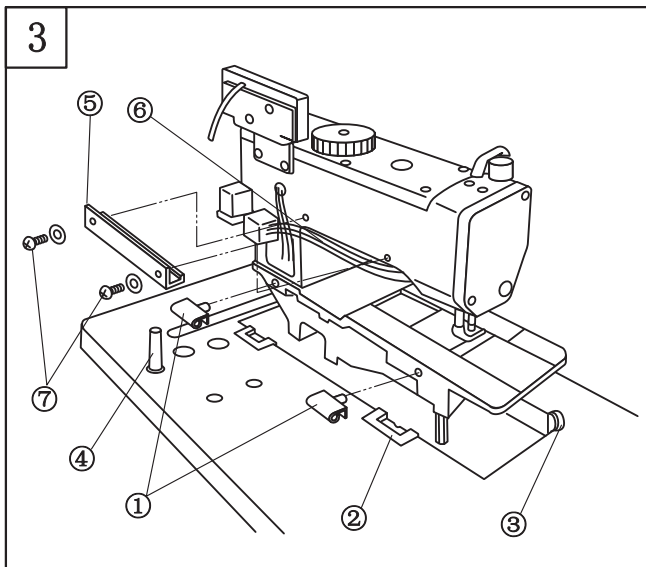

5. Installing the machine head(fig.3、 4)

1. Insert the head hinge ① into the bed holes of the machine head
2. Fit hinge ① to the rubber hinge ②, then stand machine head on the rubber cushions ③
3. Set support rod ④ to the table
4. Arrange and put wires ⑥ inside of cover ⑤, then fix it by screw ⑦.
5. Connect the returned oil tube⑧ with oil nozzle of oil pan ⑨

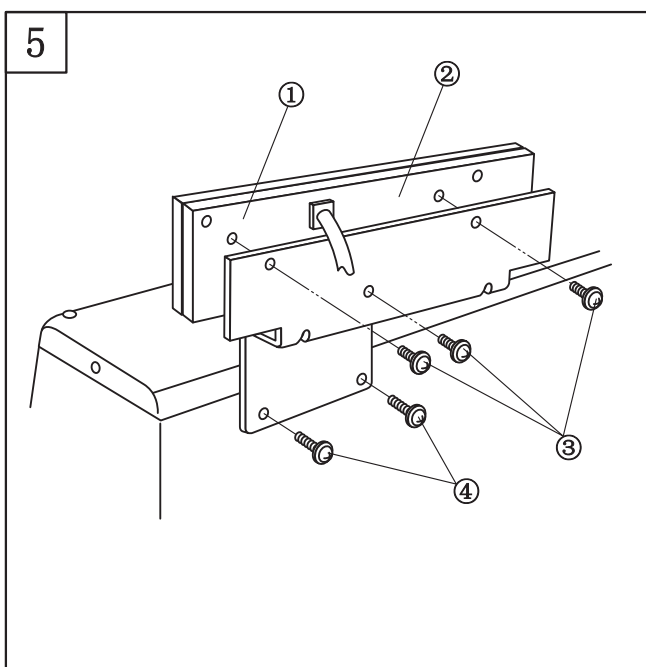
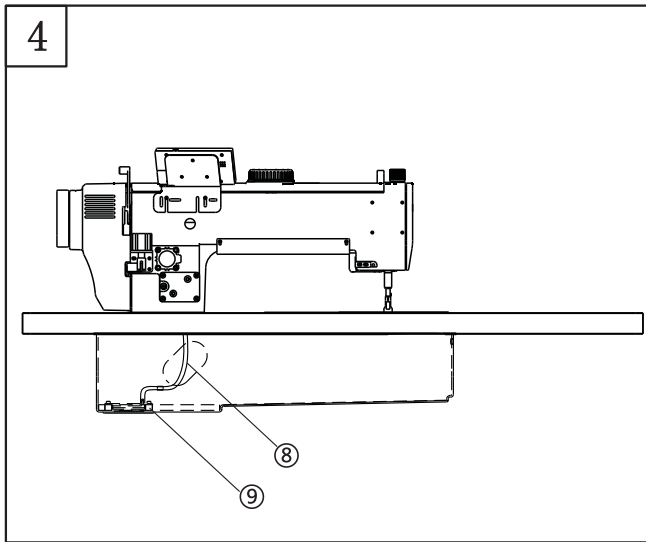

6. Installing the operation panel (fig.5)

1. Install the panel ① on the plate ② with screw ③
2. Fix the plate ② on the machine back with screw ④.

6

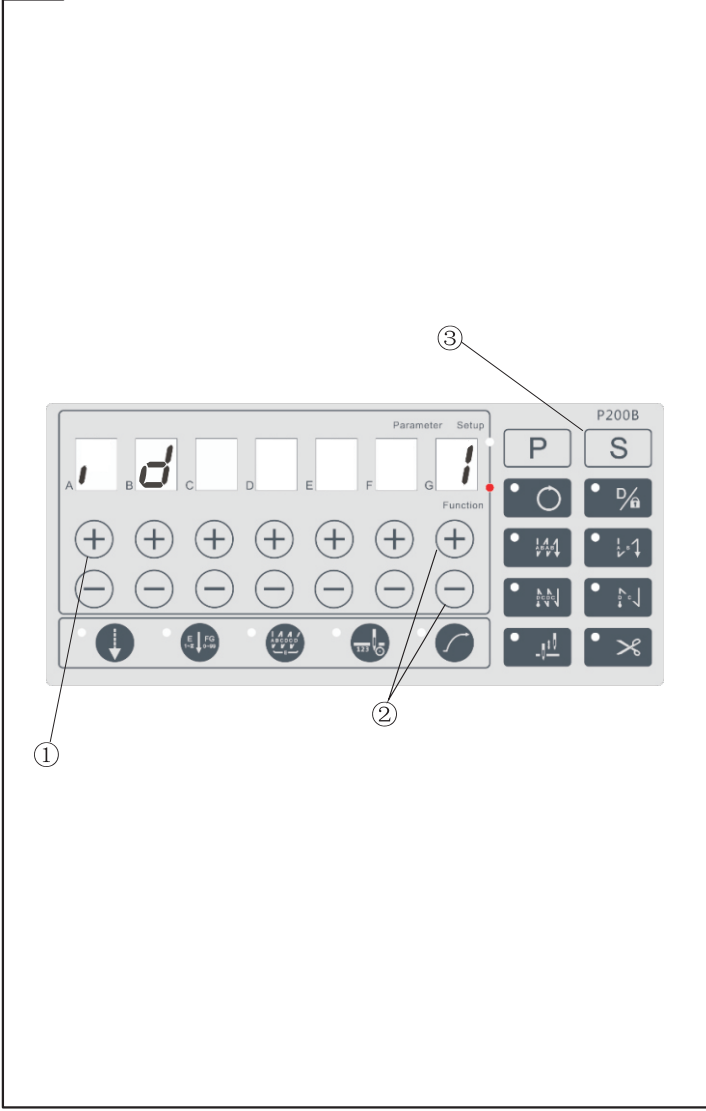

7. Setting the machine ID (fig 6).

NOTE; 1. When start to use, please set the machine ID first
 2.For control system YSC-8361 only

- 1.Press the key "+" ①, and power on
- 2.Adjust the keys "+/-" ② ,to number "4"(1-needle machine) or "8"(2-needle machine) then press key "S" ③ to save
- 3.Restart the system

ID	MODEL	MAX SPEED (sti/min)
4	TW1-898L14D2T5	3500
8	TW2-898L14D2T5	2800

7

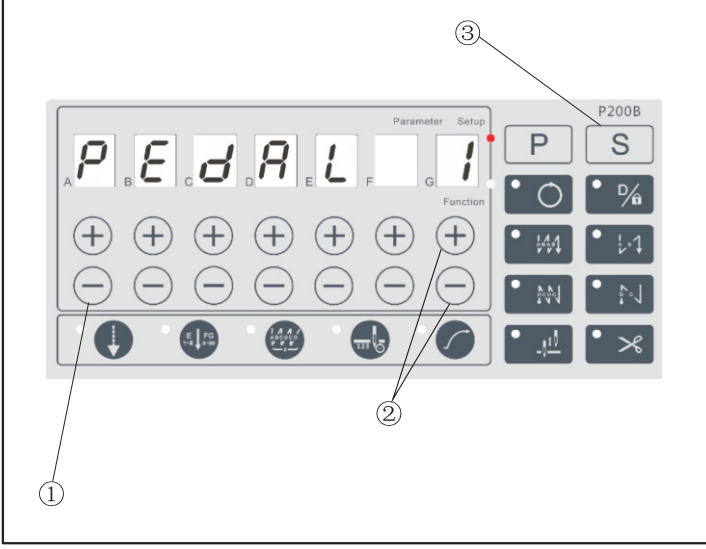

8. Changeover between normal pedal and standing pedal Fig 7

- 1.Press the key "-" ① and power on
- 2.Adjust the keys "+/-" ② to number "1", then press key "S" ③ to save
- 3.Restart the system

NOTE:
 "0" normal pedal
 "1" standing pedal

9. Adjusting the start position Fig 8

NOTE:

1. After trimming, if the mark ③ over deviate from the mark ④, please adjust the system start position.

2. Before adjustment, please be sure the machine ID

1. Press the key "O" ① and power on

2. Turn the handwheel, the degree will be displayed on the panel

3. Make sure the thread take up lever is at its highest position, this is start position

4. Press the key "S" ② and the panel will display zero, then restart the system.

8

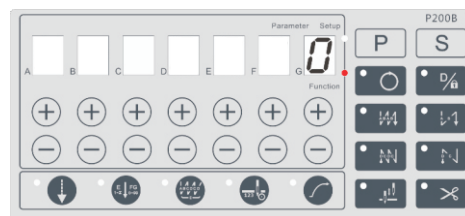
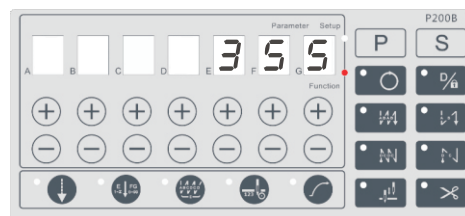
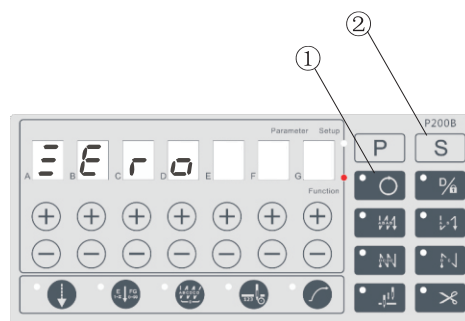
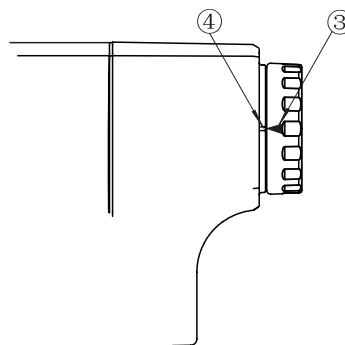

10. Installing pneumatic mechanisms(fig.9)

1. Fix pneumatic parts ① under table④ with screw ②
2. Connect the air tubes ③ as shown in fig

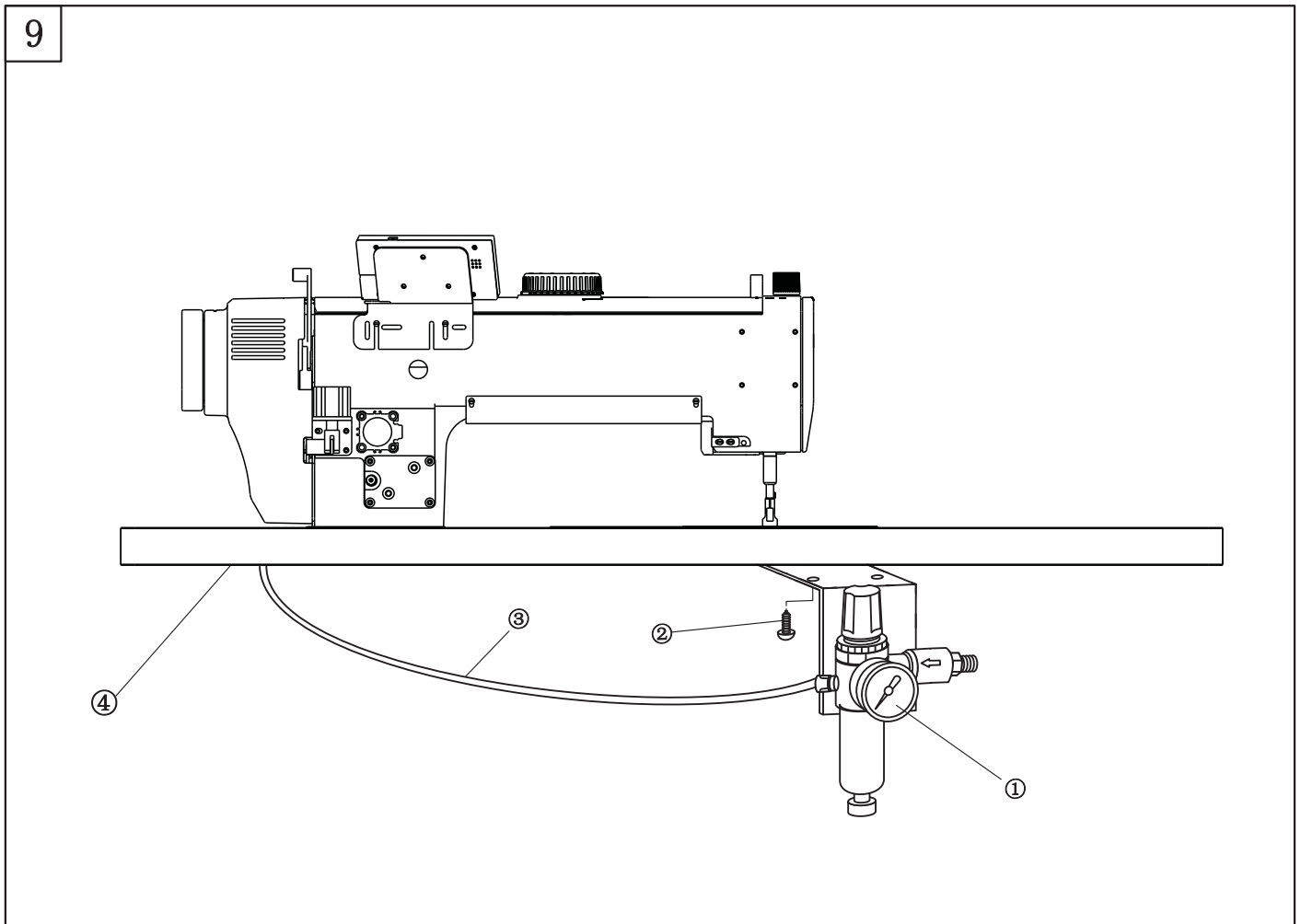

11. Adjusting pneumatic pressure(fig.10)

Pneumatic pressure of the compressed air should be set to 0.45Mpa before use.

1. Pull up nut ② on Assy ① to adjust the pressure
2. Restore nut ② after adjustment.

Note: Close or open ③ to release compressed air.

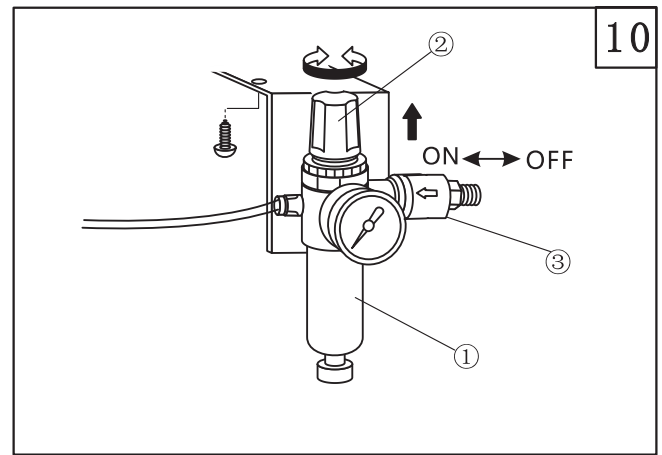

12. Installing the thread stand(fig.11)

Assemble the thread stand as shown in the illustration, and then install it to the work table.

Note:

1. Securely tighten the nut ① so that the thread stand does not move.
2. When installing the thread stand, raise the spool holder ② to a position where it does not touch the machine head when the machine head is tilted back.

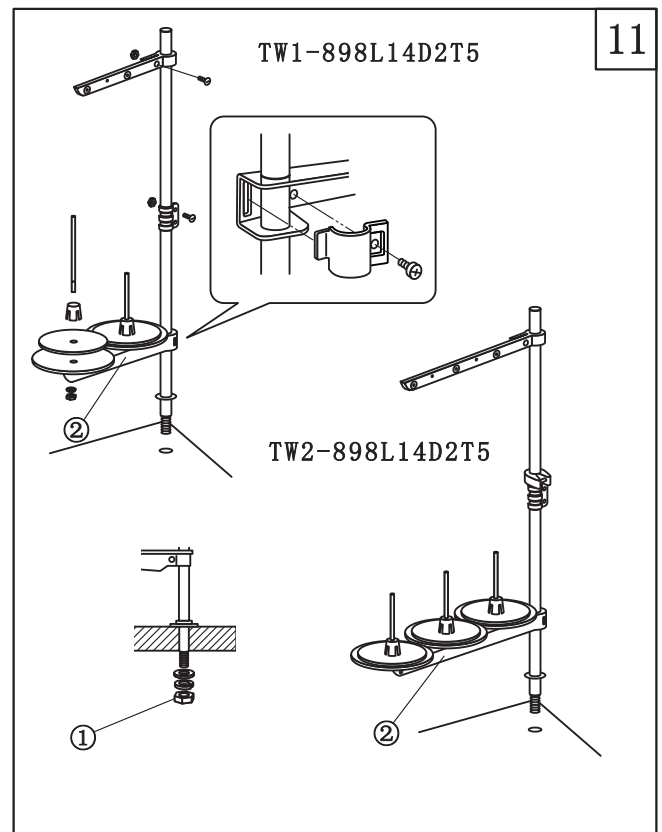

13. Installing the knee lifter(fig.12)

1. Install the knee switch ① under the table with screw ②

Note: Make sure to adjust a comfortable position to the operator.

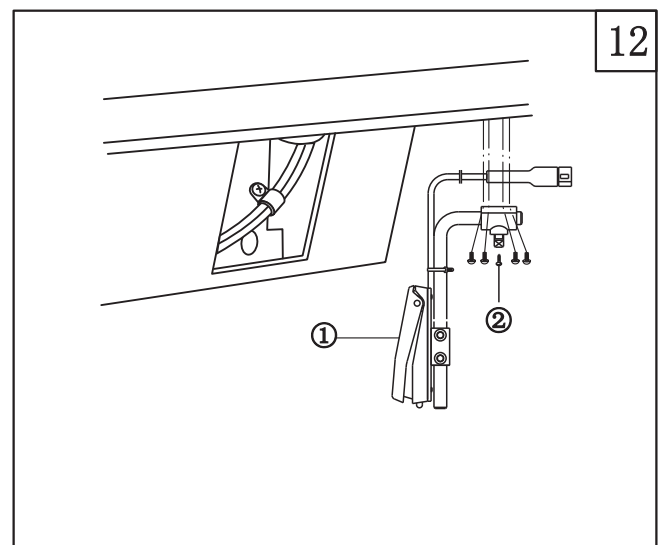

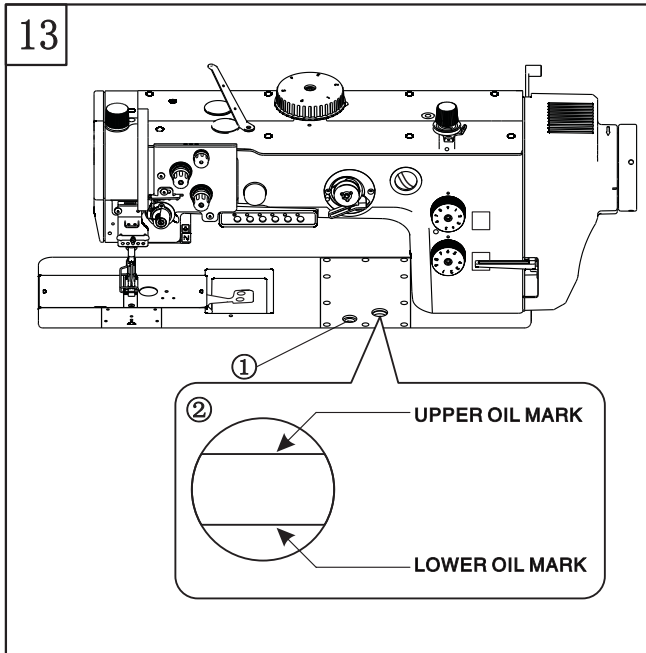

14. Lubrication(fig13, 14)

Lubrication should be made for the initial running or reuse after long periods of idleness.

1. Loosen setscrew ① of the oil tank filler hole.
2. Fill lubricant into the oil tank as per marks ②
3. Fasten screw ③ after oiling.

Note: If the oil in use is down to the lower mark, replenish oil immediately.

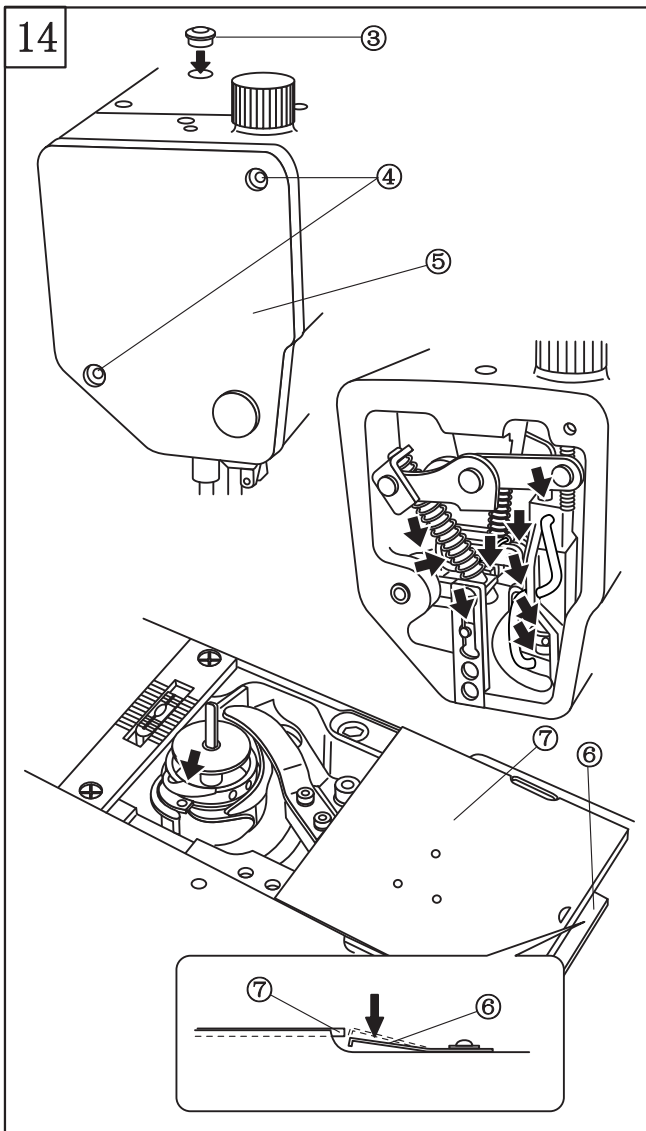

4. Take off rubber cover ③
5. Infuse about 10cc of lubricant into the oil tank
6. Insert the rubber cover
7. Loosen screw ④, remove face plate ⑤. Drip 2 or 3 drops of oil respectively to positions illustrated by arrows.
8. Press down leaf-spring ⑥ and push sliding plate ⑦ sideways. Drip oil to position shown by arrows

15. Rotating direction of pulley(fig.15)

1. Insert the power plug and switch on the machine.
2. Step the foot pedal slightly to confirm the pulley rotates clockwise illustrated by arrow ①.
3. Step the foot pedal slightly to confirm the oil goes up in the oil window.

Note: Oil will arrive at positions need lubrication after running for 1 minute.

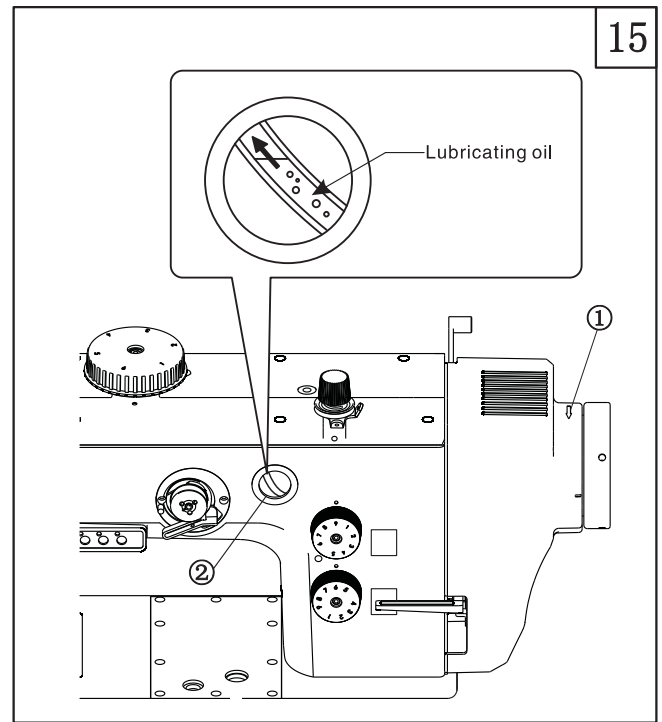

16. Installing the needle(fig.16)

1. Turn the pulley to rise the needle bar ① to it's highest point.
2. Loosen screw ②.
3. Insert the needle fully into the needle bar, making sure that the long groove is facing leftward. Tighten screw ② Securely.

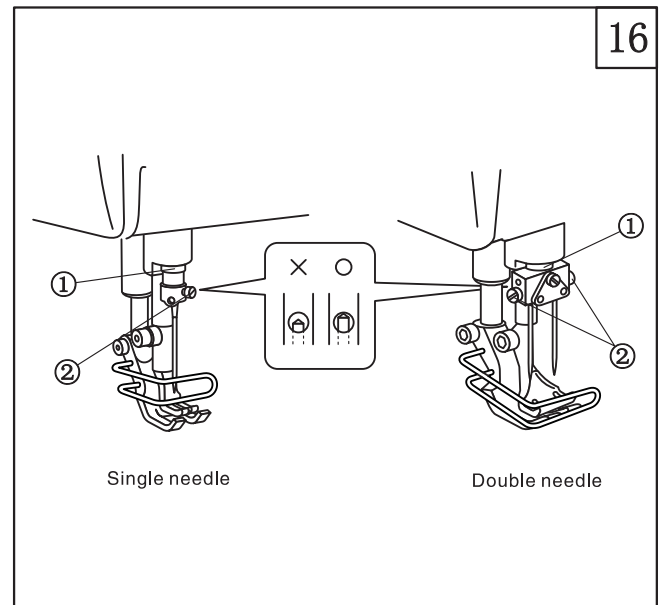

17. Removing the bobbin(fig.17)

1. Press down the leaf spring ① and push sliding plate ② sideways.
2. Pull up the latch ③ of the rotary hook, and then remove the bobbin ④.

Notice: Anti-racing spring ⑤ prevents the bobbin from racing during sewing or thread trimming.

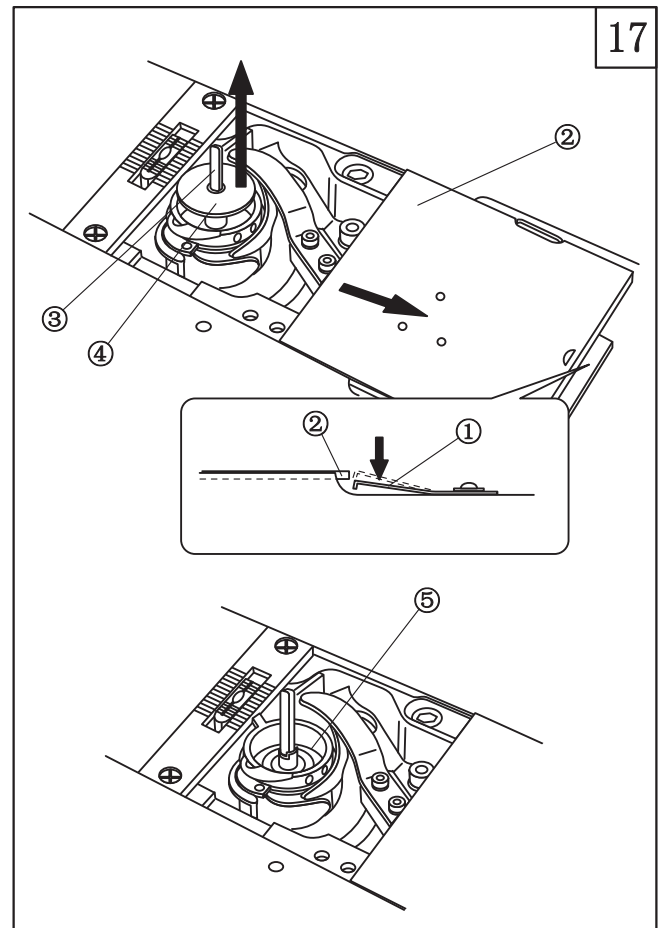

18. Winding the bobbin thread(fig.18)

1. Insert bobbin ① onto the bobbin winder shaft ②
2. Push the bobbin presser ③ toward the bobbin
3. Step the pedal to start winding
4. Bobbin presser ③ will return automatically when winding is completed
5. Remove bobbin ① and cut the thread with knife after winding. And press the thread under the knife to start next winding operation

Note:

1) Thread amount wound should be a maximum of 90% to the bobbin capacity, which can be adjusted by loosening screw ④ and moving bobbin presser ③ sideways.

2) If the thread is wound unevenly, loosen the tension nut ⑤ to adjust

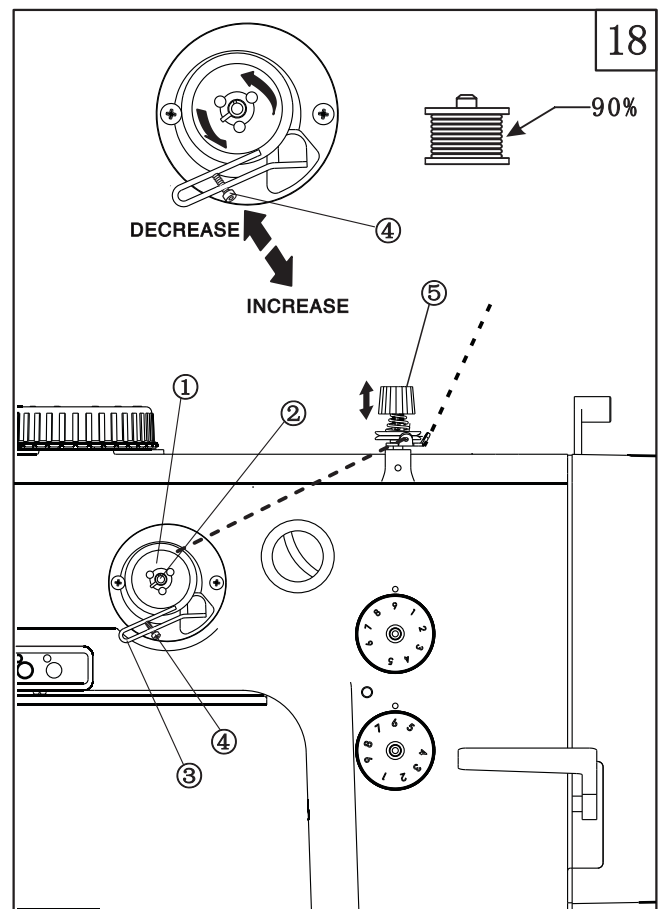

19

19. Installing the bobbin(fig.19)

Place the bobbin ① onto the rotary hook ② so that the thread winding direction is as shown in the illustration. Turn the pulley to rotate the outer rotary hook ④ until the tension spring ③ can be seen.

Pass the lower thread thru the groove A in the inner rotary hook, pull it around between the opener and the projection B on the inner rotary hook, and then pass it along the inside of the tension spring ③.

Pull the lower thread out from the back of the groove C and then lower latch ⑥

Pull the lower thread to check that it comes out smoothly from the hole D and that the bobbin ① turns in the direction of the arrow.

Pull the lower thread until there is a length of about 50 mm above the needle plate ⑦.

Close slide plate ⑧, but leave a gap which is just enough for the thread to pass through.

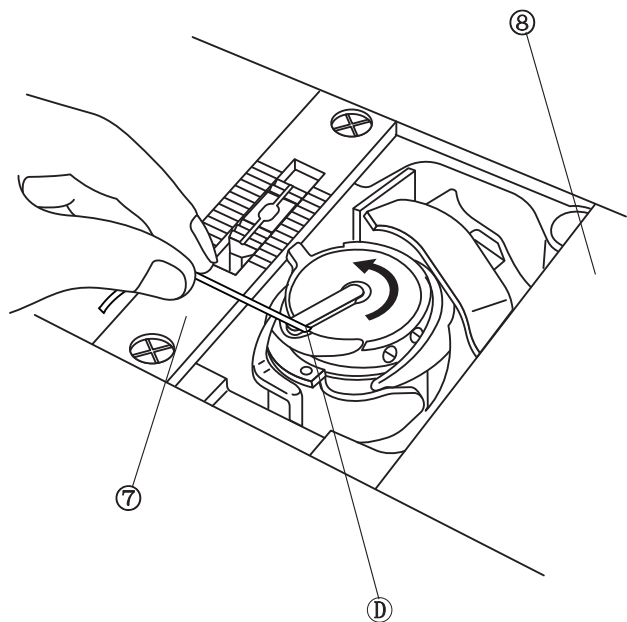
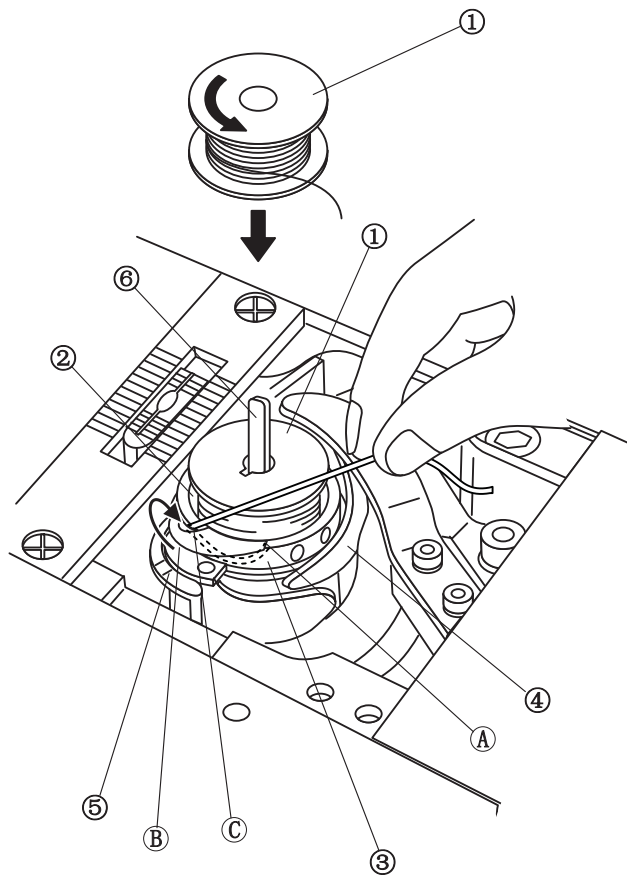

20. Threading the upper thread(fig.20)

Raise the thread take-up lever before threading press the electric handwheel ①, then threading the needle thread

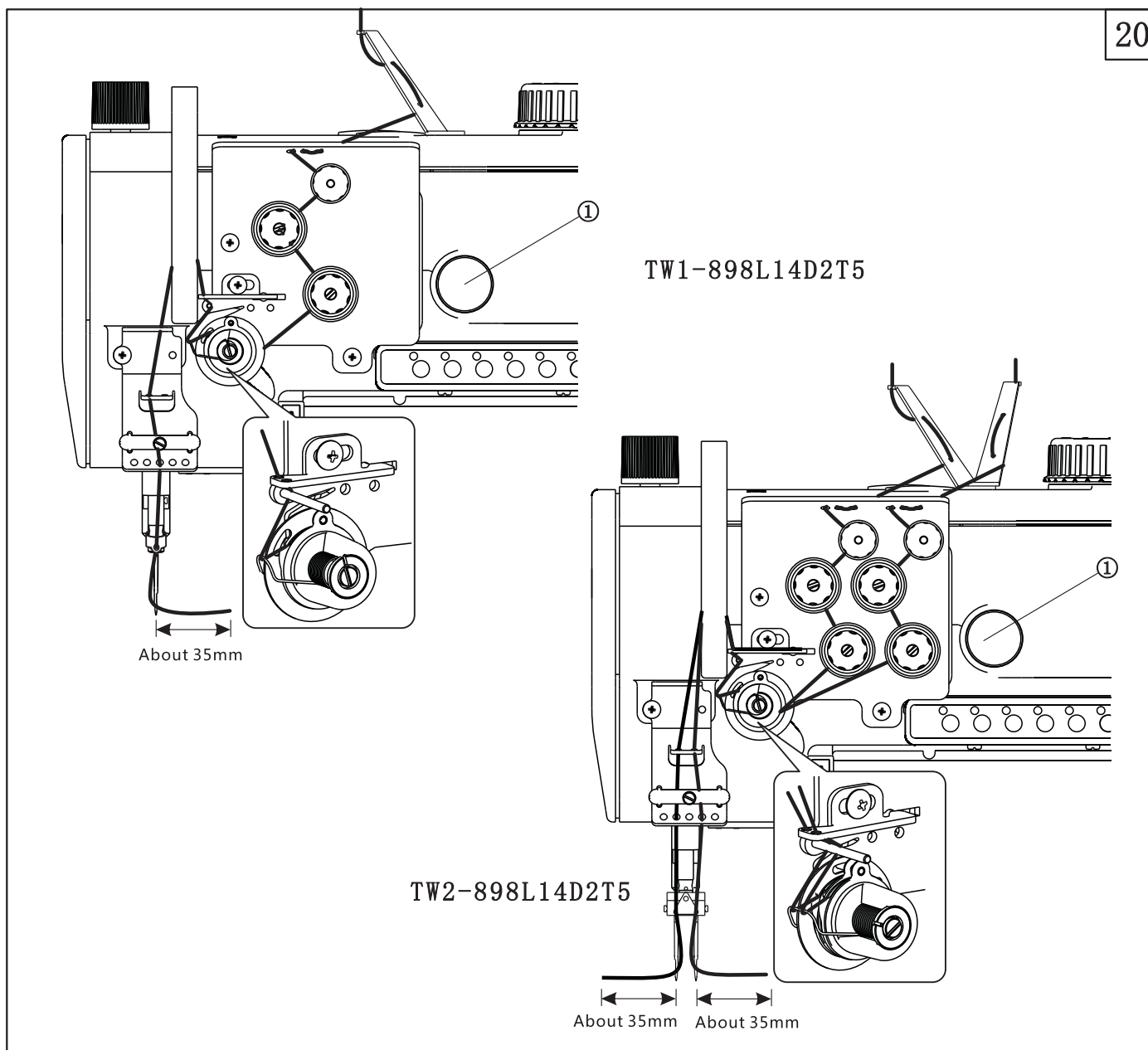

21. Adjusting the stitch length(fig.21, 22)

1.Fig. 21

Turn the feed adjustment dial ① clockwise or counter clockwise to align the number with the mark ②. The greater the number is, the longer the stitch length get.

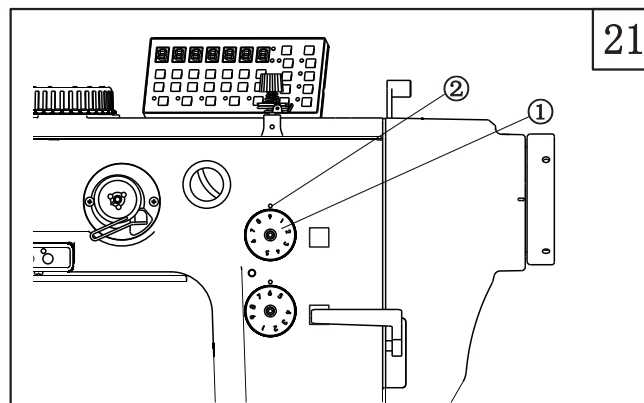

22

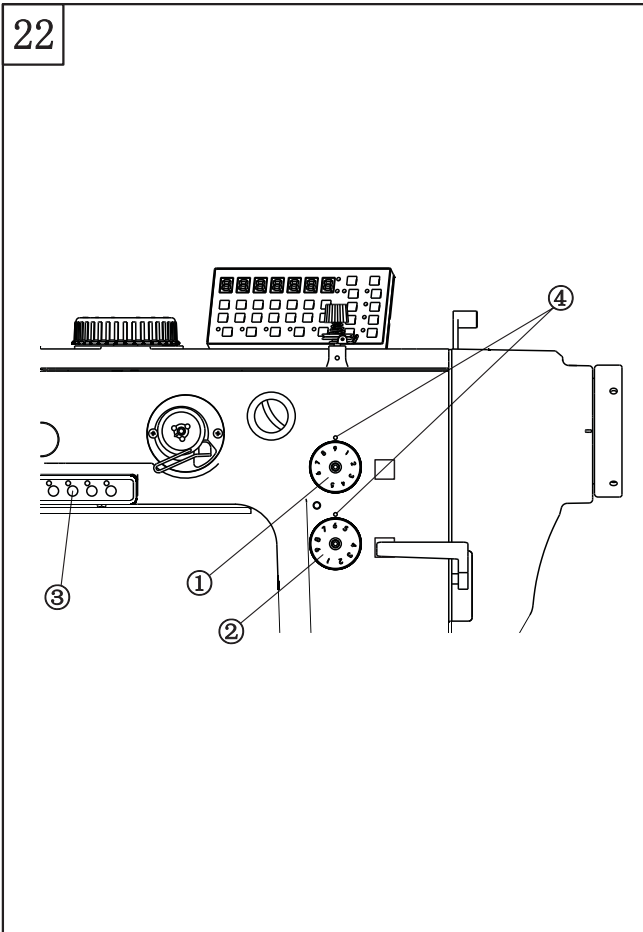

2. Fig.22

The feed adjustment dial ① and ② can be used to set 2 different stitch lengths, which can be switched between each other by pressing the stitch length change switch ③ during sewing.

Set the stitch lengths by turning the feed adjustment dials ① and ② clockwise or counterclockwise to align the numbers with the marks ④.

CAUTION: Forcibly turning the dial may cause damage of the sewing machine. Set the upper dial to a higher number than the lower dial.

▲ Adjusting the normal stitch length (when using only one type of stitch length)

Adjust dial ① only.

Note: Dial ② is not used at this time, so set it to the smallest number. Also check that the indicator for the stitch length change switch ③ is turned off.

▲ Setting 2 different stitch lengths

1) Use dial ① to set the longer stitch length

2) Use dial ② to set the shorter stitch length.

Notice: It's not possible to use dial ① to set the shorter stitch and dial ② to set the longer stitch.

3) Press switch ③ to switch between 2 different stitches during sewing.

23

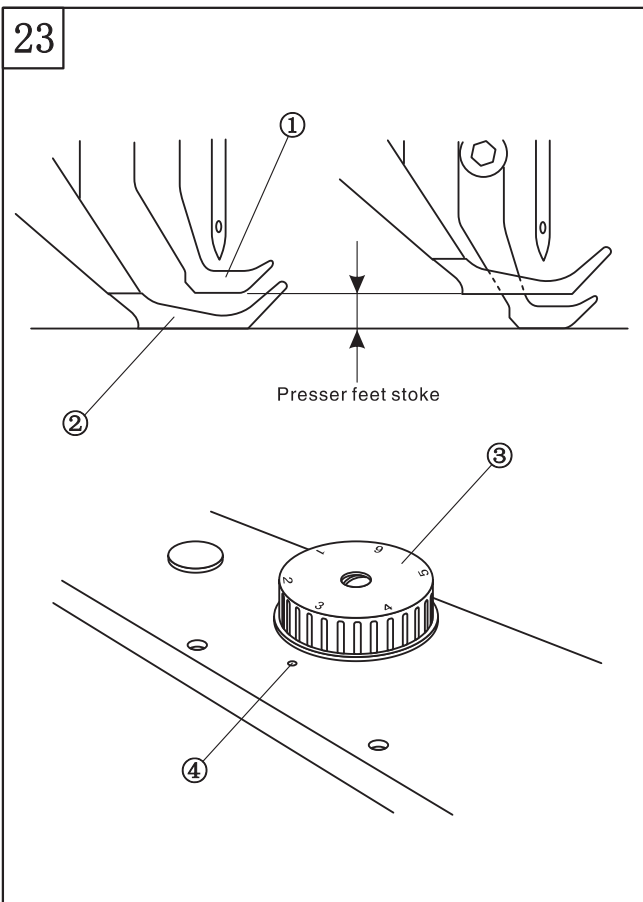

22. Alternating presser foot movement amount (fig.23, 24)

1. Fig 23

The alternating movement amount for the inner presser foot ① and the outer presser foot ② can be adjusted within the range of 1–7mm using the alternating presser foot movement dial ③.

Turn the dial ② clockwise or counterclockwise to align the number (mm) with the mark ④.

2. Fig.24

Using the alternating presser foot movement change switch ⑤. This switch can be used to change between 2 types of alternating movement: the movement amount set by the alternating presser foot movement dial ③ and the maximum movement amount (7mm).

OFF – The alternating presser foot movement amount equals the amount set by the dial ③.

ON – The alternating presser foot movement amount equals the maximum movement amount (7mm).

Note: The alternating presser movement amount can also be switched by knee switch

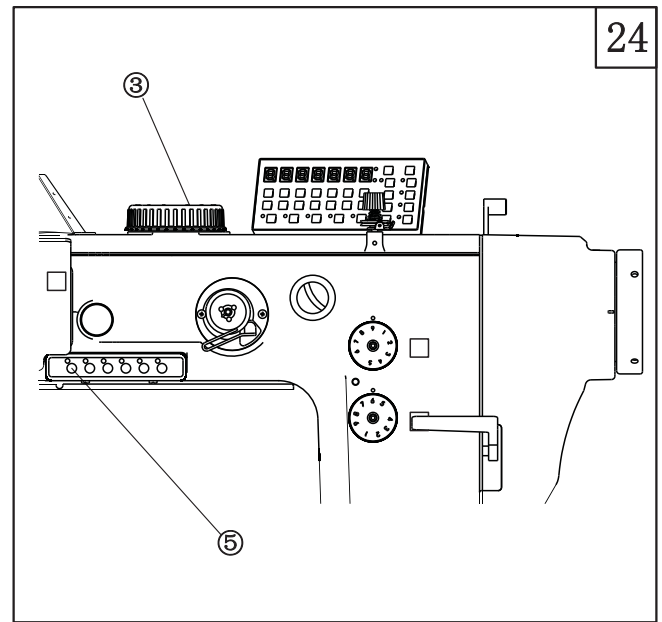

23. Using the manual switches(fig.25)

① Quick reverse switch

Backtacking is carried out when this switch ① is pressed

② Sewing light switch

③ Alternating presser foot movement change switch
Machine can be switched between 2 different alternating presser foot movement amounts each time ② is pressed

◆ If the indicator is off, the alternating presser foot movement amount equals that set by dial ⑥

◆ If the indicator is on, the alternating presser foot movement amount equals the maximum amount (7mm).

④ Auto bartack select switch

If this switch ④ is pressed when either start backtacking or end backtacking has been set to ON at the operation panel, backtacking is canceled for the first time only.

Furthermore, if this switch ④ is pressed when neither start nor end backtacking has been set, backtacking is carried out for the first time only.

⑤ Half stitch switch

If this switch is pressed while the sewing machine has been stopped during sewing, the needle can then be moved up and down. (it will not move after thread trimming has been carried out.)

⑥ Stitch length change switch

Stitch length changes alternately between 2 different stitch lengths set each time switch ⑥ is pressed.

◆ OFF – sewing with the stitch length set by dial (11)(longer stitch length).

◆ ON – sewing with the stitch length set by dial (12)(shorter stitch length).

⑦ Second tension release switch

When cross stitch, turn on the switch, then the second tension (13) active

⑧ Safety switch

Press the key, the machine will stop for safety

⑨ Electric handwheel

Total two modes optional

1. Press the handwheel, the machine will be in safety and threading mode, and thread tension (13)(14) release.

2. Turn the handwheel, machine will turn slowly.

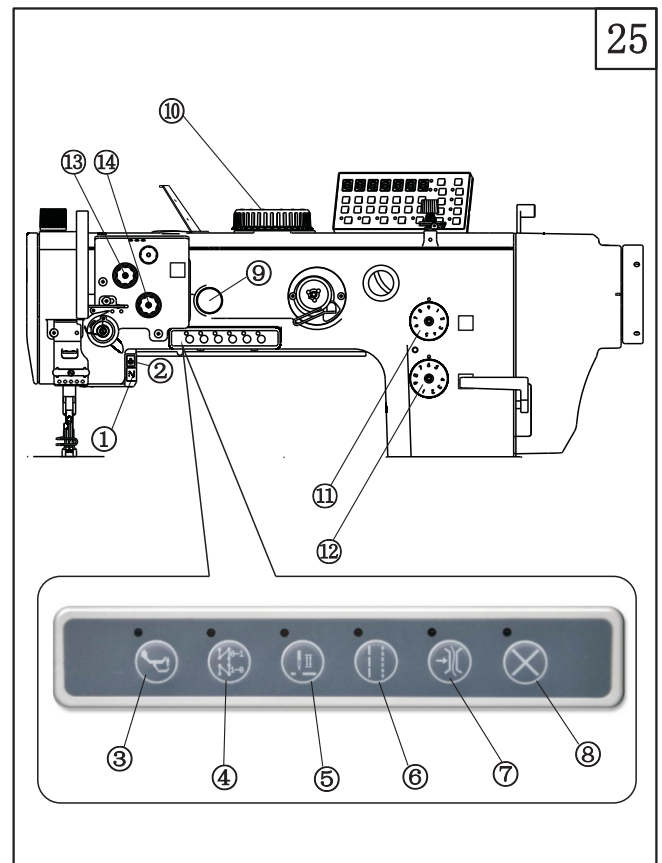

26

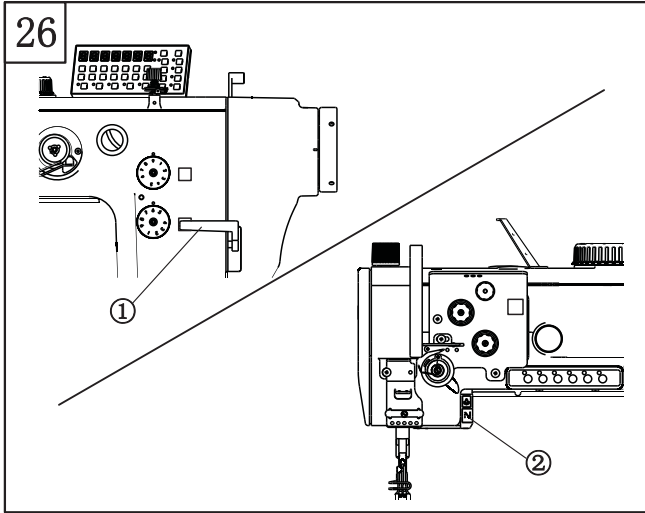

24. Backtacking (fig.26)

When the reverse lever ① or the quick reverse switch ② is pressed during sewing, the feed direction will be reversed. When it is released, the feed direction will return to normal.

27

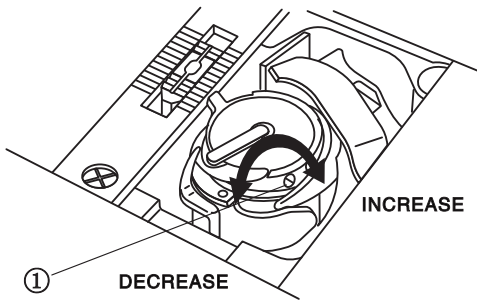
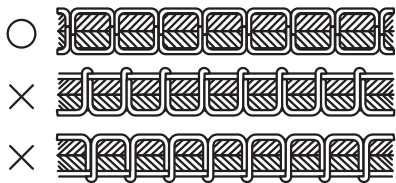

25. Thread tension(fig.27)

1. Lower thread tension
Turn the adjustment screw ① to adjust the lower thread tension.

2. Upper thread tension
After the lower thread tension has been adjusted, adjusted the upper thread tension so that a good, even stitch is obtained.

- 1) Lower the presser foot.
- 2) Adjust by turning the thread tension nuts ②

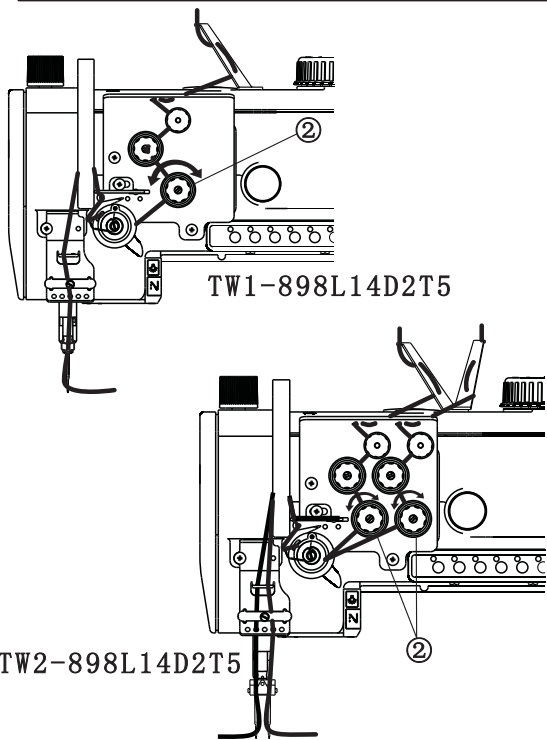

26. Adjusting the presser foot pressure(fig.28)

1. If the presser adjusting dial ① is turned clockwise, the presser foot pressure will become stronger, and if it is turned counterclockwise, the pressure will become weaker.
2. The presser foot pressure should be as weak as possible, but strong enough so that the material does not slip.

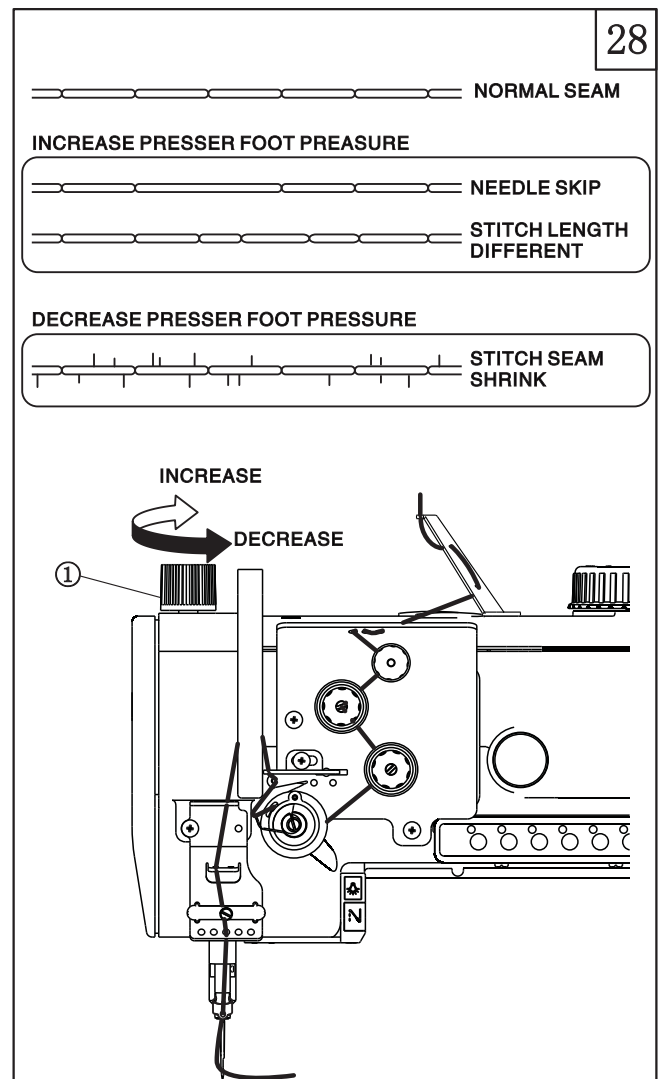

27. Adjusting the trailing length after thread trimming (fig.29)

Adjust by turning the pretension ①.

1. At the time of thread trimming, the thread tension is loosened and tension is applied by the pretension ① only.
2. The standard trailing length for the upper thread is 20–35 mm.
3. If the tension of the pretension ① is increased, the lengths of the threads trailing from the needle tips will be reduced. If the tension is reduced, the lengths will be increased.

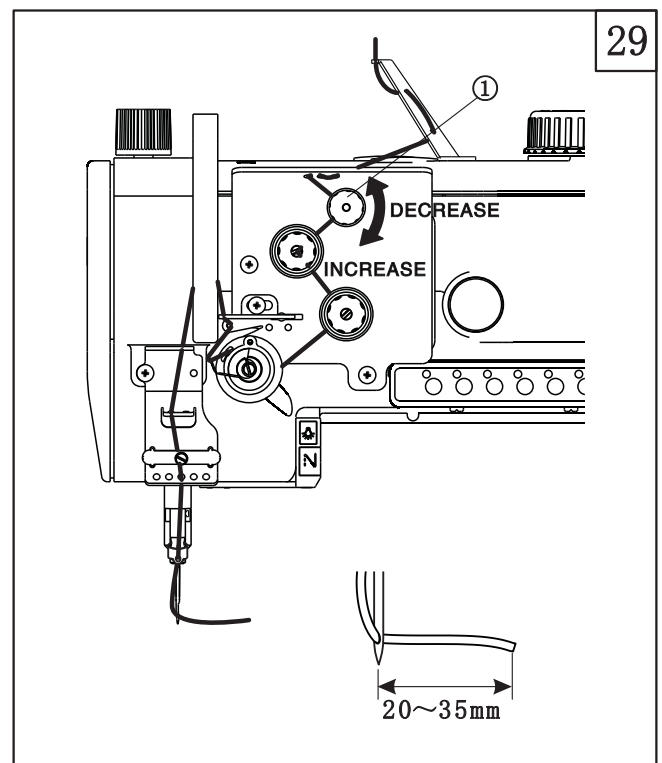

30

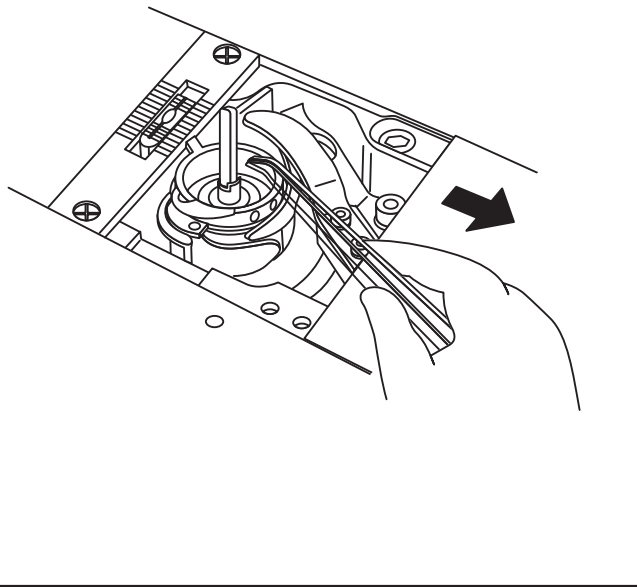

28. Clearing(fig.30)

1. Open slide plate, and remove the bobbin.
2. Remove any thread scraps from inside the rotary hook.
3. Install the bobbin, close the slide plate

31

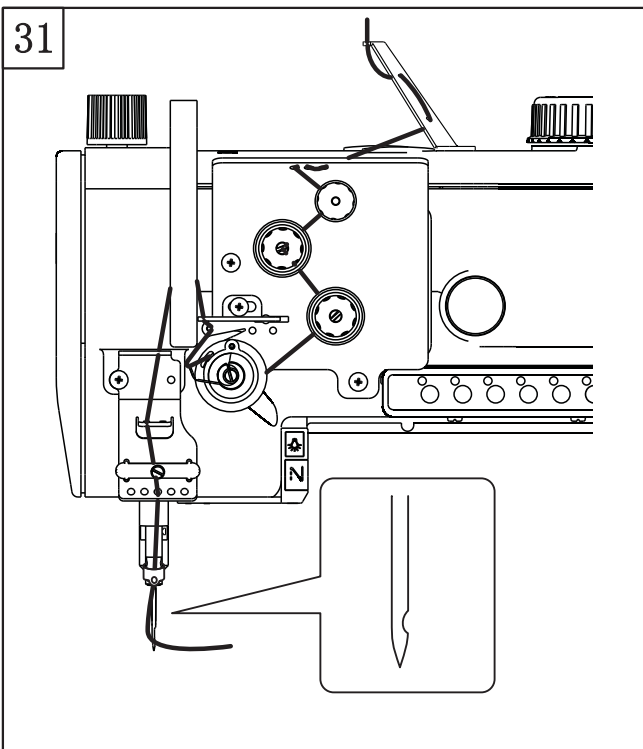

29. Checking(fig.31)

1. Check that the upper threads have been threaded correctly.
2. Check that the end of the needle is not worn out or broken.
3. Carry out a test sewing.

30. Draining water from the air system (fig.32)

If water has collected in the bottle ①, close the cock ② and loosen the knob ③ by turning it in the direction of the arrow to drain the water as per illustration in fig.32.

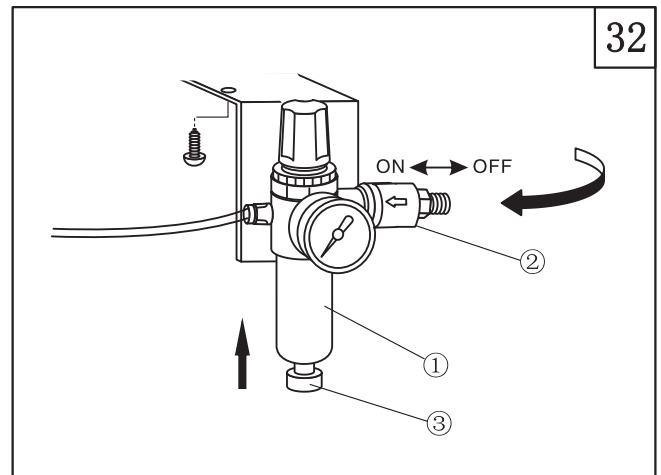

31. Cleaning the oil filter(fig.33)

If the filter ① is dirty, or if the amount of oil consumption increases dramatically, remove 2 screws ② and 2 screws ③, and then remove the filter ①. Clean or replace the filter ① as required. Fasten screws after cleaning.

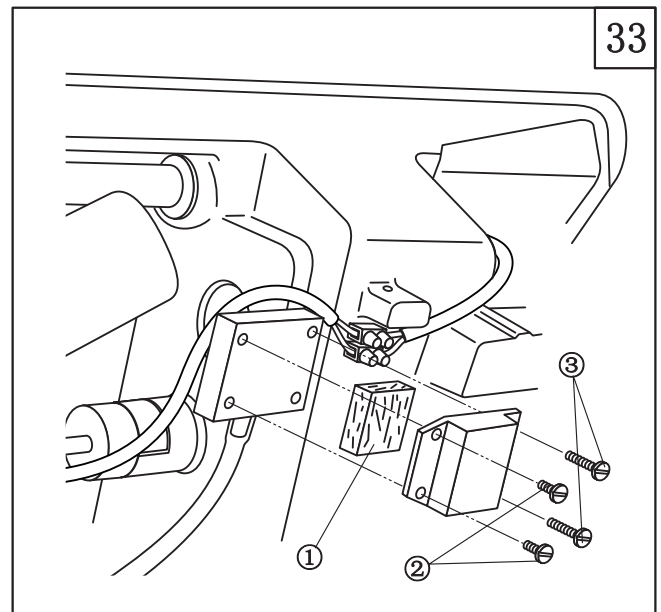

32. Adjusting the thread tension spring(fig.34)

1. Thread tension spring position

The standard operation range for the thread tension spring ① is 5–10 mm.

- Loosen the screw ② and then turn the stopper ③ to adjust the operating range.
- Tighten the screw ②

2. Thread tension spring tension

The standard tension for the thread tension spring ① is 0.4–0.8N.

- Loosen the nut ④
- Loosen the screw ⑤, and then turn the tension adjusting stud ⑥ to adjust the tension.
- Tighten the screw ⑤, and then tighten the nut ④.

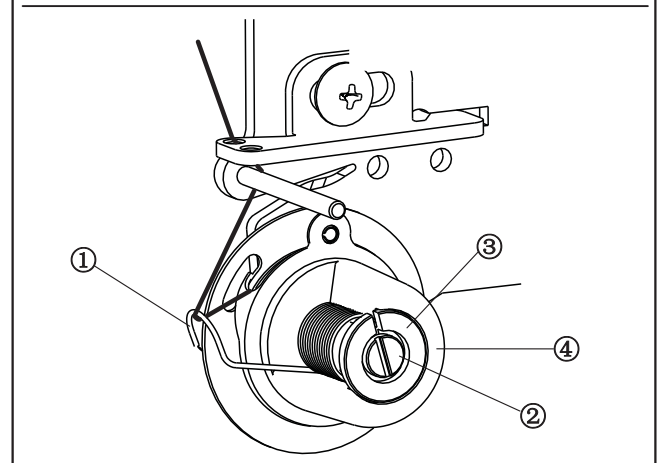
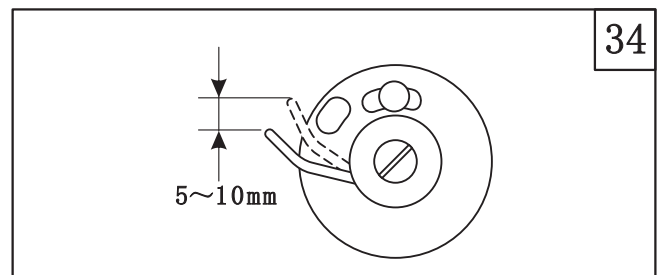

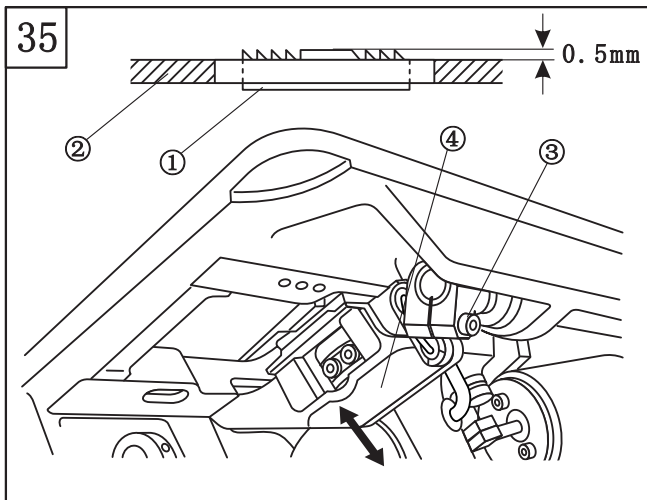

33. Adjusting the feed dog height(fig.35)

The standard height when the feed dog ① is at its highest point above the needle plate ② is 0.5 mm.

1. Turn the machine handwheel to set the feed dog ① to its highest point.
2. Loosen the bolt ③, and then move the feed bracket ④ up or down to adjust the height of the feed dog ①.
3. Tighten the bolt ③.

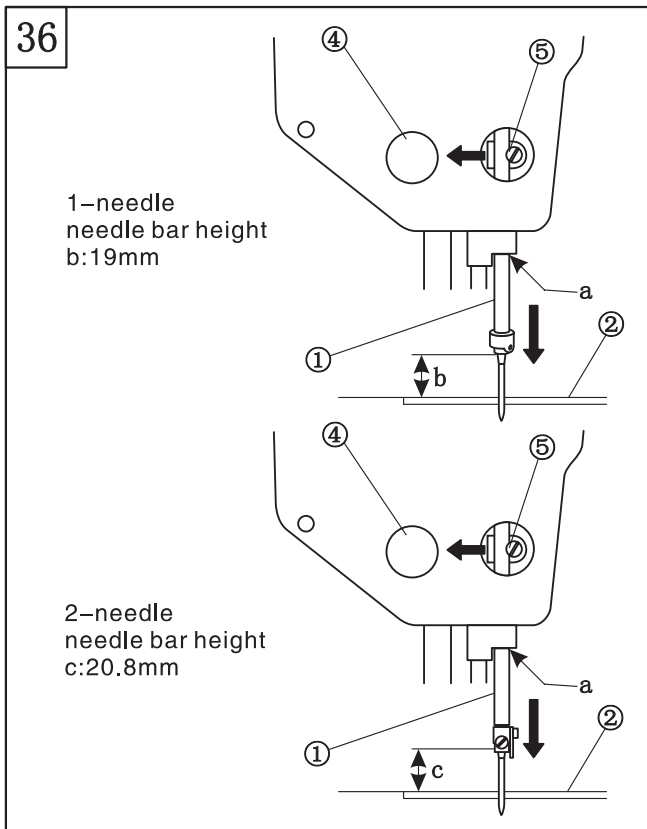

34. Adjusting the needle bar height(fig.36)

Set the feed adjustment dials to the minimum settings. The distance from the setting surface of the needle plate ② when the needle bar ① is at its lowest position is:

- 1-needle-19 mm.
- 2-needle - 20.8 mm

1. Remove the rubber cap ③
2. Set the feed adjustment dials to the minimum settings
3. Turn the pulley to set the needle bar ① to its lowest position.
4. Loosen the screw ⑤, and then move the needle bar ① up or down to adjust the height of the needle bar ① above the setting surface of the needle plate ②.
5. Securely tighten the screw ⑤

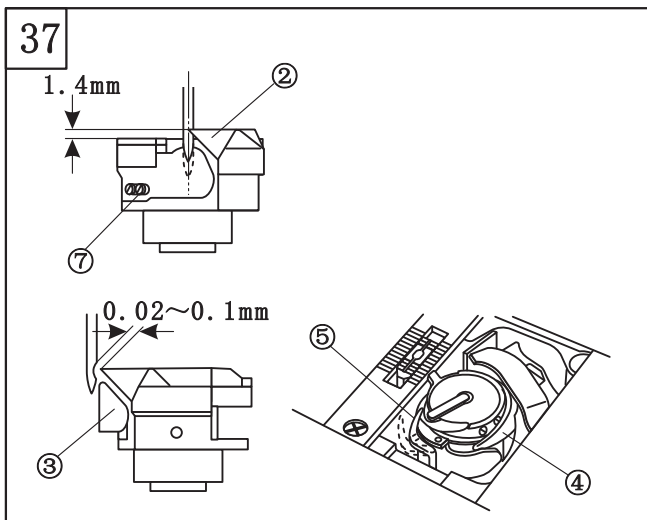

35. Needle and rotary hook timing(fig.37, 38)

1. Set the feed adjustment dials:

- 1-Needle: Min
- 2-Needle: 6

2. Turn the pulley to raise the needle bar from its lowest position to the point where "G" is visible in the slot of belt cover ①. The rotary hook tip ② should be aligned with the center of the needle at this time.

Furthermore, the clearance between the needle and the rotary hook tip ② should be 0.02 ~ 0.1 mm when the needle guard ③ is not touching the needle.

Note: Be sure to adjust the clearance between the needle and the rotary hook tip after adjusting the needle and rotary hook timing.

The rotary hook ④ rotates twice for each single rotation of the pulley. Consequently, the rotary hook ④ will rotate twice during a single stroke of the opener ⑤.

3. Remove the needle plate.
4. Lay down the machine head.
5. Loosen the bolt ⑥.
6. Turn the machine pulley to raise the needle bar from its lowest position to the point where "G" is visible in the slot of belt cover ①. (The needle will rise 2 mm, and the distance from the needle hole to the rotary hook tip ② will be 1.4mm.)
7. Turn the rotary hook ④ to align the rotary hook tip ② with the center of the needle, and then securely tighten the bolt ⑥.

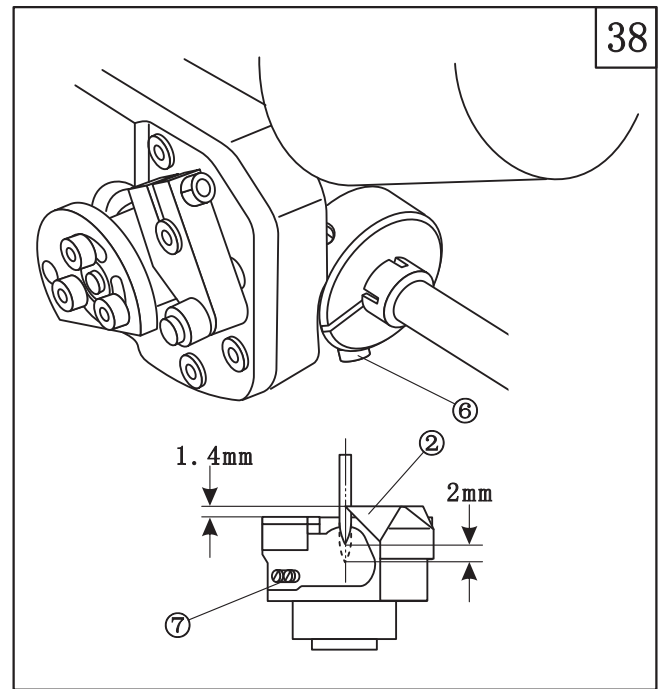

36. Adjusting clearance between needle and rotary hook tip(fig.39)

1. Turn the bolt (right) ① clockwise so that the needle guard is away from the needle.
2. Loosen the bolts ② and ③.
3. Turn the horizontal hook base collar ④ clockwise so that side A of the horizontal hook base ⑤ gently touches the bed worked surface B. In this condition, move the horizontal hook base to the left or right to adjust so that the clearance between the needle and the rotary hook tip becomes 0.02 ~ 0.1 mm.
4. Tighten the bolt ③
5. Tighten the bolt ②
6. Install the needle plate ⑥. At this time, insert the stopper ⑦ of the inner rotary hook into the notch in the needle plate ⑥.
7. Adjust the position of the needle guard ⑧.

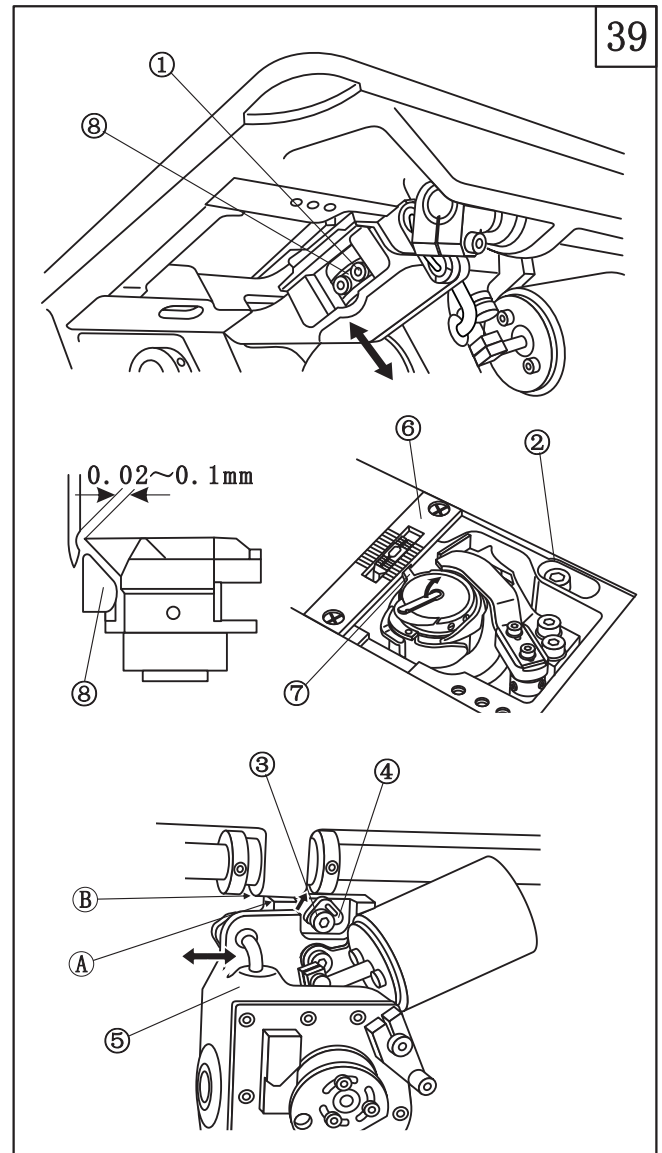

40

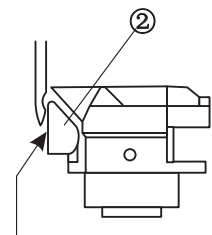

Clearance 0.1~0.2mm

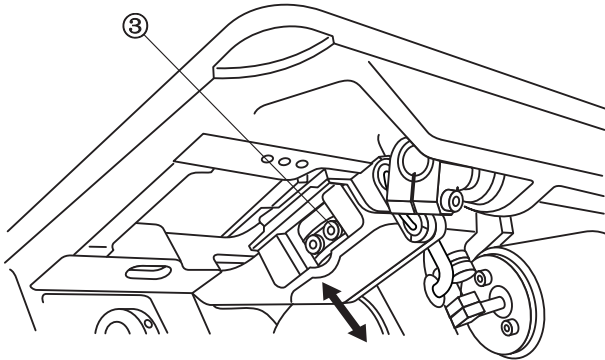

37. Adjusting the needle guard position (fig.40)

Turn the pulley to raise the needle bar from its lowest position to the point where "G" is visible in the slot of the belt cover ①. The needle guard ② should touch the needle by 0.1 ~ 0.2mm at this time.

1. First carry out the "Needle and rotary hook timing" and "Clearance between needle and rotary hook tip" adjustments.
 2. Lay down machine head.
 3. Turn the bolt (right) ③ to adjust so that there is a clearance of 0.1 ~ 0.2mm between needle and the needle guard ②.
- Note: If the bolt (right) ③ is turned clockwise, the needle guard ② will move away from the needle, and if it is turned counterclockwise, the needle guard ② will move toward the needle

41

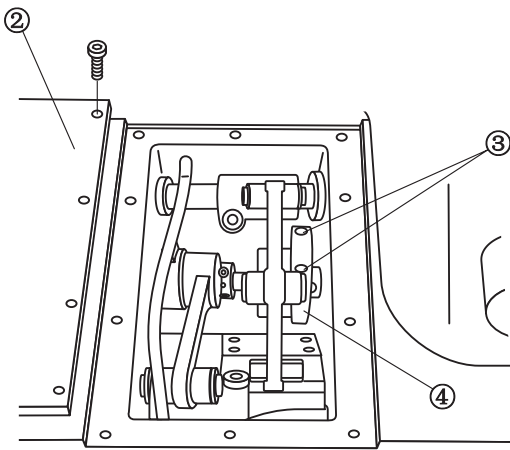
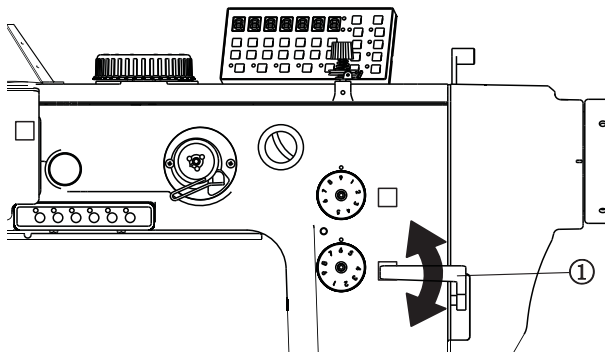

38. Adjusting the needle and feed mechanism timing (fig.41, 42)

1. Horizontal feed direction

Set the feed adjustment dials to the maximum. Then turn the machine pulley until "B" is visible in the belt cover slot. Then adjust so that the needle and the feed dog do not move even when the reverse lever ① is moved up and down at this time.

- a. Remove the bed upper cover ②.
- b. Set the feed adjustment dial to the maximum settings.
- c. Loosen the two set screws ③.
- d. Turn the machine pulley until "B" is visible in the belt cover slot.
- e. Turn the lower feed cam until the set screw ④ nearest to you is provisionally facing straight up.
- f. Turn the lower feed cam ④ gradually until it is at the position where the needle and the feed dog do not move even when the reverse lever ① is moved up and down.
- g. Tighten the two set screws ③.

2. Vertical feed direction

Set the feed adjustment dials to the minimum. Then adjust as follows so that the feed dog ① is at its highest position (0.5 mm above the top of the needle plate ②) when the needle bar is at its lowest position.

- Loosen the two set screws ③.
- Turn the machine pulley to set the needle bar to its lowest position.
- Turn feed cam ④ to align the point ⑤ of feed cam ④ with the center line of feed rod ⑥.
- Tighten the set screws ③.

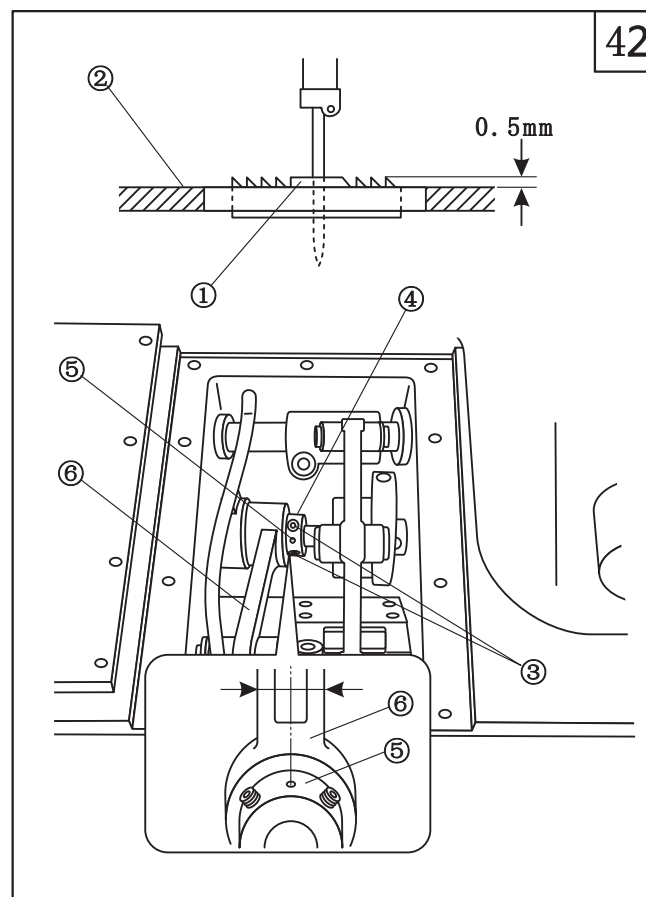

39. Adjusting the opener (fig.43, 44)

1. Opener position

Adjust so that the clearance between the needle plate ③ and the stopper ④ of the inner rotary hook ② is 0.5 ~ 0.7mm (for thread to go thru) when the opener ① is at its closest position to the inner rotary hook ②.

- Turn the machine pulley to move the opener ① in direction "a" (opening direction), and then loosen the set screw ⑤.
- Turn the machine pulley to move the opener ① in direction "b" (closing direction), and then loosen the set screw ⑥.
- Turn the machine pulley to move the opener ① as close to the inner rotary hook ② as possible.
- While pressing the opener ① against the inner rotary hook ② with your finger, adjust so that the clearance between the needle plate ③ and the stopper ④ of the inner rotary hook ② is 0.5 ~ 0.7 mm.
- Tighten the set screw ⑤.
- Turn the machine pulley to move the opener ① in direction "a" (opening direction), and then tighten the set screw ⑤.

Note: The distance from the tip of the opener ① to the inside of the bed is approximately 13.4 mm when the opener ① is moved as far as it will go in direction "a" (opening direction).

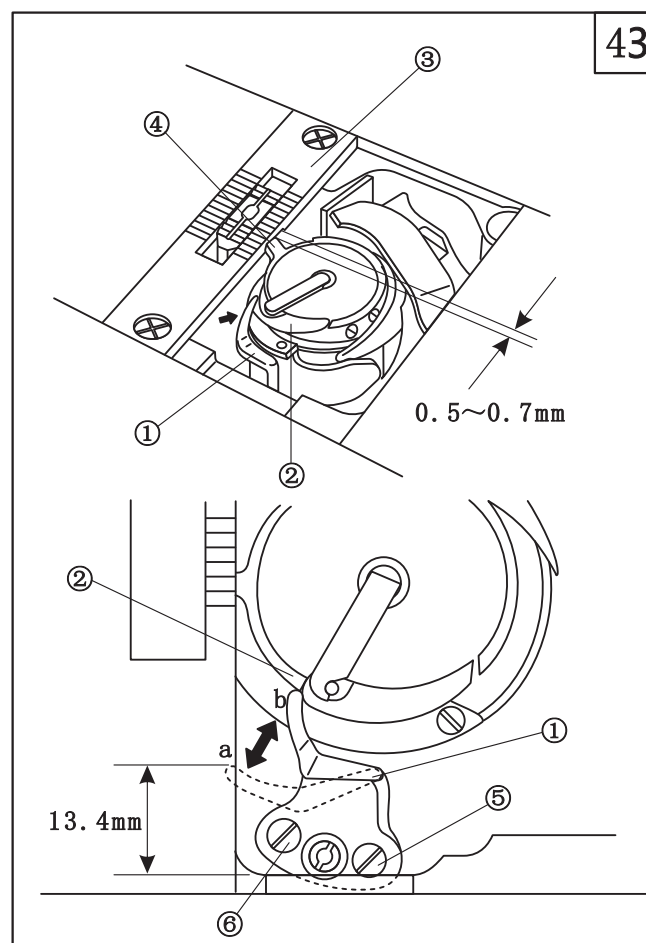

2. Opener and rotary hook timing
Adjust so that the angle of rotary hook tip ⑦ is as follows when opener ① is at its closest position to the inner rotary hook ②.

The angle : $75^{\circ} \sim 90^{\circ}$

- a. Loosen set screws ⑧.
- b. Turn the machine pulley, adjust the angle of rotary hook.
- c. Turn opener shaft ⑨, set opener ① at its closest position to the inner rotary hook.
- d. Tighten screws ⑧.

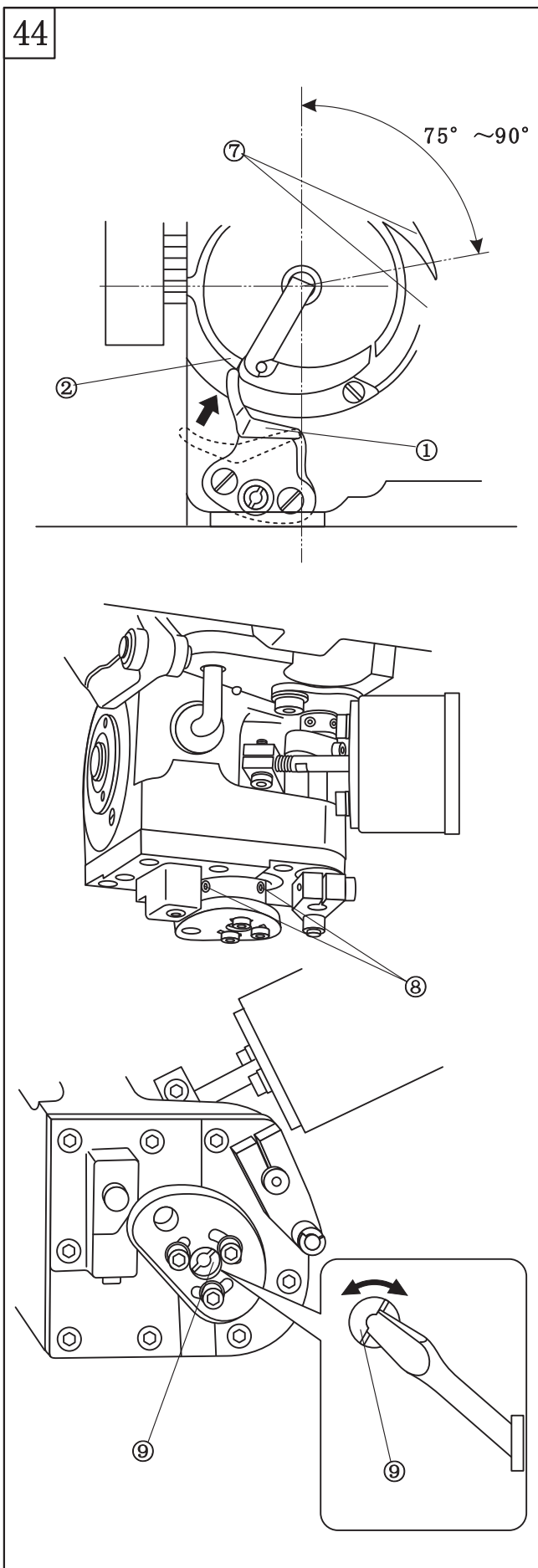

40. Adjusting the presser foot height(fig.45)

The standard height of the outer presser foot ② is 9 mm when it is raised by the presser lifter bar ①.

1. Remove the motor guards.
2. Loosen the screw ④, adjust the clearance between presser bar lifting bar ① and cam ③, tighten the screw
3. Release the bar ①, make the presser foot upward or downward to adjust the clearance to 9mm
4. Install the motor guard

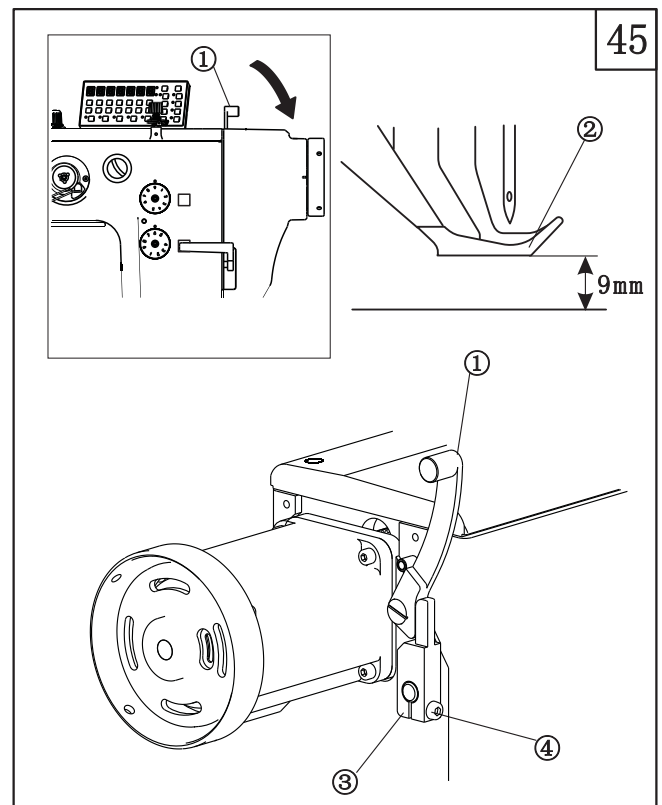

41. Adjusting the alternating presser foot movement amount(fig.46, 47, 48)

1. Maximum alternating presser foot movement amount

Carry out the following adjustment to set the maximum alternating movement amounts for the inner presser foot ① and outer presser foot ② to the maximum of 7mm.

- a. Remove the upper plate.
- b. Lift up adjusting bracket ③ so that adjusting bracket collar ⑤ touches the stopper support plate ④.
- c. Loosen the bolt ⑧ and turn connecting lever ⑨ to adjust so that the distance from the outer edge of the screw ⑥ to the outer edge of pin ⑦ is 45.5 mm at this time. Then tighten the bolt ⑧.

When installing the upper plate, set the alternating presser foot movement dial to the "1" Position.

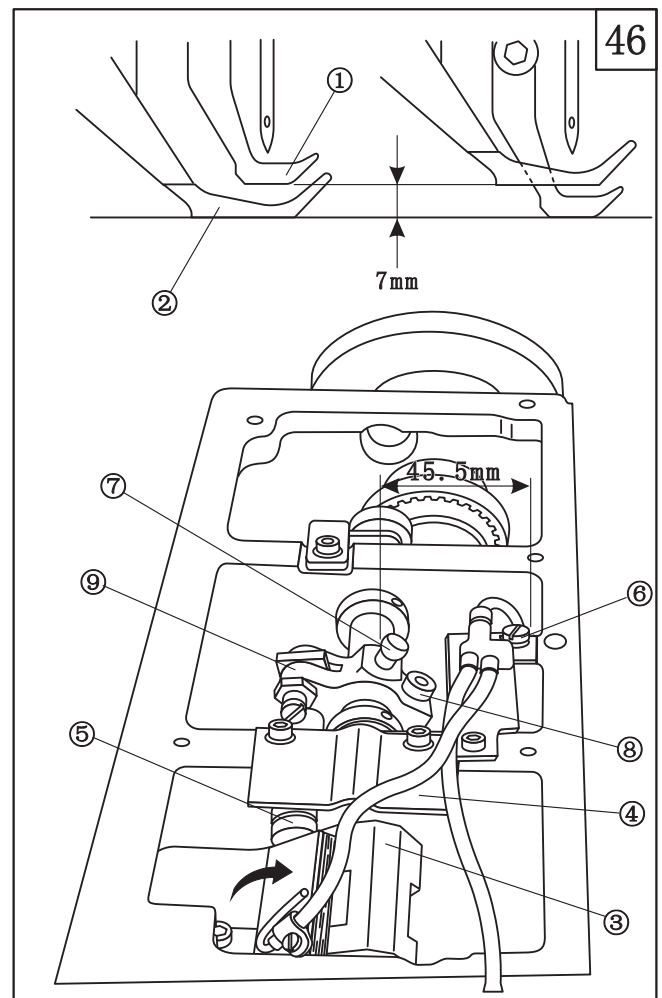

2. Inner presser foot and outer presser foot movement amounts

Carry out the following adjustment to make the movement amounts for the inner presser foot ① and the outer presser foot ② equal when the presser feet are lowered and the machine pulley is turned.

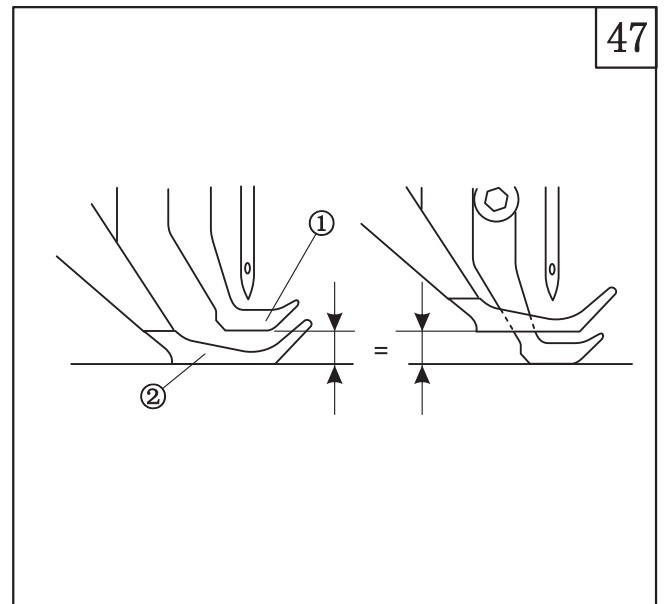

3. Adjustment

- First, carry out the "feed dog height", "needle bar height" and "needle and feed mechanism timing" adjustment.
- Set the feed adjustment dials to the maximum.
- Remove the rubber cap ③.
- Turn the alternating presser foot movement dial ④ to the "3" position.
- Loosen the screw ⑤.
- Turn the machine pulley toward you to align the tip of the needle and the top of the feed dog ⑦ with the top of the needle plate ⑥.
- Move the connecting lever ⑧ to adjust so that both the inner presser foot ① and outer presser foot ② are in contact with the top of the needle plate ⑥ at this time. Then tighten the screw ⑤.

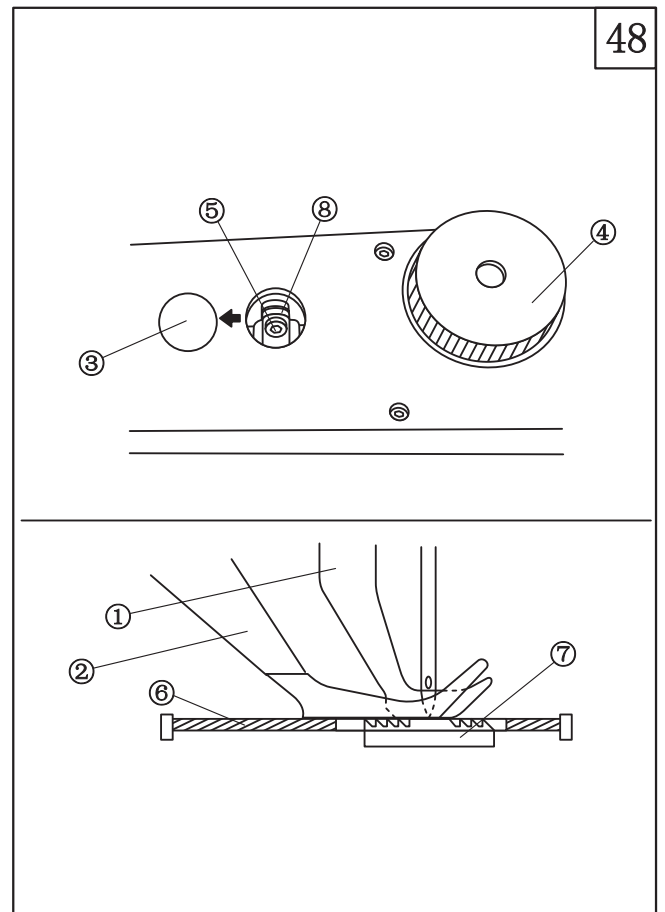

42. Adjusting the presser foot timing(fig.49)

When the presser feet are lowered and the machine pulley is turned toward you, the inner presser foot should touch the feed dog before the needle arrives at the feed dog. Then when the needle lifts up, the tip of the needle should move away from the feed dog before the inner presser foot moves away.

1. Remove the upper cover.
2. Loosen the two screws ①.
3. Turn the machine pulley until "C" is visible in the slot of the belt cover ② (highest take-up lever position).
4. Turn inner presser cam UD ③ to adjust so that the point ④ of inner presser cam UD ③ is facing straight up.
5. Tighten the screws ①.

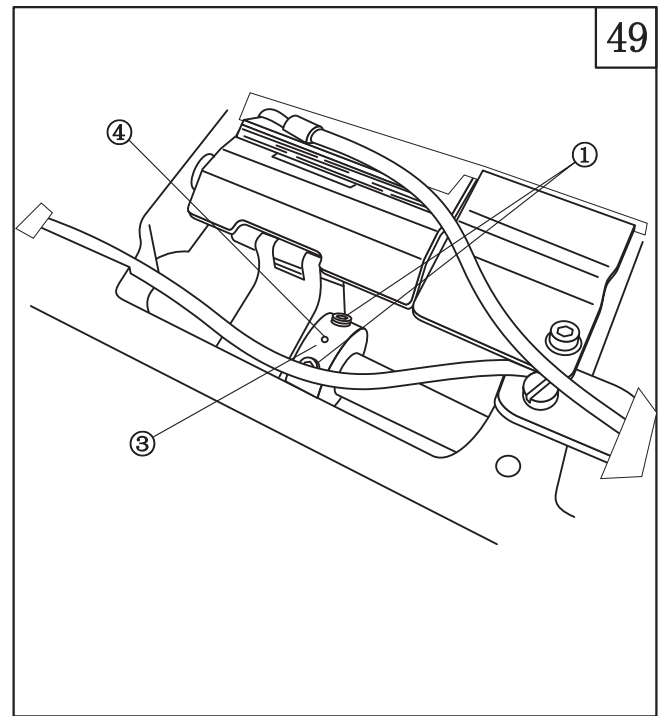

43. Adjusting the fixed knife position(fig.50)

The distance from the groove of slide plate to the fixed knife should be 26 mm. Furthermore, the distance from the edge of the needle plate to the left edge of the tip of the fixed knife should be 4 mm.

1. Loosen the two bolts ②.
2. Adjusting the position of the fixed knife ①, and then tighten the bolts ②.

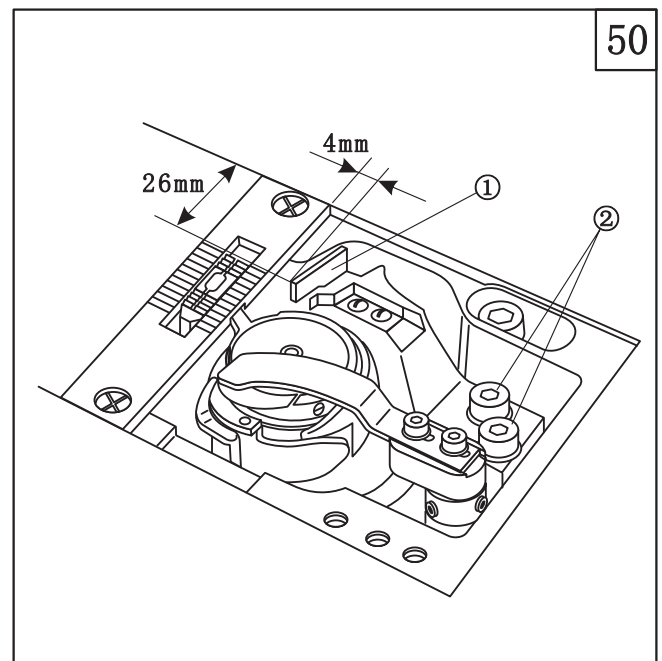

51

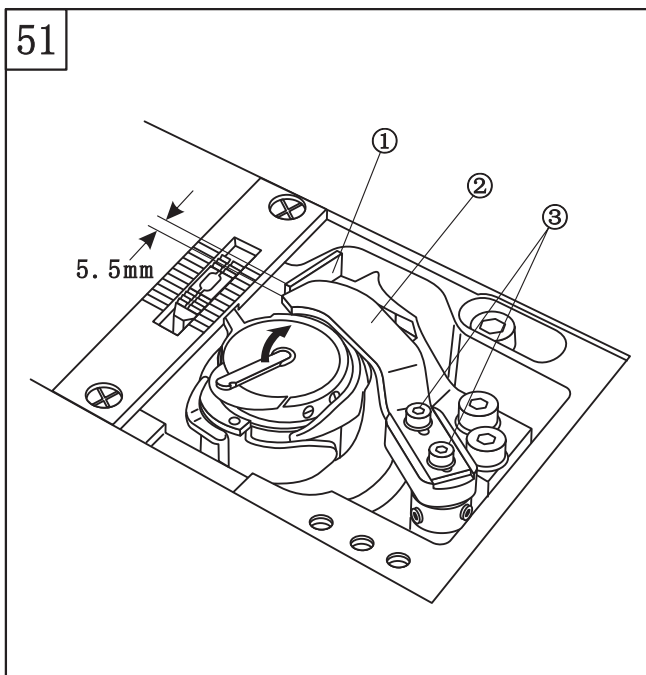

44. Adjusting the knife timing position(fig.51)

After adjusting the position of the fixed knife ①, adjust the knife timing position. Adjust so that the driving knife ② starts touching the fixed knife ① at a position 5.5 mm along the front edge of the driving knife ②.

1. Turn the machine pulley until "D" is visible in the belt cover slot. (This is to set the driving knife ② so that it can then be moved by hand)
2. Loosen the two bolts ③
3. Move the driving knife ② to the left or right to adjust its position, and then tighten the bolts ③.

52

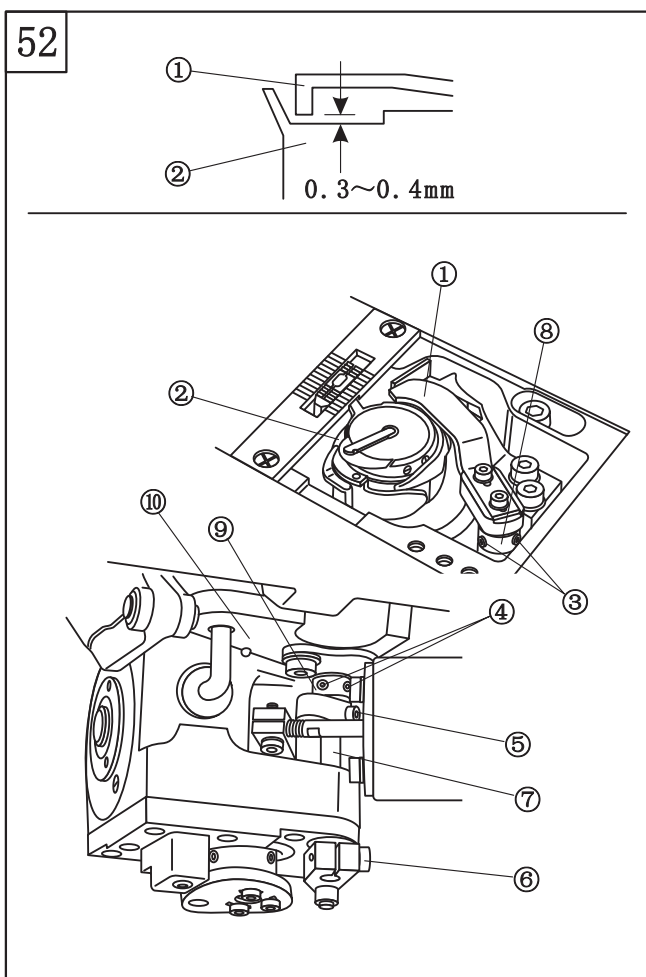

45. Height of the driving knife(fig.52, 53)

The clearance between the lower blade edge of the driving knife ① and the lower surface of the inner rotary hook ② should be 0.3 ~ 0.4 mm.

1. Turn the machine pulley until "D" is visible in the belt cover slot. (This is to set the driving knife ① so that it can then be moved by hand.)
2. Loosen the 2 set screws ③.
3. Tilt back the machine head.
4. Loosen the 2 set screws ④, the bolt ⑤ and ⑥.
5. Move the driving knife shaft ⑦ up or down to adjust the position of the driving knife ①.
6. Clamp the horizontal hook base ⑩ with the set screw collars ⑧ and ⑨, and then tighten the set screws ③ and ④ to secure the driving knife shaft ⑦.

Note: Check that the driving knife shaft ⑦ turns smoothly at this time with no vertical play.
7. Provisionally tighten the bolt ⑤ and ⑥.

2-needle machine

Adjustment for left driving knife is same as the right driving knife.

1. Set screws ④, the bolt ⑤ and ⑥ and their positions are shown in as illustration.
2. 2 set screws ④ should be tighten at the same time.

Note: 1. Set screws should not touch collar ⑨.
2. Position of notch A should be as illustration.

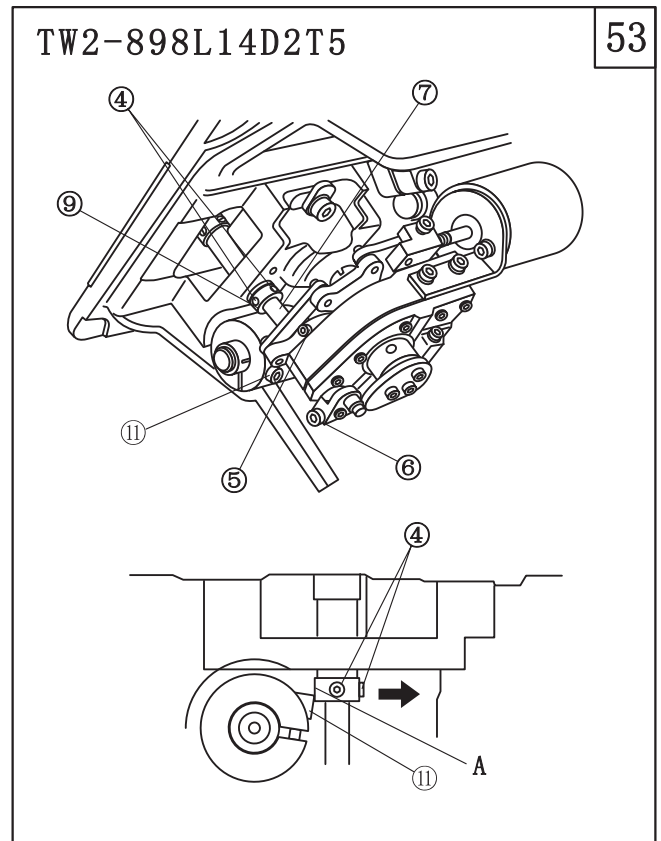

46. Stop position of the driving knife(fig.54)

The distance from the blade of the fixed knife ② to the end of the driving knife ① should be 0.5 mm when the driving knife has moved as far as possible toward the fixed knife ②.

1. Tilt back the machine head.
2. Turn the machine pulley to move the roller ④ of the driving knife arm ③ to the outermost side (right side) of the thread trimmer cam ⑤.
3. Loosen the bolt ⑥.
4. Move the driving knife ① so that the distance between the blade of the fixed knife ② to the end of the driving knife ① is 0.5 mm, and then tighten the bolt ⑥.

Note: Tighten the bolt ⑥ so that the driving knife arm ③ is firmly in contact with the horizontal hook base ⑦.

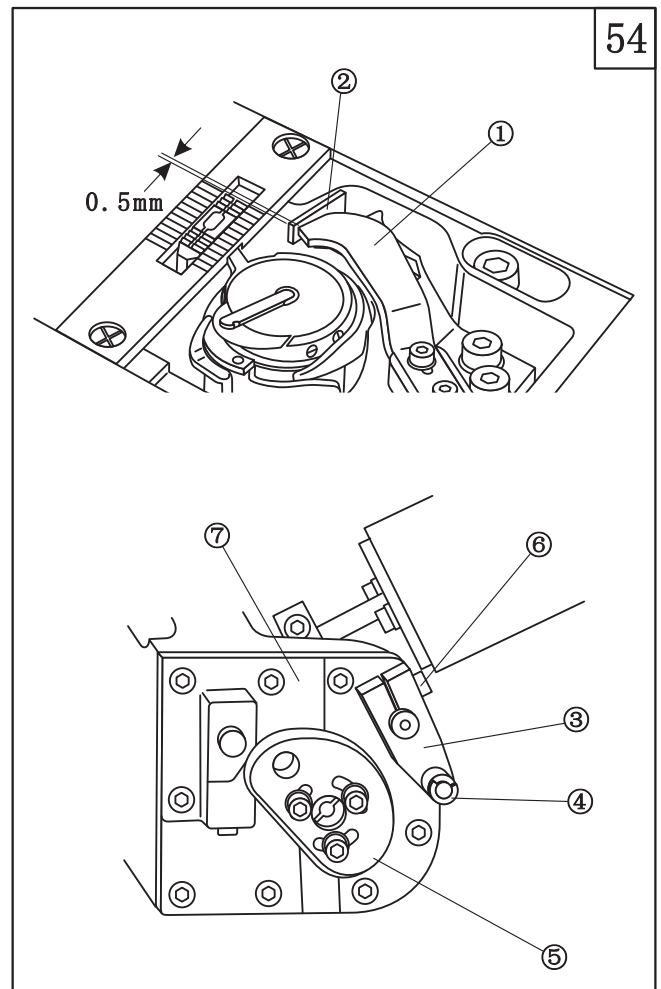

55

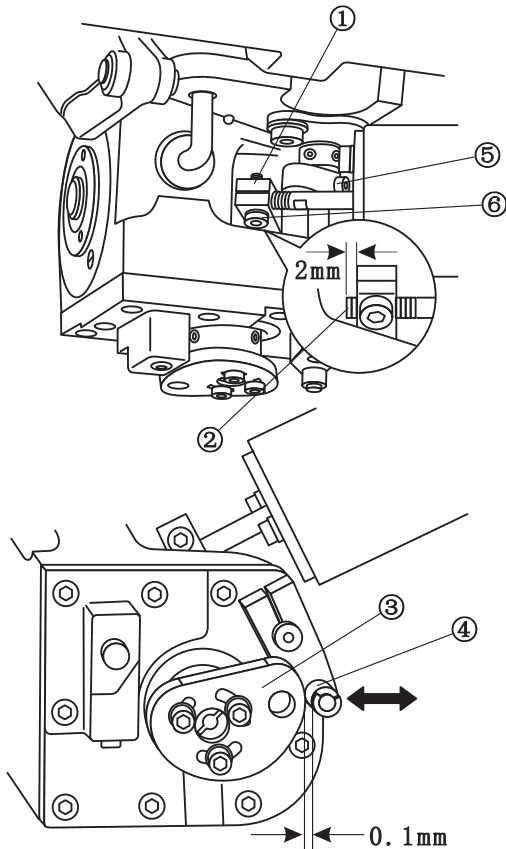

47. Adjusting the driving knife operation position(fig.55, 56)

The standard distance from the left side of driving knife arm ① to the screw tip on the plunger ② of the thread trimming solenoid is 2 mm.

The clearance between the outermost side (right side) of the thread trimmer cam ③ and the roller ④ of the driving knife arm should be 0.1 mm.

1. Tilt back the machine head.
2. Loosen the bolt ⑤.
3. Turn the plunger ② of the thread trimming solenoid so that the distance from the left side of driving knife arm ① to the screw tip on the plunger ② of the thread trimming solenoid is 2 mm, and then tighten the bolt ⑤.
4. Loosen the bolt ⑥.
5. Set the plunger ② to the position where it projects as far as possible to the left.
6. Turn the machine pulley to move the roller ④ of the driving knife arm to the outermost side (right side) of the thread trimmer cam ③.
7. Move the roller ④ so that the clearance between the outermost side (right side) of the thread trimmer cam ③ and the roller ④ is 0.1 mm, and then tighten the bolt ⑥

56 TW2-898L14D2T5

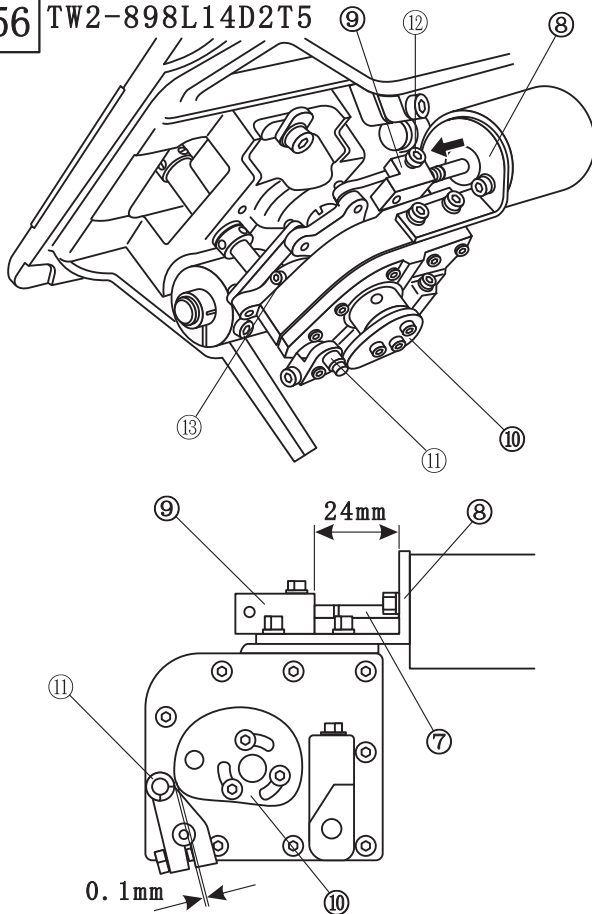

2-needle machine

Adjustment of left driving knife operation position: When adjust nut ⑦ is at its' leftmost side, clearance between setting plate ⑧ and trimming assy ⑨ is 24mm. The clearance between the outermost side (left side) of the thread trimmer cam ⑩ and the roller ⑪ of the driving knife arm should be 0.1 mm.

1. Tilt back the machine head.
2. Loosen the bolt ⑫.
3. Adjust nut ⑦ to the leftmost side.
4. Turn the screw ⑦ so that clearance between setting plate ⑧ and trimming assy ⑨ is 24mm. Tighten screw ⑫
5. Loosen the bolt ⑬.
6. Set the nut ⑦ to the position where it projects as far as possible to the left.
7. Turn the machine pulley to move the roller ⑪ of the driving knife arm to the outermost side (left side) of the thread trimmer cam.
8. Move the roller ⑪ so that the clearance between the outermost side (left side) of the thread trimmer cam ⑩ and the roller ⑪ is 0.1 mm, and then tighten the bolt ⑬ .

48. Adjusting the thread holding spring position (fig.57)

The thread holding spring ① holds the lower thread after trimming to prepare it for the next sewing operation.

1. Loosen the 2 screws ③.
2. Move the thread holding spring ① to adjust its position so that the clearance between the thread holding spring ① and the side of the fixed knife ② should be 1.4 ~ 1.6mm.
3. Tighten the screws ③.

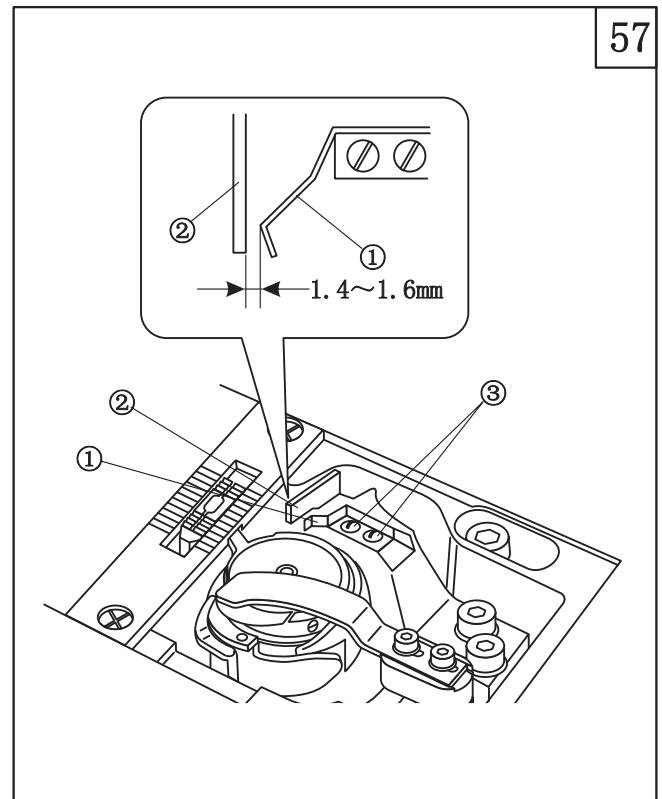

49. Adjusting the thread trimming timing (fig.58)

The center of the pin ①, the center of the reference hole ② and the center of the roller ③ of the driving knife arm should be in a straight line when the machine pulley is turned so that "C" is visible in the belt cover slot.

1. Turn the machine pulley until "C" is visible in the belt cover slot.
2. Tilt back the machine head.
3. Loosen the 3 bolts ④.
4. Turn the thread trimmer cam ⑤ to adjust the position of the thread trimmer cam ⑤ so that the center of the pin ①, the center of the reference hole ② and the center of the roller ③ of the driving knife arm are in a straight line.
5. Tighten the bolts ④.

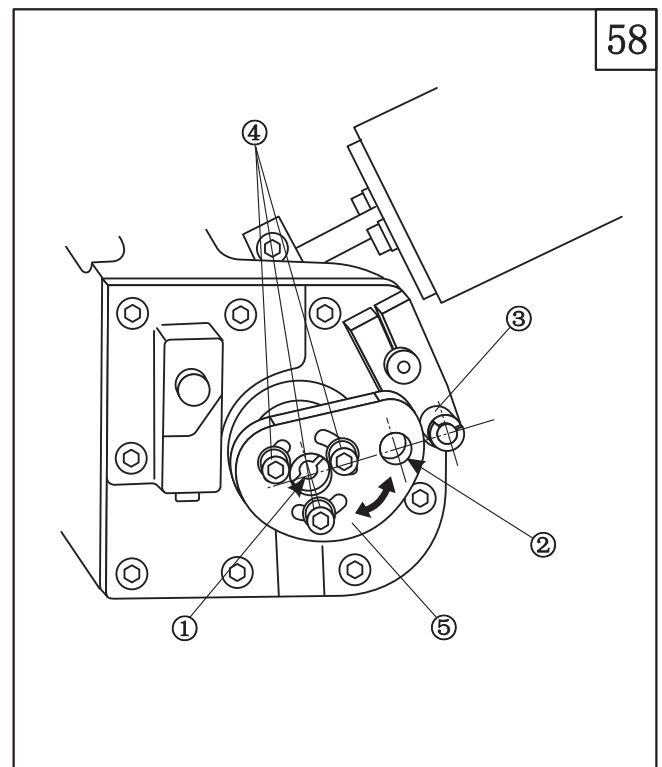

50. Adjusting the rotary hook lubrication amount (fig.59, 60)

1. Checking the lubrication amount

After adjusting the lubrication adjustment screw, run the sewing machine for approximately 1 minute to allow the lubrication amount to stabilize before checking the lubrication amount.

- a. Insert the lubrication amount check sheet ① from the right side of the rotary hook and hold it there. Then run the sewing machine at high speed for 10 seconds. (Any type of paper can be used as the lubrication amount check sheet)
- b. Check the amount of oil which has splattered onto the lubrication amount check sheet ①. (After approximately 10 seconds, the amount of oil splattered by the rotary hook should be as shown in the illustration.)

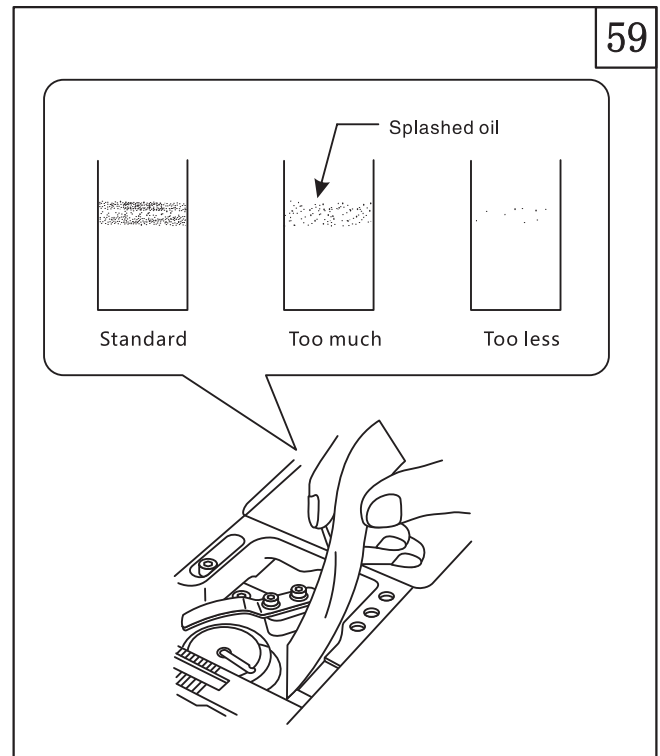

2. Adjusting the lubrication amount

- a. Open slide plates ② and ③.
- b. Turn the machine pulley to rotate the rotary hook until the lubrication adjustment screw ④ becomes visible.
- c. Turn the lubrication adjustment screw ④ approximately 45° to adjust the lubrication amount.
 - If the lubrication adjustment screw ④ is turned clockwise, the lubrication amount decreases, and if it is turned counterclockwise, the lubrication amount increases.
- d. Check the lubrication amount again according to the procedure given in "checking the lubrication amount" above and repeat the procedures until the lubrication amount is correct.

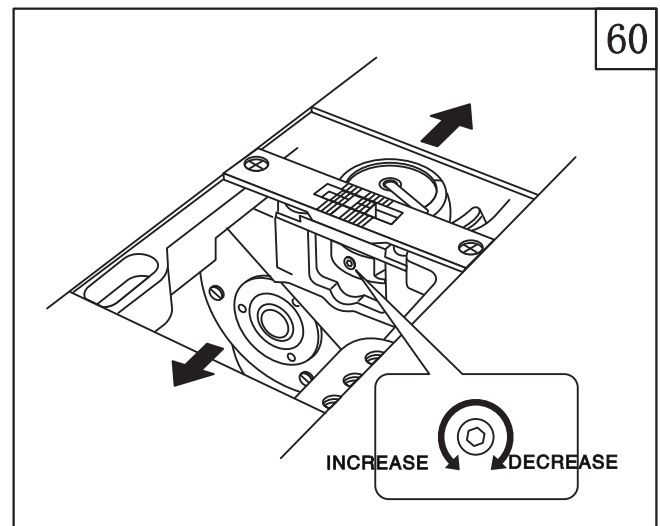

51. Removing the timing belt (fig.61, 62, 63, 64)

1. Removing the belt cover (For 898-D2, remove the synchronizer first).
2. Remove the upper cover.
3. Tilt back the machine head.
4. Remove the timing belt (1) from the lower belt pulley (2).
5. Loosen the screw (5) of the feed adjusting lever (4) which is attached to the reverse stitching lever shaft (3).

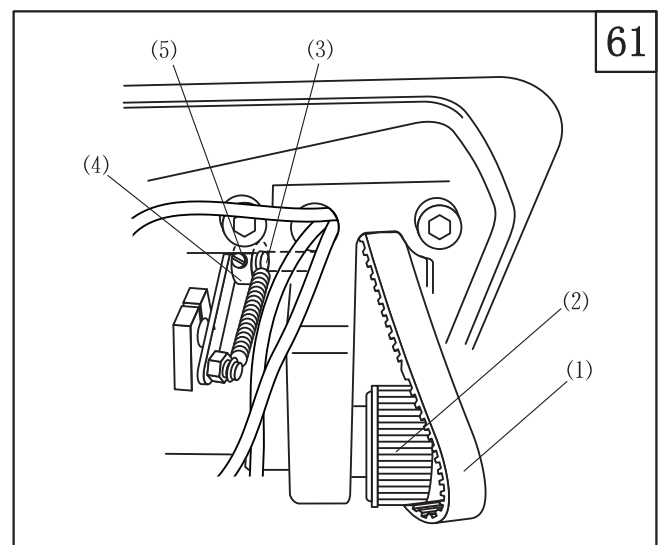

62

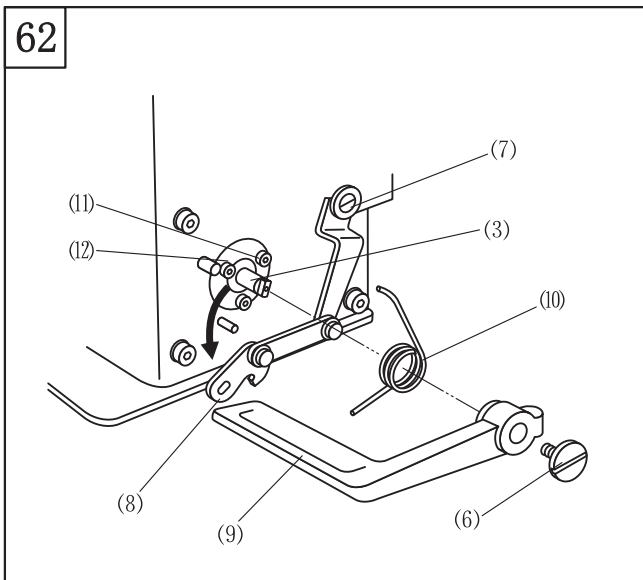

6. Remove the reverse stitching lever screw (6).
7. Loosen the screw (7) by half a turn, and then remove the reverse stitching lever plate (8) from the reverse stitching lever shaft (3).
- Be careful not to use too much force when removing the reverse stitching lever plate (8).
8. Remove the reverse stitching lever (9) and the spring (10).
9. Remove the three bolts (1), and then remove the washer (2).

63

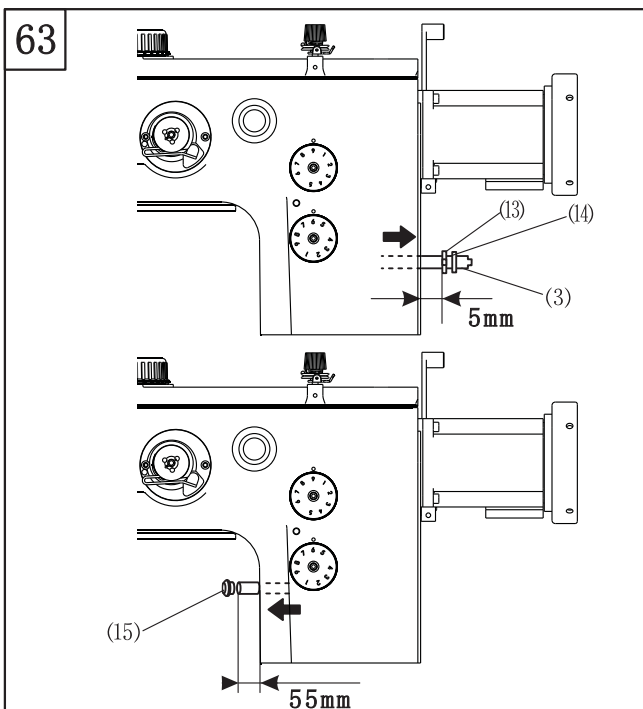

10. Pull the reverse stitching lever shaft (3) so that it projects 5 mm from retaining ring (13)
- If the reverse stitching lever shaft (3) is pulled out by more than 5 mm, the parts inside the arm will become disengaged and assembly will become more difficult.
- Be careful not to damage the reverse stitching lever shaft (3).
11. Remove the retaining ring (13) and washer (14) from the reverse stitching lever shaft (3).
12. Hold the flat parts at the end of the reverse stitching lever shaft (3) with pliers and turn the shaft while pushing it back inside the arm. (The rubber plug (15) will come out of the arm.)
13. Pull the reverse stitching lever shaft (3) 55mm out from the arm to allow space for the timing belt (1) to pass inside the arm.
- If the reverse stitching lever shaft (1) is pulled out more than 55 mm, the parts inside the arm will become disengaged and assembly will become more difficult.

64

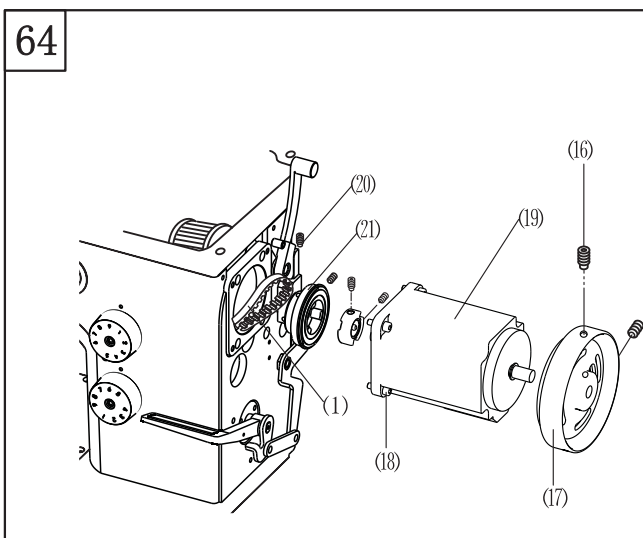

14. Loosen the 2 set screws (16), remove the screw (17) and washer (18), and then remove the machine pulley from upper shaft (19).
15. Loosen the 2 set screws (20) and then take out the bearing (21).
16. Remove the timing belt (1) from the hole in the arm.

52. Installing the timing belt(fig.65,66, 67,68,69)

- 1.Insert the new timing belt (1) into the hole in the arm, and provisionally hook it onto the upper belt pulley (22).
 - 2.Place the bearing (21) onto the upper flange, push the bearing (21) into the hole in the arm as far as the flange, and tighten the set screws (20).
 - 3.Place the coupling (28) of motor (27) 1nto the bearing(21)
- Note: Set the screw (20) in the V-groove of upper shaft when installing bearing(21), while insert the coupling(28), the screw position should be matched.
- 4.Set the feed adjustment dial to the "3" Position.

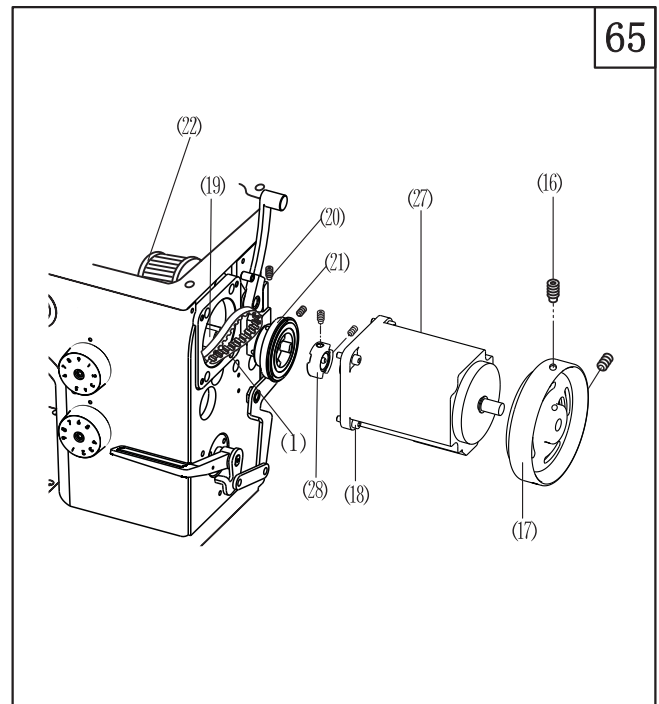

- 5.Insert the reverse stitching lever shaft (3) through the loop of the timing belt (1).
 - 6.Push the reverse stitching lever shaft (3) out 5 mm from the groove for installing retaining ring (13).
- If the reverse stitching lever shaft (3) is pulled out by more than 5 mm, the parts inside the arm will become disengaged and assembly will become more difficult.
- 7.Install retaining ring (13) to the reverse stitching lever shaft (3).
 - 8.Push the reverse stitching lever shaft (3) all the way into the arm. (Push in until retaining ring (13) is against the deepest part of the hollow.)
 - 9.Place the washer (14) onto the reverse stitching lever shaft (3).
 - 10.Place the washer (12) onto the reverse stitching lever shaft (3), and then tighten the bolt (11).
 - 11.Check that the reverse stitching lever shaft (3) turns easily.

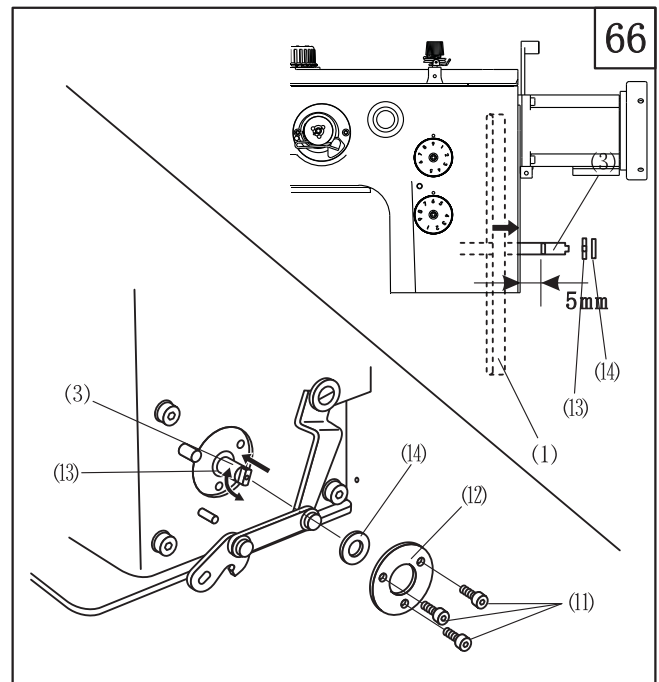

- 12.Hook the spring (10) onto the reverse stitching lever (3) and stop in (23) as shown in the illustration, and then insert the reverse stitching lever (9) onto the reverse stitching lever shaft (3).
- 13.Place the reverse stitching lever plate (8) onto the reverse stitching lever shaft (3), and then tighten the reverse stitching lever screw (6).
- 14.Tighten the screw (7).

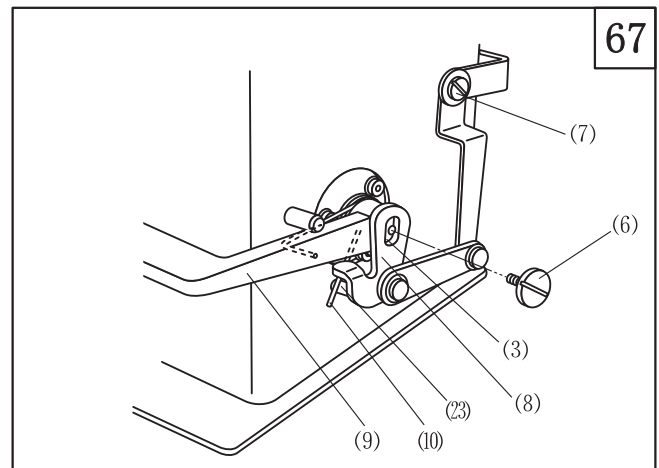

68

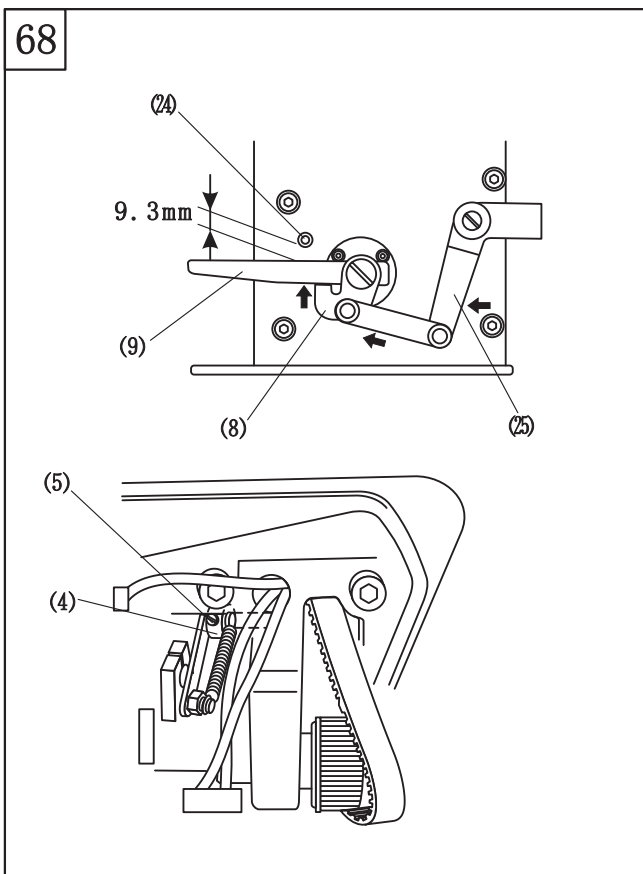

15. Set the feed adjustment dial to the minimum.
 16. Tilt back the machine head.
 17. Set that the distance between the reverse stitching lever (9) and the stop pin (24) to 9.3 mm, and then push the connecting plate (25) so that the reverse stitching lever plate (8) touches against the reverse stitching lever (9).

In this condition, tighten the screw (5) of the feed adjusting lever (4).
 18. Set the feed adjustment dial to the maximum.
 19. Push the reverse stitching lever (9) and check that it moves easily.
 Note: If it moves stiffly, it indicates that the feed adjusting lever (4) was moved to the left and right in step 17, so carry out the following to adjust.
 a. Set the feed adjustment dial to the minimum.
 b. Tilt back the machine head.
 c. Loosen the screw (5) and then move the feed adjusting lever (4) to the left or right to adjust.
 d. Repeat the procedure in steps 17 to 19.

69

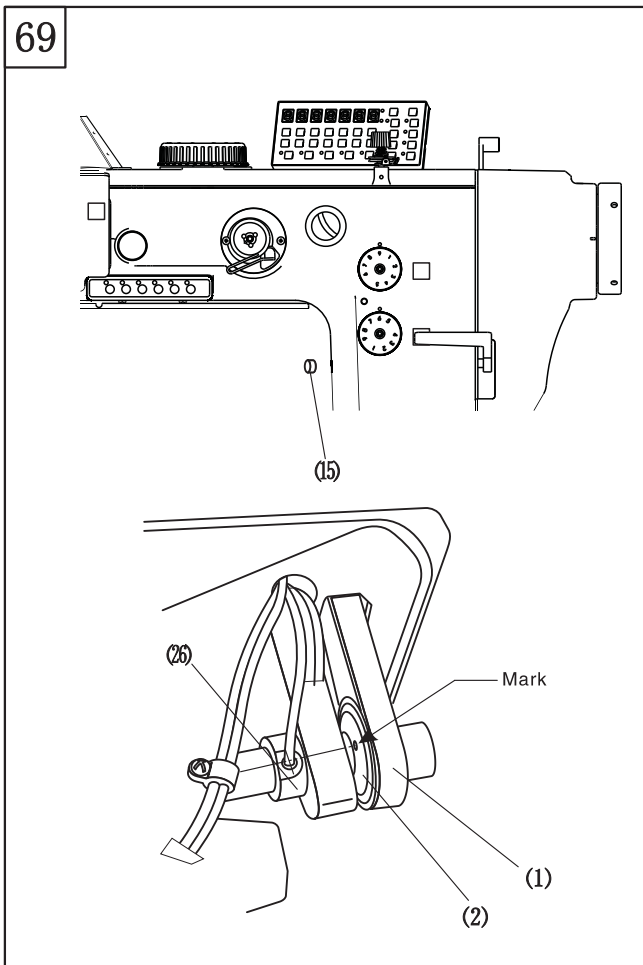

20. Install the rubber plug (14) to the arm.
 21. Turn the machine pulley to move the thread take-up lever to its highest position.
 22. Turn the lower belt pulley (2) to align the "-" mark on the left side of the lower pulley (2) with the center line of the oil tube setting hole in lower shaft bushing (26).
 23. In this position, hook the timing belt (1) onto the lower belt pulley (2).
 24. Carry out a test sewing and check that the stitch lengths are the same when sewing forward and backtacking.

If the forward and backtack stitch lengths are different, Repeat the procedure from step 17 to adjust.

25. After setting the alternating presser foot movement dial to the "1" position, install the upper plate.
 26. Install the motor covers.

53. Change of needle gauge parts (fig. 70, 71, 72, 73)

1. Install parts (1)~(8) as per illustration.
Note: Needle clamp (2) should be set by hexagonal screw. Loosen screw (10) in needle bar (9) first.
2. Tilt down machine head.

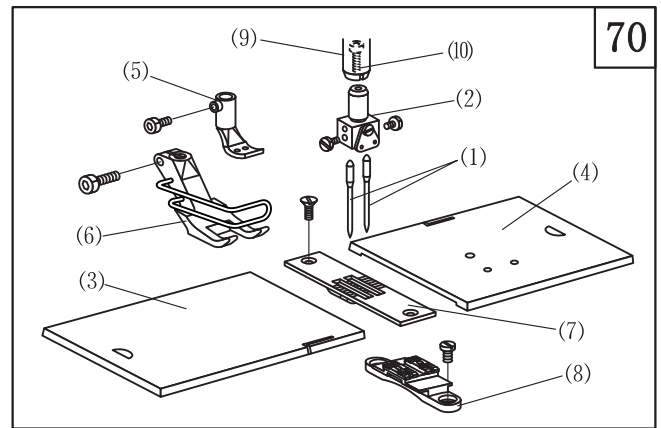

3. Loosen screw (11) and (12).

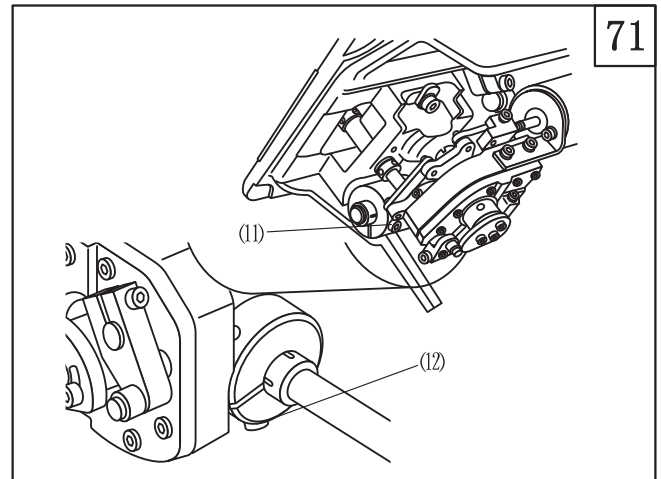

4. Loosen screw (15) and (16) so that hook base (13) and (14) can move to left or right.
5. Install the new needle plate and feed dog.

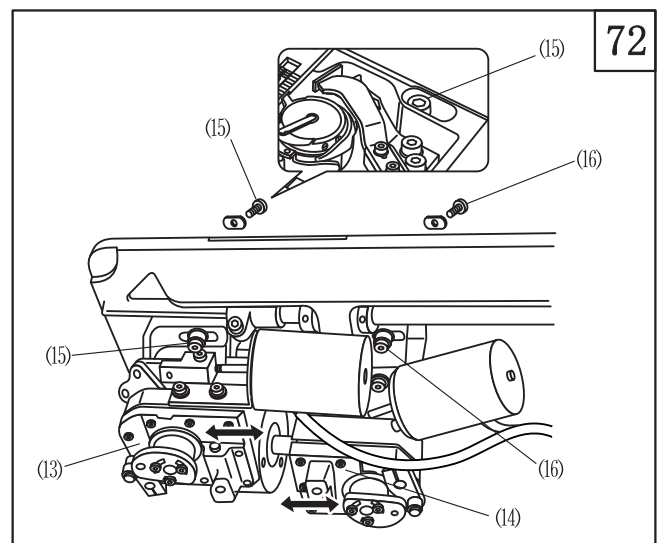

6. Insert needle clamp (2) into needle bar (9) and fix with hexagonal screw (10), and wedge the projection into the notch A of needle bar.
7. Set needles to needle clamp (2).
8. Readjust needle bar height, needle and hook timing, needle guard and thread opener
9. Install the new presser feet.

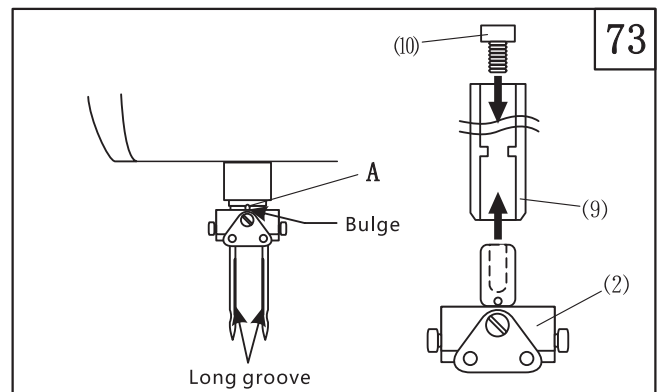

74

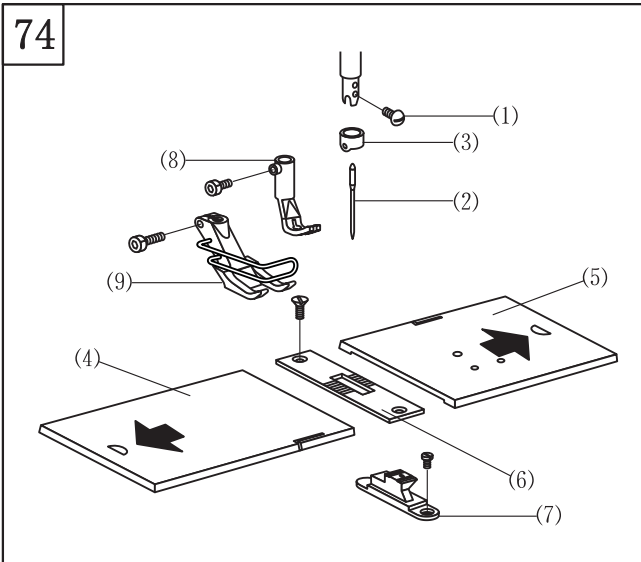

54. Change 1-needle gauge parts to 2-needle set (fig.74, 75,76,77,78,79,80,81,82,83)

1. Uninstall parts (1)~(9) as per illustration.
2. Tilt down machine head.

75

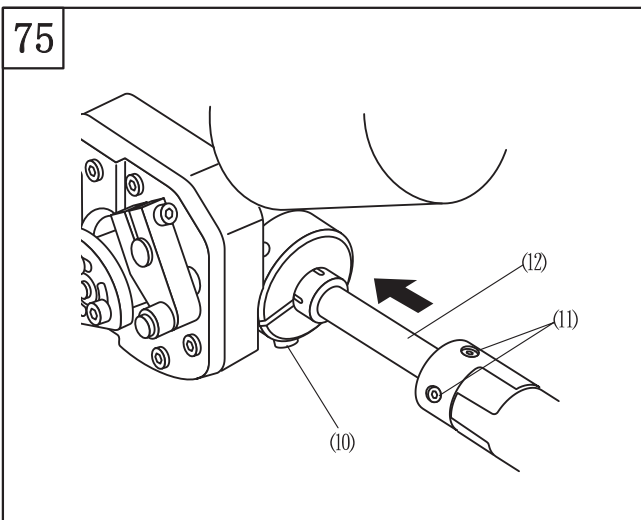

3. Loosen screw (10) and (11).
4. Pull out lower shaft (12) from left side.

76

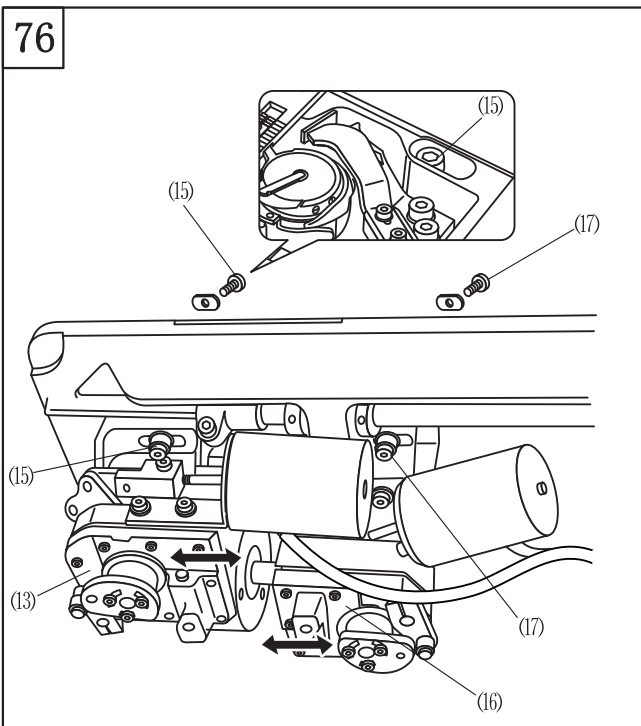

5. Fix hook saddle (14) with screw (15) provisionally.
6. Loosen screw (17) so that hook saddle (16) can be moved to left or right.
7. Install needle plate and feed dog of 2-needle machine

8. Loosen screw (18), pull needle bar (19) up.
9. Insert needle bar (20) for 2-needle machine and tighten screw (18).

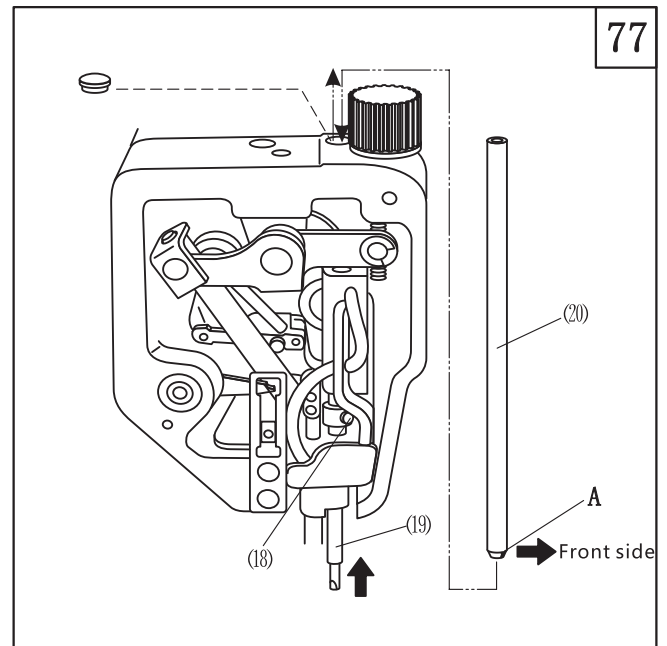

10. Fix needle clamp (21) to needle bar (20) with hexagonal screw (22).
11. Insert 2 piece of needles into needle clamp (21).

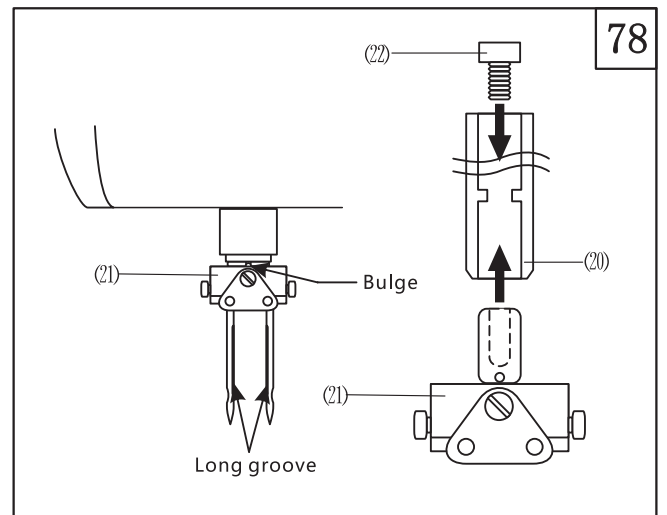

12. Insert lower shaft (21) of 2-needle machine through hook saddle (14) and (16).
13. Tighten the shaft with screw (11). Setscrew should overlap with point B.
14. Readjust related parts.

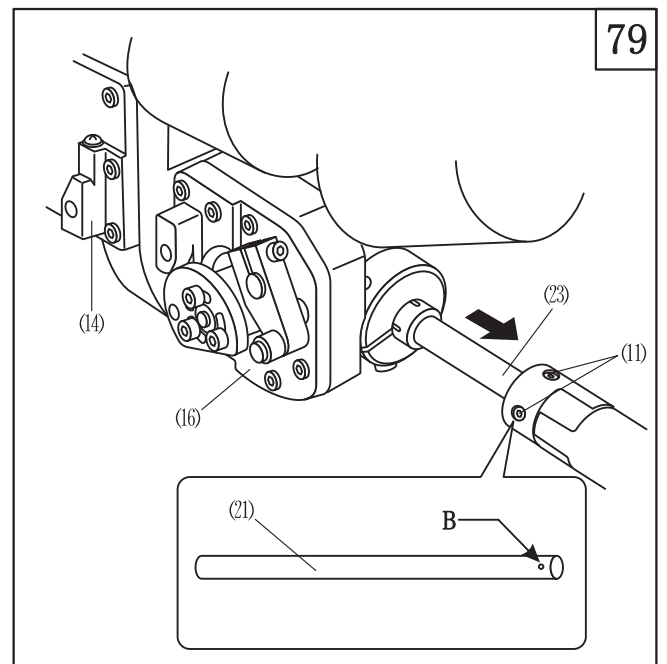

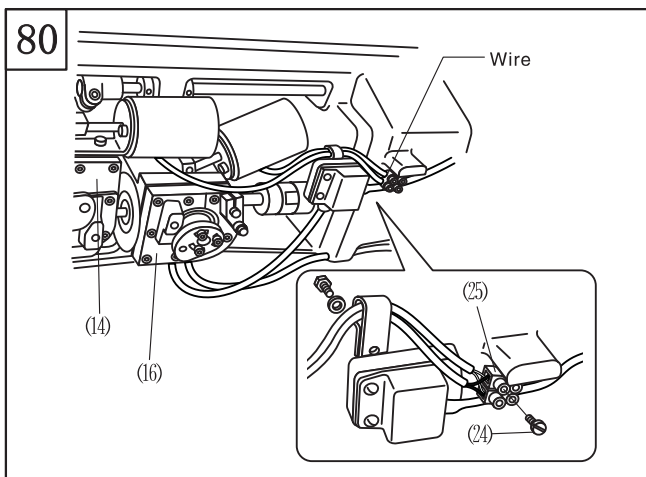

15. For models with automatic trimmer, wires from hook saddle (14) and (15) should be fixed to the terminal base (25) by screw (24).

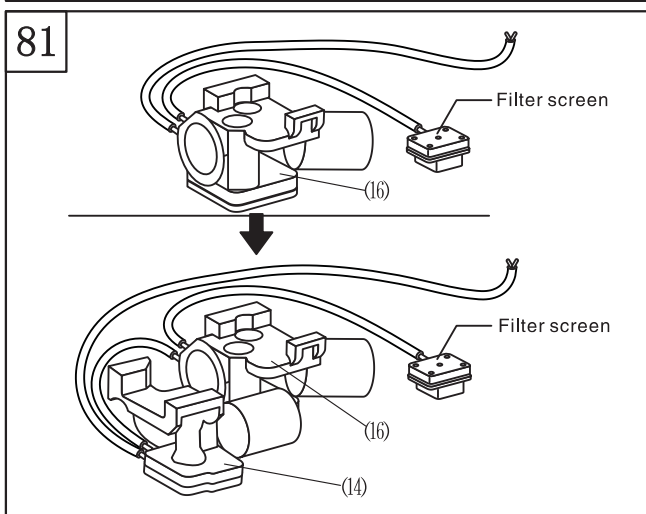

16. Take off nylon tube 400, connect tube 170 to 490.

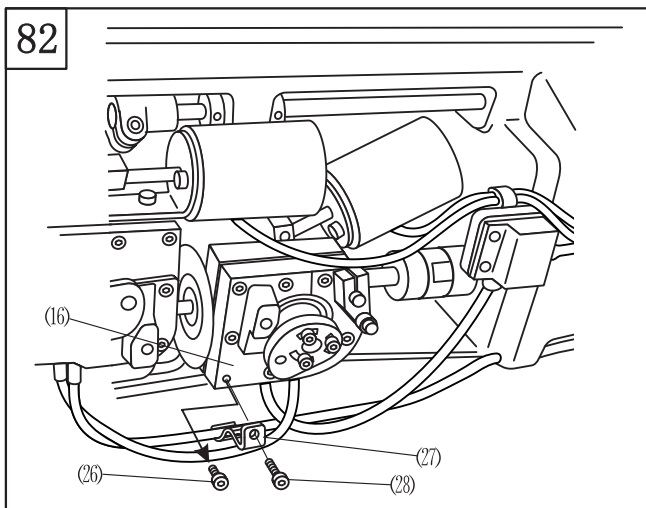

17. Remove hexagonal screw (26) from hook saddle (16).
18. Fix tube 490 to saddle base (16) with accessory (27) and hexagonal screw (28).

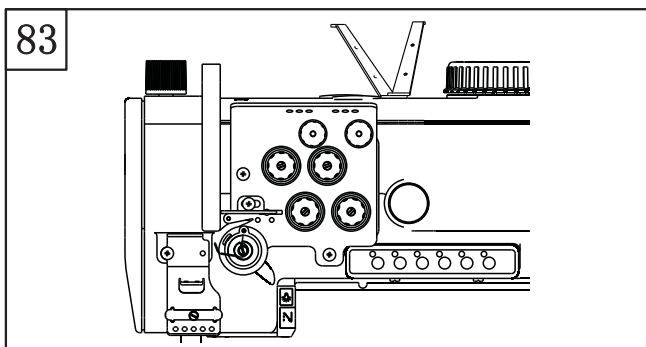

19. Install thread guide and tension set as per illustration.
20. Readjust all related parts.
21. Install the presser feet of 2-needle machine

55. Safety equipment(fig.84)

If the thread becomes tangled up in the rotary hook during sewing, the lower belt pulley safety equipment will operate to protect parts such as the rotary hook and the timing belt from damage. The lower shaft will stop rotating, and only the lower belt pulley will rotate in idleness.

1. Resetting the safety equipment

a. Remove the thread which has become tangled up in the rotary hook.

● Do not use a sharp-tipped instrument to do this, otherwise the rotary hook may become damaged.

b. Insert a screwdriver into the hole in the lower belt shaft ①, hold the screwdriver so that it does not turn, and then turn the machine pulley in reverse (clockwise) by hand.

c. Turn the machine pulley again but harder. The safety equipment will then be reset.

(Check that the lock lever ② is fitting securely into the groove of the lower belt shaft ①.)

2. Safety equipment engagement strength

The engagement strength of the safety equipment is weakest when the arrow on the lock lever spring shaft ③ is pointing toward the center of the shaft ④, and strongest when it is pointing toward the outside.

a. Turn the machine pulley to the position where an Allen key can be inserted into the set screw ⑤.

⑤.

b. Loosen the set screw ⑤, and then turn the lock lever spring shaft ③ to adjust.

c. After adjusting, securely tighten the set screw ⑤.

⑤.

84

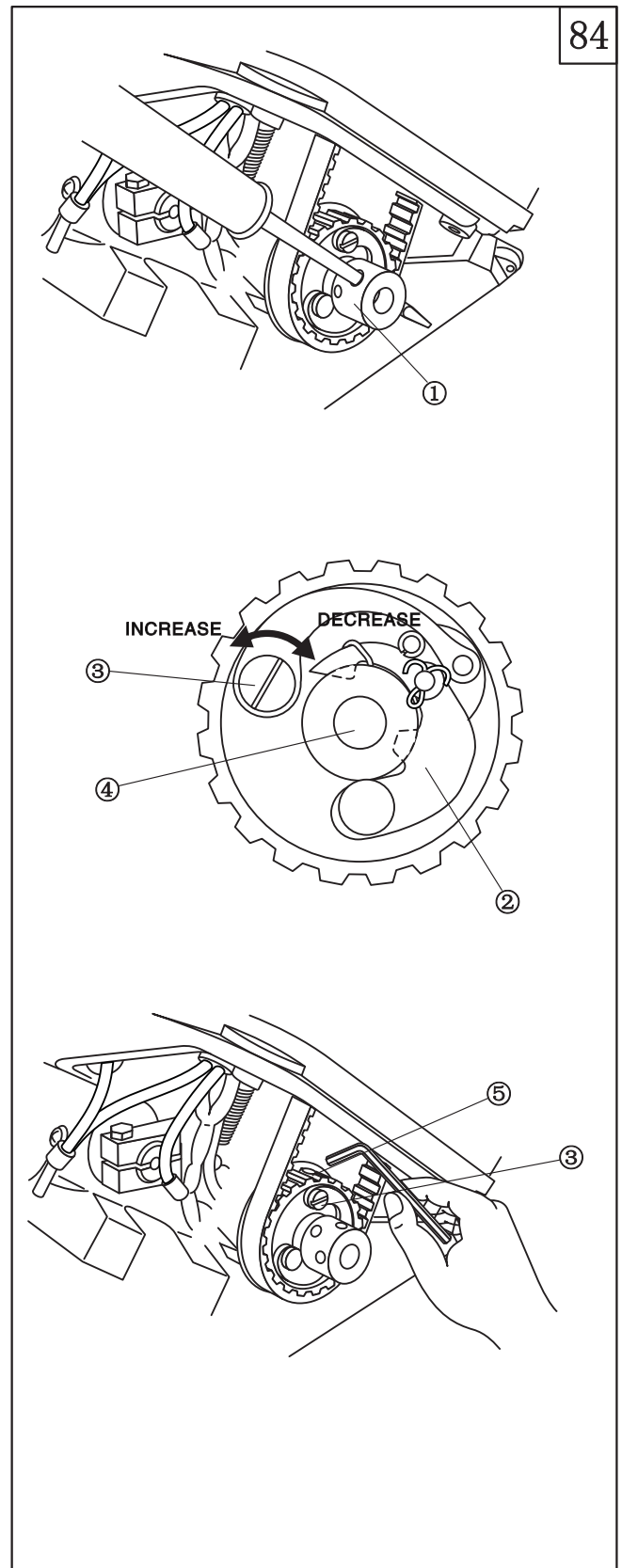

Parts Manual

1. Machine body

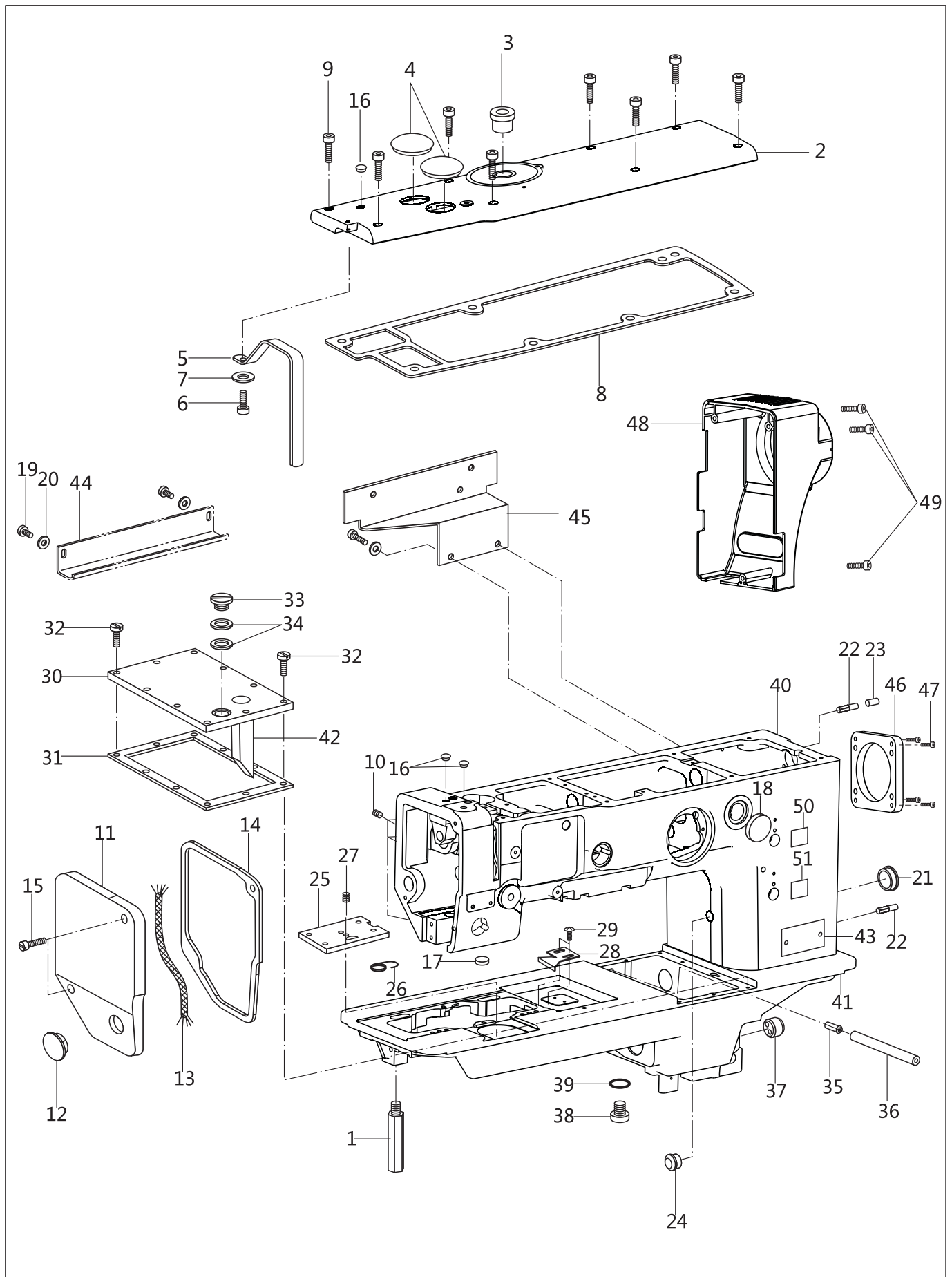

1. Machine body

NO.	PARTS NO.	PARTS NAME	QTY		REMARK
			TW 1- 898L14D2T5	TW 2- 898L14D2T5	
1	93WF1-021	Support bar	1	1	
2	394WF1-003	Top cover	1	1	
3	93WF1-001	Dial bushing	1	1	
4	93WF1-002	Rubber cap, 32.8	2	2	
5	93WF1-023	Thread take-up lever cover	1	1	RAL7015
6	93WF1-024	Bolt	1	1	
7		Washer	1	1	GB/T 97.1 4
8	304WF1-002	Sheet packing	1	1	
9	93WF1-026	Bolt	8	8	
10	93WF1-027	Set screw	4	4	
11	93WF1-028	Face plate	1	1	
12	93WF1-004	Rubber cap, 20.5	2	2	
13		Oil wick	1	1	L=130
14	93WF1-005	Packing	1	1	
15	93WF1-029	Bolt	2	2	
16	93WF1-006	Rubber cap, 9.5	3	3	
17	93WF1-007	Rubber cap	1	1	
18	93WF1-008	Oil window	1	1	
19	13WF2-008	Screw	2	2	SM9/64"×40
20	93WF1-009	Washer	2	2	
21	93WF1-010	Rubber cap	2	2	
22	2KT3-006	Pin	3	3	140063-0
23	2KT3-007	Nylon tube	2	2	153132-0
24	93WF1-11	Rubber cap, 10.5	1	1	
25	93WF1-032	Slide plate	1	1	
26	93WF1-012	Spring	1	1	
27		Set screw	1	1	GB/T 77 M4×5
28	93WF1-013	Stopper	1	1	
29	33T3-007	Screw	2	2	SM9/64"×40
30	93WF1-034	Upper cover assy.	1	1	
31	93WF1-014	Sheet packing	1	1	
32	93WF1-024	Bolt	10	10	
33	93WF1-015	Screw	1	1	
34	93WF1-016	Packing	2	2	
35	93WF1-017	Pipe	1	1	
36		Tube	1	1	L=120
37	93WF1-018A	Oil cap	1	1	
38	93WF1-019	Screw	1	1	
39		O-ring	1	1	6.9×1.8A GB 3452.1
40	394WF1-001	Machine arm	1	1	
41	379WF1-002	Machine bed	1	1	
42	93WF1-050	Oil gauge	1	1	
43	446WF1-008	Model label	1	1	
	446WF1-009	Model label	1	1	
44	411WF1-008	Wire cover	1	1	
45	394WF24-001	Plate	1	1	
46	394WF1-004	Bracket for motor	1	1	
47	93WF7-014	Screw	4	4	
48	394WF1-005	Motor cover	1	1	
49	93WF19-008	Screw	3	3	
50	411WF1-005	Label	1	1	
51	411WF1-006	Label	1	1	

2. Upper shaft mechanism

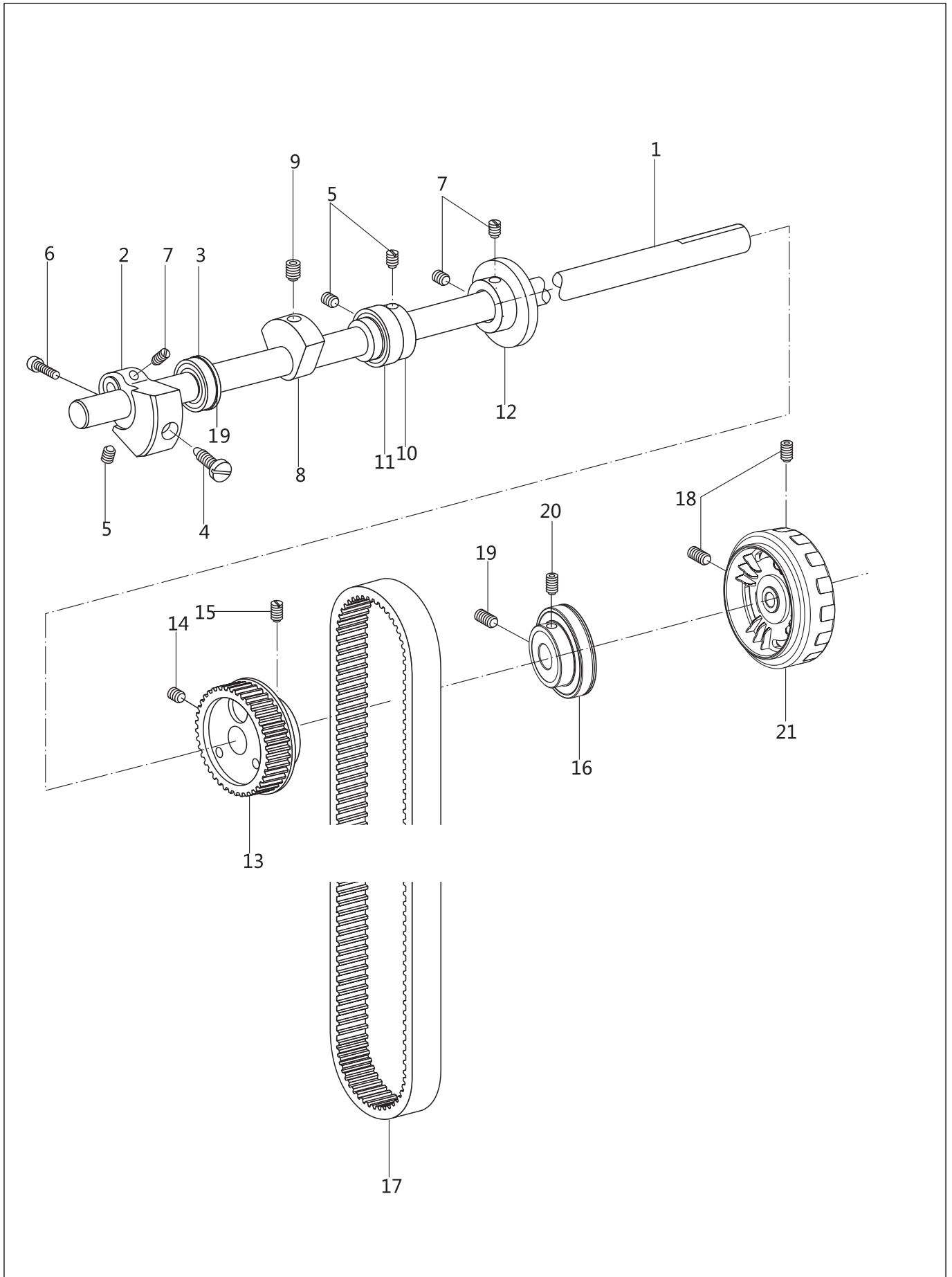

2. Upper shaft mechanism

NO.	PARTS NO.	PARTS NAME	QTY		REMARK
			TW 1- 898L14D2T5	TW 2- 898L14D2T5	
1	394WF2-002	Upper shaft	1	1	6204-2ZNR 20X47X14
2	93WF2-005	Crank motion cam	1	1	
3		Bearing, upper shaft	1	1	
4	93WF2-001	Screw	1	1	
5	93WF1-027	Set screw	5	5	
6	93WF1-026	Bolt	2	2	GB/T 80 M8x12
7	93WF2-008	Set screw	3	3	
8	93WF2-009	Balancer	1	1	
9		Set screw	1	1	
10	93WF2-011	Collar, middle upper shaft	1	1	
11	93WF2-012	Bearing	1	1	
12	93WF2-013	Collar, bobbin winder	1	1	
13	93WF2-002	Upper belt pulley	1	1	
14	93WF2-014	Set screw	2	2	
15	93WF2-015	Set screw	1	1	
16	394WF2-001A	Bearing	1	1	53.3×57.8×0.8
17	93WF2-003	Timing belt	1	1	M6X0.75
18	93WF5-030	Set screw	2	2	
19	93WF15-011	Screw	1	1	
20	93WF15-012	Screw	1	1	
21	258WF2-006	Handwheel	1	1	

3. Upper feed mechanism

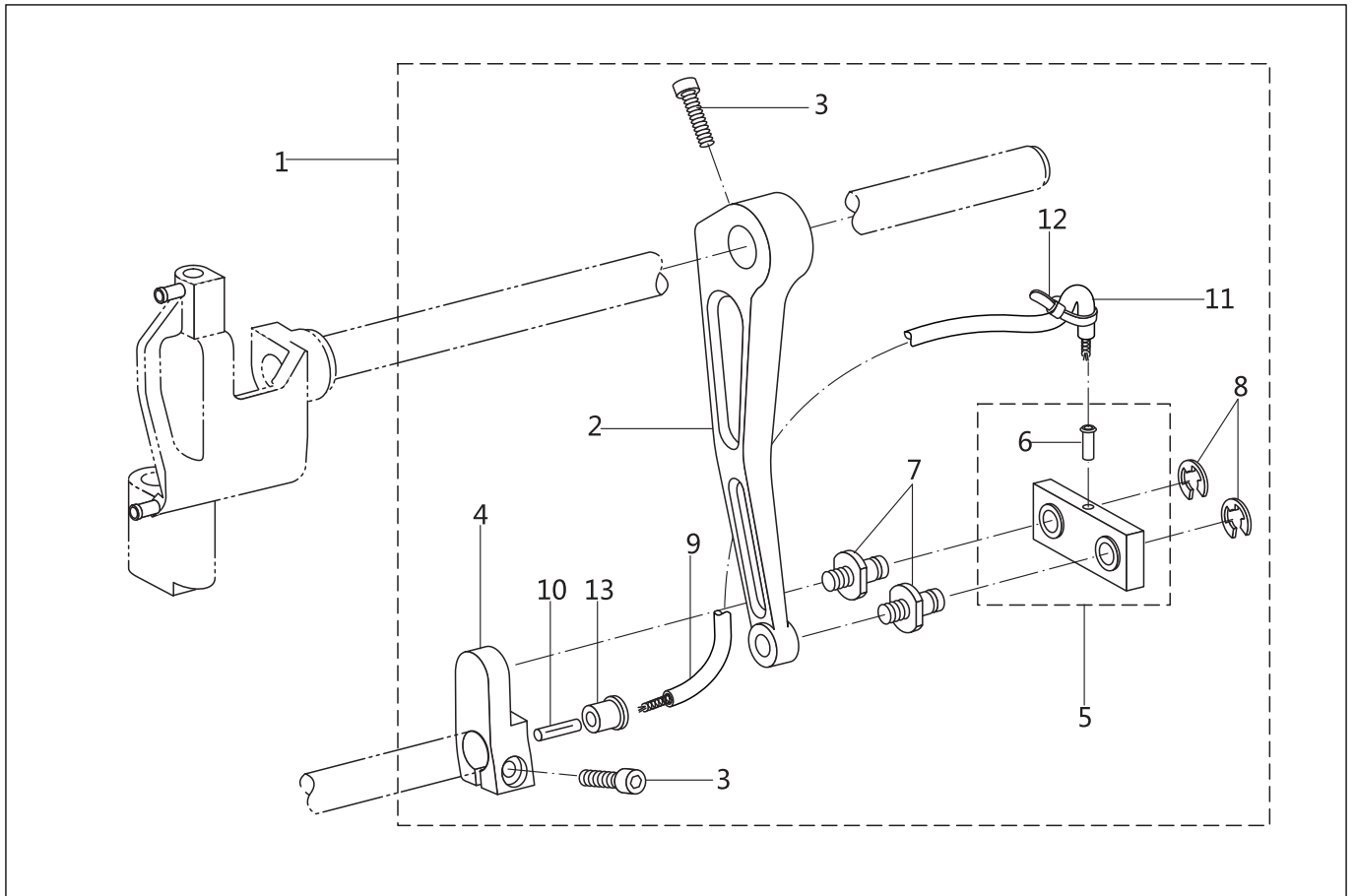

NO.	PARTS NO.	PARTS NAME	QTY		REMARK
			TW 1- 898L14D2T5	TW 2- 898L14D2T5	
1	93WF3-003	Upper feed connecting rod assy.	1	1	
2	93WF3-004	Upper feed connecting rod	1	1	
3	93WF3-005	Bolt	2	2	
4	93WF3-006	Connecting lever	1	1	
5	93WF3-007	Upper feed connection assy.	1	1	
6	93WF3-001	Pipe	1	1	
7	93WF3-002	Shoulder screw	2	2	
8		Retaining ring	2	2	GB 896 8
9		Tube	1	1	L=250
10		Felt	1	1	3×8
11		Oil wick	1	1	L=170
12	258753	Fastening band	1	1	
13	93WF3-010	Rubber cap	1	1	

4. Quick reverse mechanism

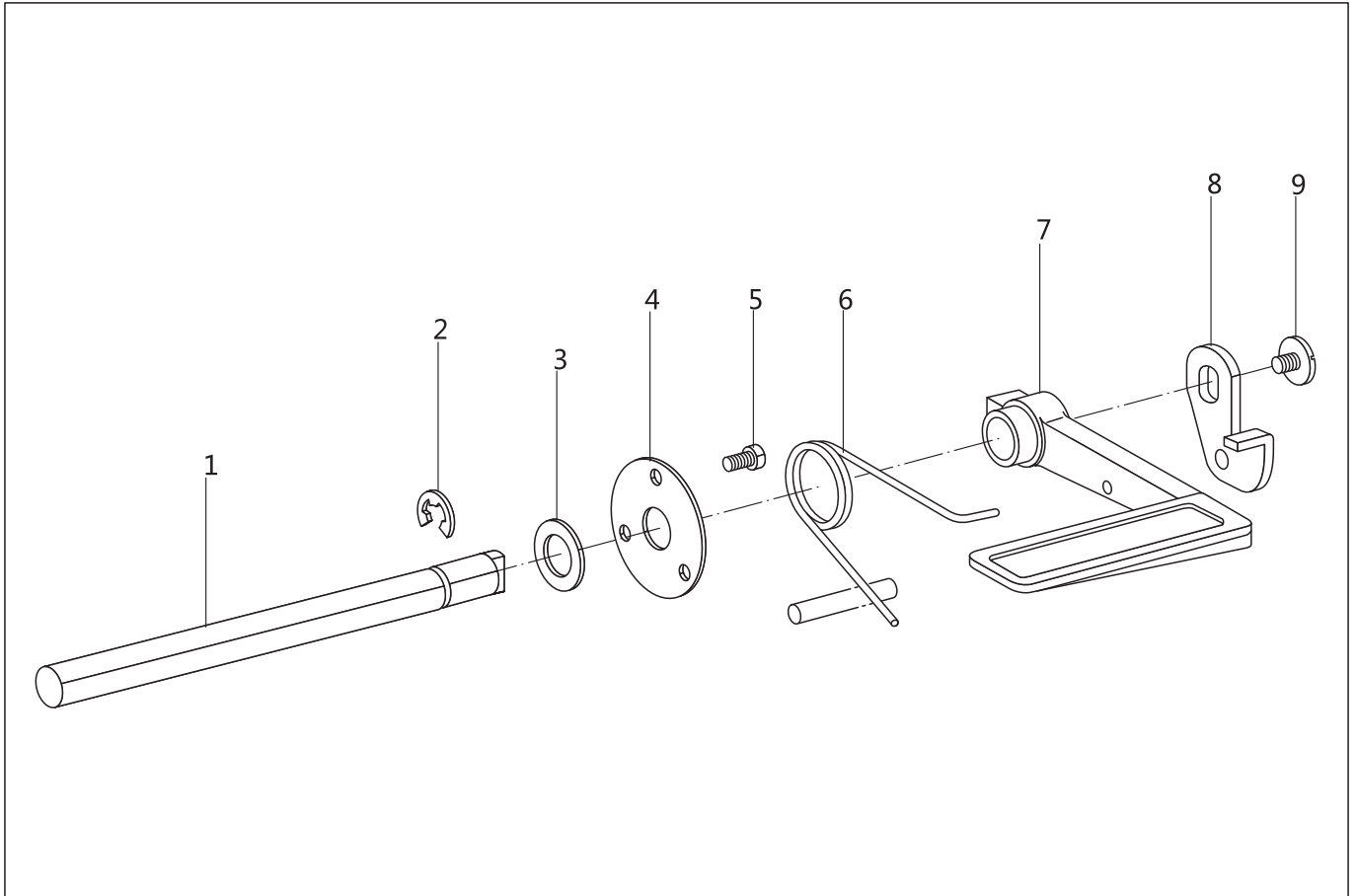

NO.	PARTS NO.	PARTS NAME	QTY		REMARK
			TW 1- 898L14D2T5	TW 2- 898L14D2T5	
1	93WF4-003	Shaft, Reverse stitching lever	1	1	
2	93WF4-004	Retaining ring	1	1	
3	93WF4-001	Washer	1	1	
4	93WF4-002	Spacer	1	1	
5		Bolt	3	3	GB/T 70.1 M4×6
6	21WF3-043	Spring	1	1	
7	62WF2-003	Reverse stitching lever	1	1	RAL7015
8	62WF5-024E	Reverse stitching lever plate	1	1	100511-003
9	2KT3-005	Screw	1	1	

5. Needle bar and thread take-up mechanism

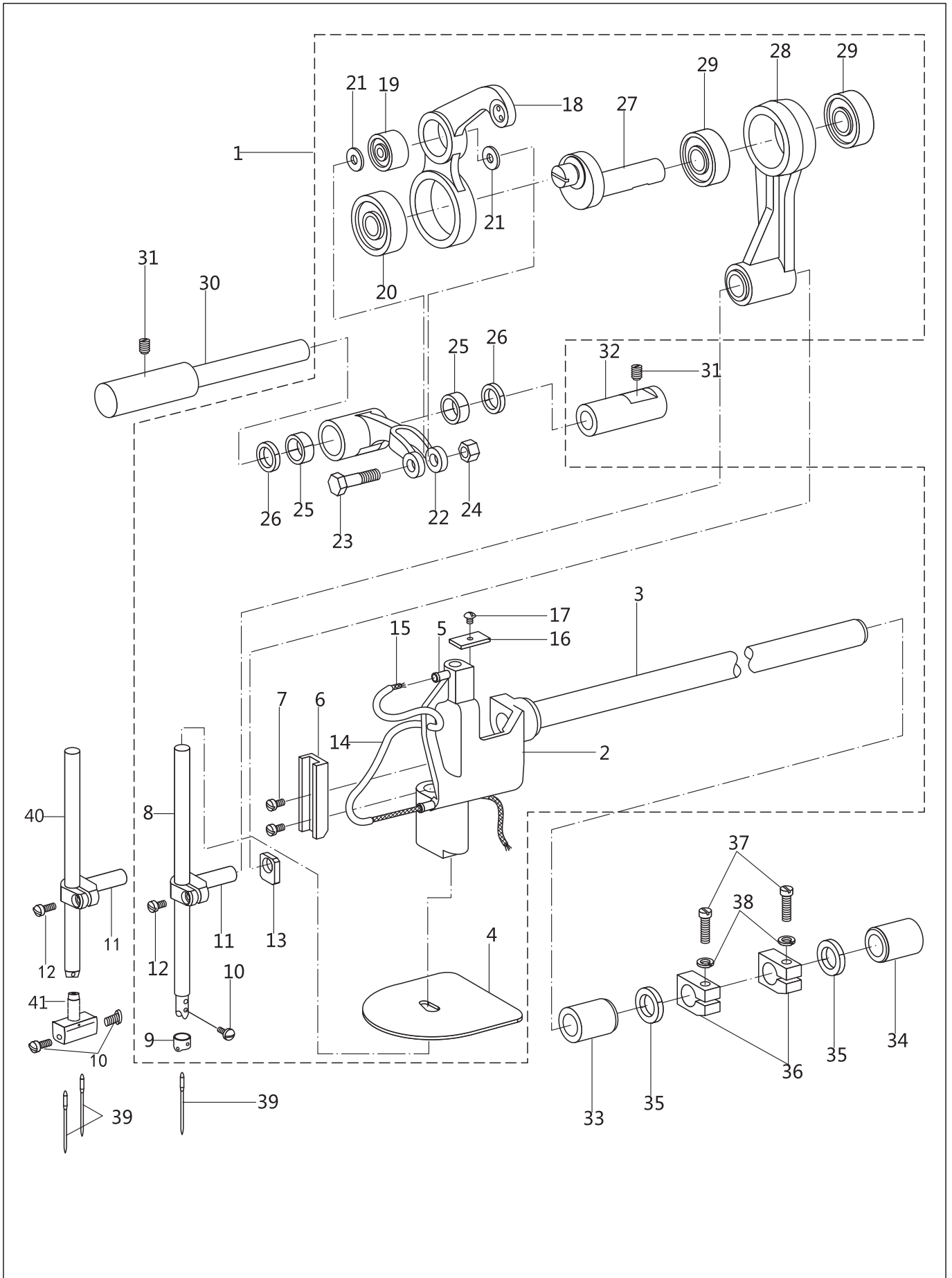

5. Needle bar and thread take-up mechanism

NO.	PARTS NO.	PARTS NAME	QTY		REMARK
			TW 1- 898L14D2T5	TW 2- 898L14D2T5	
1		Needle bar bracket assy.	1	1	
2	93WF5-010	Needle bar bracket	1	1	
3	304WF5-001	Needle bar bracket shaft	1	1	
4	93WF5-001	Rubber sheet	1	1	
5	93WF3-001	Pin	2	2	
6	93WF5-012	Guide rail	1	1	
7	491115	Screw	2	2	
8	93WF5-014	Needle bar	1	-	
9	93WF5-002	Thread guide, N-bar	1	1	
10	17WF2-037	Set screw	1	2	
11	93WF5-015	Needle bar clamp	1	1	
12	13WF3-018	Screw	1	1	
13	93WF5-016	Slide block, N-bar clamp	1	1	
14		Oil tube	1	1	L=110
15		Oil wick	1	1	L=700
16	93WF5-003	Sponge	1	1	
17		Screw	1	1	GB/T 65 M4×6
18	93WF5-018	Thread take-up lever complete	1	1	
19	93WF5-034	Bearing, S, T-take-up	1	1	80024 4×13×5
20	93WF5-035	Bearing, L, T-take-up	1	1	80018 8×22×7
21		Washer, T-take-up	2	2	GB/97.1 4
22	93WF5-022	Thread take-up support	1	1	
23	93WF5-023	Support screw	1	1	
24	11KT3-021	Nut	1	1	GB/T 6170 M4
25		Needle bearing	2	2	29241/7 7×10×8
26	93WF5-004	Support ring	2	2	
27	93WF5-026	Crank	1	1	
28	93WF5-027	Needle bar crank rod assy.	1	1	
29	93WF5-028J	Bearing	2	2	698-2Z 8×19×6
30	93WF5-029	Pin, T-take-up	1	1	
31	93WF5-030	Set screw	2	2	
32	93WF5-005	Bushing, T-take-up pin	1	1	
33	93WF5-006	Bushing	1	1	
34	93WF5-007	Bushing	1	1	
35	93WF5-008	Ring	2	2	
36	93WF5-031	Collar	2	2	
37	93WF1-029	Bolt	2	2	
38		Washer, spring	2	2	GB 859 5
39		Needle	1	2	DP×17 19#
40	179WF5-001	Needle bar	-	1	
41	193WF13-001e	Needle clamp	-	1	

6. Presser bar mechanism

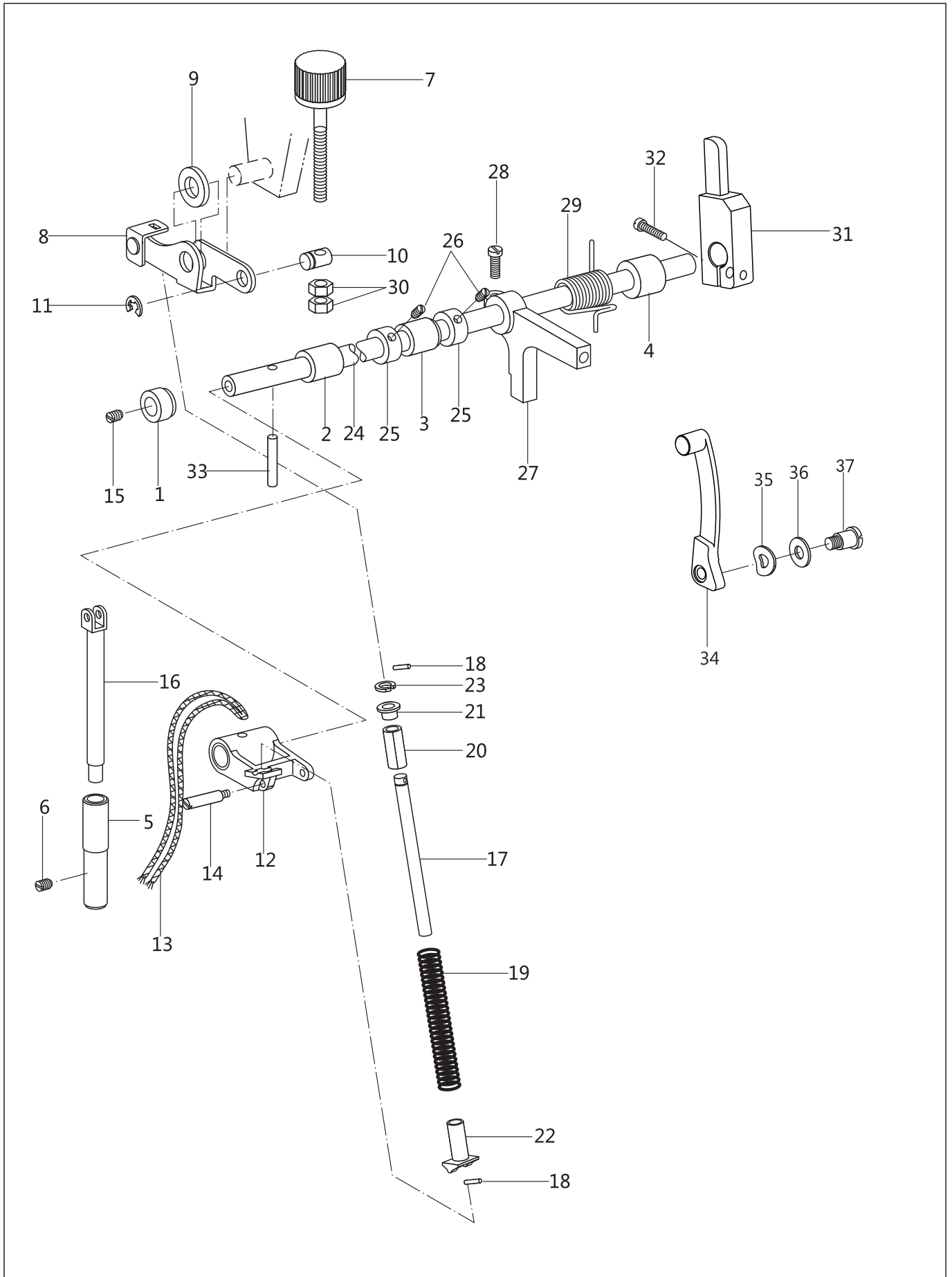

6. Presser bar mechanism

NO.	PARTS NO.	PARTS NAME	QTY		REMARK
			TW 1- 898L14D2T5	TW 2- 898L14D2T5	
1	93WF6-001	Bushing A, P-foot lifter shaft	1	1	
2	93WF6-002	Bushing B	1	1	
3	93WF6-003	Bushing C, P-foot lifter shaft	1	1	
4	93WF6-004	Bushing D	1	1	
5	93WF6-021	Bushing, P-bar	1	1	
6	93WF5-030	Set screw	1	1	
7	93WF6-005b	Pressure adjusting dial	1	1	RAL7015
8	93WF6-022	Pressure adjusting plate assy.	1	1	
9	93WF6-006	Felt	1	1	
10	93WF6-023	Pin	1	1	
11	93WF6-007	Retaining ring	1	1	
12	93WF6-024	P-foot lifter connection assy.	1	1	
13		Oil wick	1	1	L=400
14	93WF6-025	Pin	1	1	
15	93WF2-015	Set screw	1	1	
16	93WF6-026	Presser bar	1	1	
17	93WF6-027	Shaft, presser bar spring	1	1	
18		Pin	2	2	GB/T 879.1 3×8
19	93WF6-008	Presser spring	1	1	
20	93WF6-009	Collar	1	1	
21	93WF6-029	Spring support, U	1	1	
22	93WF6-028	Spring support, D	1	1	
23	35WF4-005	Retaining ring	1	1	
24	304WF6-001	Presser bar lifter shaft	1	1	
25	93WF6-010	Set screw collar	2	2	
26	93WF2-008	Set screw	2	2	
27	93WF6-034	Knee lifter arm, U	1	1	
28	93WF6-035	Bolt	1	1	
29	93WF6-036	Spring	1	1	
30		Nut	2	2	GB/T 6172 M6
31	394WF6-002	Presser bar lifter cam, U	1	1	
32	93WF6-042	Bolt	1	1	
33	93WF6-020	Pin	1	1	
34	394WF6-001	Presser bar lifting bar	1	1	
35	93WF6-044	Washer	1	1	
36	93WF6-015	Washer	1	1	
37	93WF6-013	Screw	1	1	

7. Feed mechanism

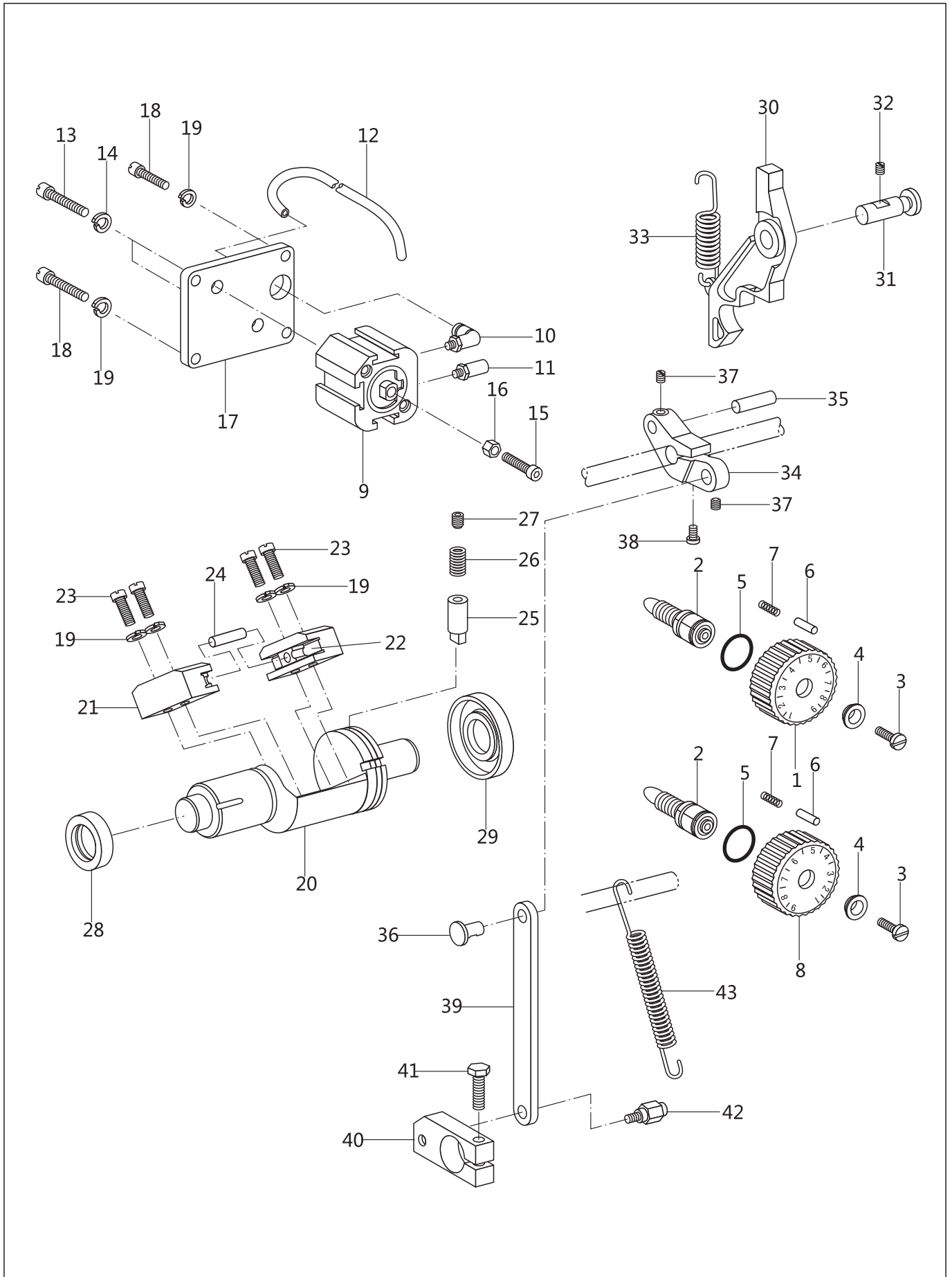

7. Feed mechanism

NO.	PARTS NO.	PARTS NAME	QTY		REMARK
			TW 1- 898L14D2T5	TW 2- 898L14D2T5	
1	93WF7-001b	Feed adjusting dial, U	1	1	RAL7015
2	93WF7-005	Adjusting screw bar	2	2	
3	93WF7-002	Screw	2	2	
4	36T5-007D4	Bushing	2	2	
5	124T5-00A3	O ring	2	2	
6	93WF7-006	Positioning pin	2	2	RAL7015 SDA25×10 SU045 PL4-M5
7	21WF3-046	Spring, compression	2	2	
8	93WF7-003b	Stitch dial, D	1	1	
9	93WF7-007	Cylinder	1	1	
10	93WF7-008	Joint	1	1	BSLM-M5 L=1000 GB 955 6
11	93WF7-009	Silencer	1	1	
12		Tube	1	1	
13	93WF3-005	Bolt	2	2	
14		Washer	2	2	
15	93WF3-005	Bolt	1	1	GB/T 6172 M6 GB 859 5
16		Nut	1	1	
17	994194	Setting plate	1	1	
18	93WF7-014	Bolt	4	4	
19		Washer	8	8	
20	93WF7-015	Roller	1	1	
21	93WF7-016	Guide rail	2	2	
22	93WF7-017	Guide rail	2	2	
23	93WF1-029	Bolt	4	4	
24	93WF7-018	Pin	1	1	GB/T 77 M10×10 20×30×7 20×47×7
25	93WF7-019	Cylinder guide pin	1	1	
26	93WF7-020	Spring	1	1	
27		Set screw	1	1	
28	93WF7-022	Oil seal, front	1	1	
29	93WF7-023	Oil seal, back	1	1	
30	93WF7-024	Feed adjustment arm	1	1	
31	93WF7-025	Pin	1	1	
32	93WF1-027	Set screw	1	1	GB/T 65 M5×25
33	93WF7-026	Spring	1	1	
34	93WF7-027	Feed adjusting lever	1	1	
35	93WF7-004	Needle roller	1	1	
36	93WF7-028	Link pin	1	1	
37	93WF7-029	Set screw	2	2	
38		Screw	1	1	
39	93WF7-031	Feed adjusting connection rod	1	1	
40	93WF7-032	Connecting block	1	1	
41	93WF7-033	Bolt	1	1	
42	93WF7-034	Pin screw	1	1	
43	93WF7-035	Spring	1	1	

8. Presser foot adjusting mechanism

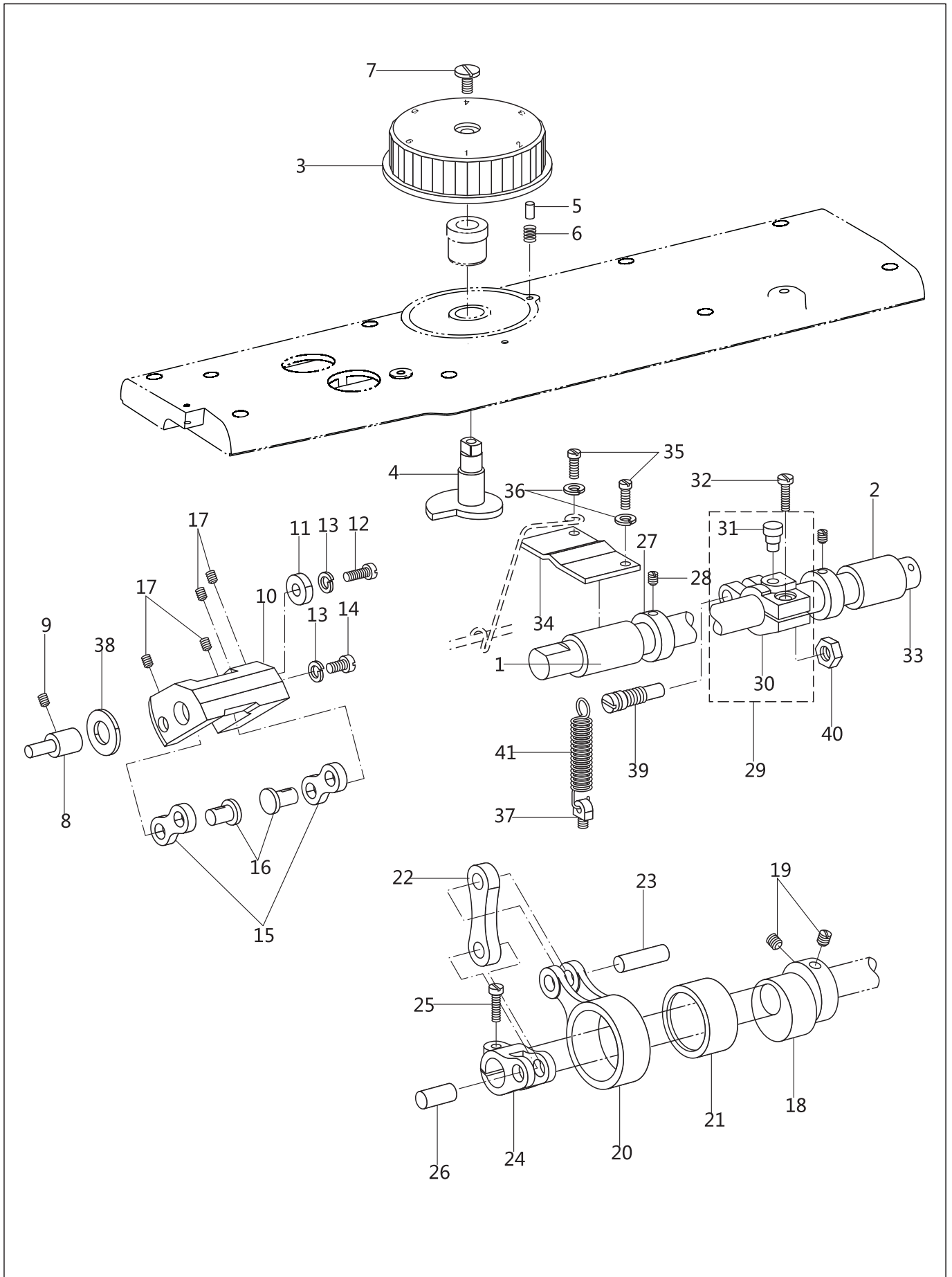

8. Presser foot adjusting mechanism

NO.	PARTS NO.	PARTS NAME	QTY		REMARK	
			TW 1- 898L14D2T5	TW 2- 898L14D2T5		
1	93WF8-005	Bushing, adjusting shaft	1	1	RAL7015	
2	93WF5-007	Bushing	1	1		
3	93WF8-0016A	Dial	1	1		
4	93WF8-006	Dial cam	1	1		
5	93WF8-007	Dial pin	1	1		
6	93WF8-002	Spring	1	1		
7	302395	Set screw	1	1		
8	93WF8-009	Support pin	1	1		
9	93WF5-030	Set screw	1	1		
10	93WF8-010	Adjusting bracket	1	1		
11	93WF8-011	Adjusting bracket collar	1	1	GB 859 5	
12	93WF1-026	Bolt	1	1		
13		Washer, spring	2	2		
14	93WF8-037	Bolt	1	1		
15	93WF8-013	Link assy.	2	2		
16	93WF7-028	Link pin	2	2		
17	93WF8-015	Set screw	4	4		
18	93WF8-016	Inner presser cam	1	1		
19	93WF1-027	Set screw	2	2		
20	93WF8-017	Link	1	1		
21	93WF8-018	Needle bearing	1	1	HK3016 30×37×16	
22	93WF8-019	Link	1	1		
23	93WF8-020	Pin	1	1		
24	93WF8-021	Connecting crank	1	1		
25	93WF6-042	Bolt	1	1		
26	93WF8-022	Pin	1	1		
27	93WF8-023	Collar	2	2	GB/T 80 M5×5	
28	93WF7-029	Set screw	2	2		
29	93WF8-025	Connecting lever assy.	1	1		
30	93WF8-025A	Connecting lever	1	1		
31	93WF8-025B	Pin	1	1		
32	93WF3-005	Bolt	1	1		
33	304WF8-001	Adjusting shaft	1	1		
34	93WF8-030	Support plate	1	1		
35	93WF8-031	Bolt	2	2		
36		Washer	2	2		GB 859 4
37	93WF8-003	Support screw	1	1		
38	93WF8-004	Felt	1	1		
39	93WF8-033	Spring hook	1	1		
40		Nut	1	1		GB/T 6172 M8
41	117WF8-001	Spring	1	1		

9. Alternating presser foot lifter mechanism

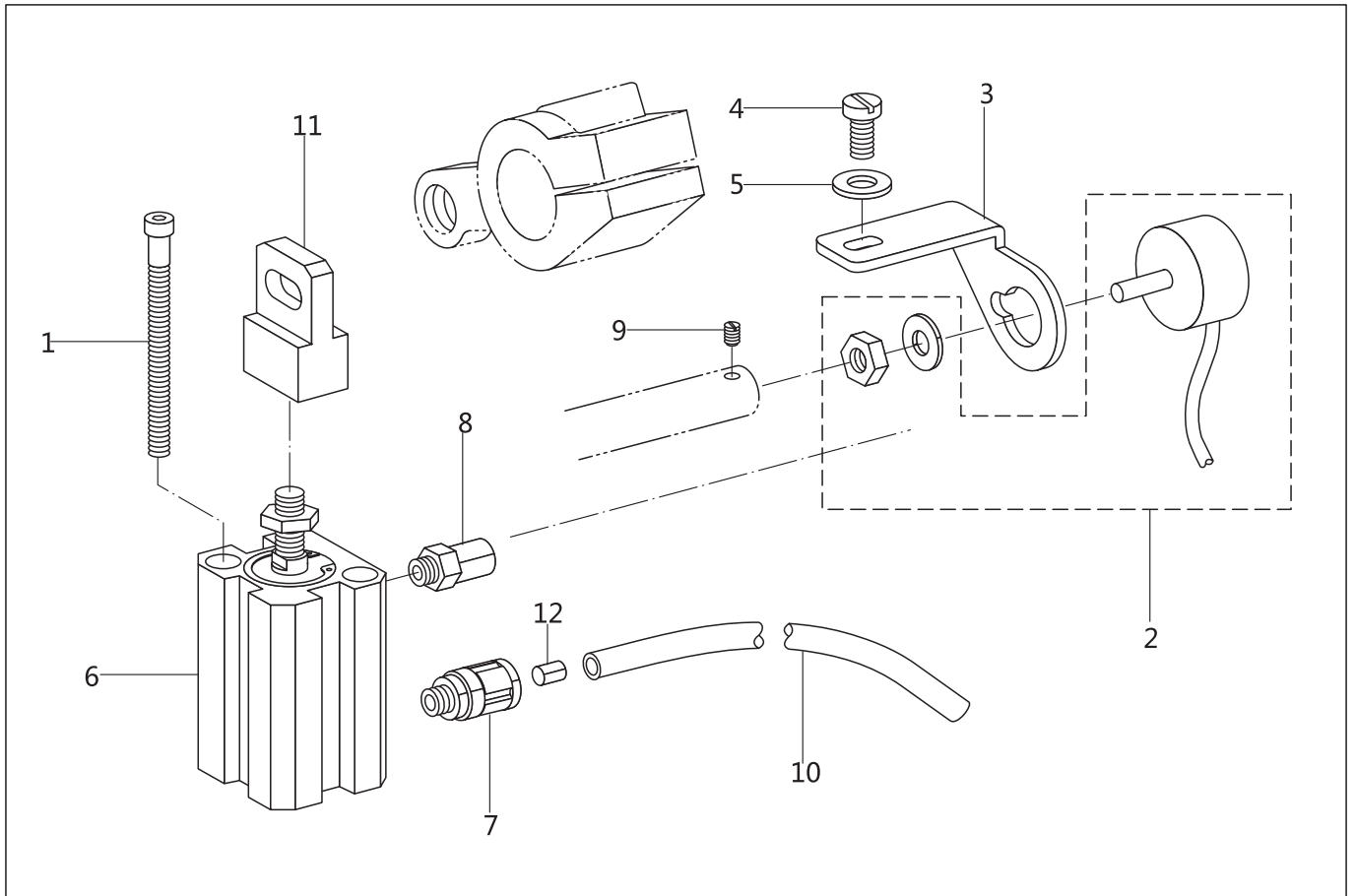

NO.	PARTS NO.	PARTS NAME	QTY		REMARK
			TW 1- 898L14D2T5	TW 2- 898L14D2T5	
1	93WF9-002	Bolt	2	2	
2	93WF9-003	Potentiometer assy.	1	1	
3	93WF9-001	Setting plate	1	1	
4		Bolt	1	1	GB/T 70.1 M4×6
5		Washer	1	1	GB/T 97.1 4
6	93WF9-004	Cylinder	1	1	SDA16×25
7	93WF7-008	Joint	1	1	ALP4-M5
8	93WF7-009	Silencer	2	2	BSL-M5
9		Set screw	1	1	GB/T 70.1 M3×45
10		Air tube	1	1	L=1000
11	93WF9-007	Knuckle	1	1	
12	93WF9-006	Copper tube	1	1	

10. Quick reverse mechanism

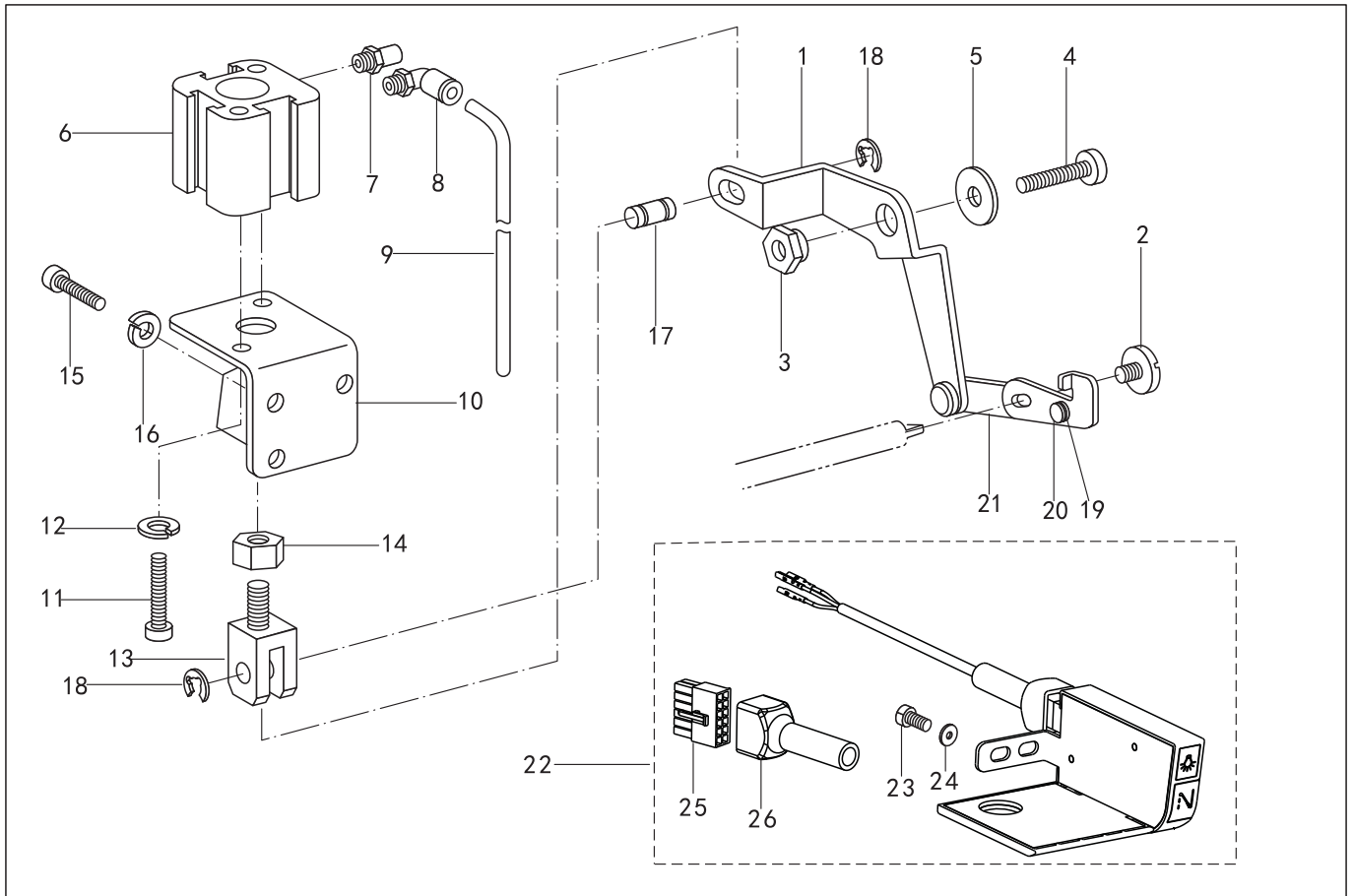

NO.	PARTS NO.	PARTS NAME	QTY		REMARK
			TW 1- 898L14D2T5	TW 2- 898L14D2T5	
1	93WF10-003	Cylinder connection assy.	1	1	
2	2KT3-005	Screw	1	1	
3	62WF5-025	Stud	1	1	
4	21WF2-048	Screw	1	1	
5	62WF5-026	Washer	1	1	
6	93WF10-004	Cylinder	1	1	SDA25×15 SU046
7	93WF7-009	Silencer	1	1	
8	93WF7-008	Joint	1	1	
9		Air tube, 4mm	1	1	L=840
10	93WF10-001	Setting plate	1	1	
11	93WF10-006	Bolt	2	2	
12		Washer, spring	2	2	GB 93. 6
13	93WF10-008	Knuckle	1	1	
14		Nut	1	1	GB/T6172 M6
15	93WF7-014	Bolt	3	3	
16		Washer, spring	3	3	GB/T 859 5
17	93WF10-002	Coupling pin	1	1	
18		Retaining ring	2	2	GB/T 896 4
19	62WF5-024D	Nylon washer	2	2	
20	62WF5-024C	Pin	2	2	
21	62WF5-024B	Link rod, reverse stitching lever	1	1	
22	394WF10-002	Reverse switch assy.	1	1	
23		Screw	2	2	GB/T 70. 2 M4X8
24		Washer	2	2	GB/T 97. 1 4
25	356WF4-002	Connector	1	1	
26	356WF4-003	Cover	1	1	RAL7015

11. Upper feed mechanism

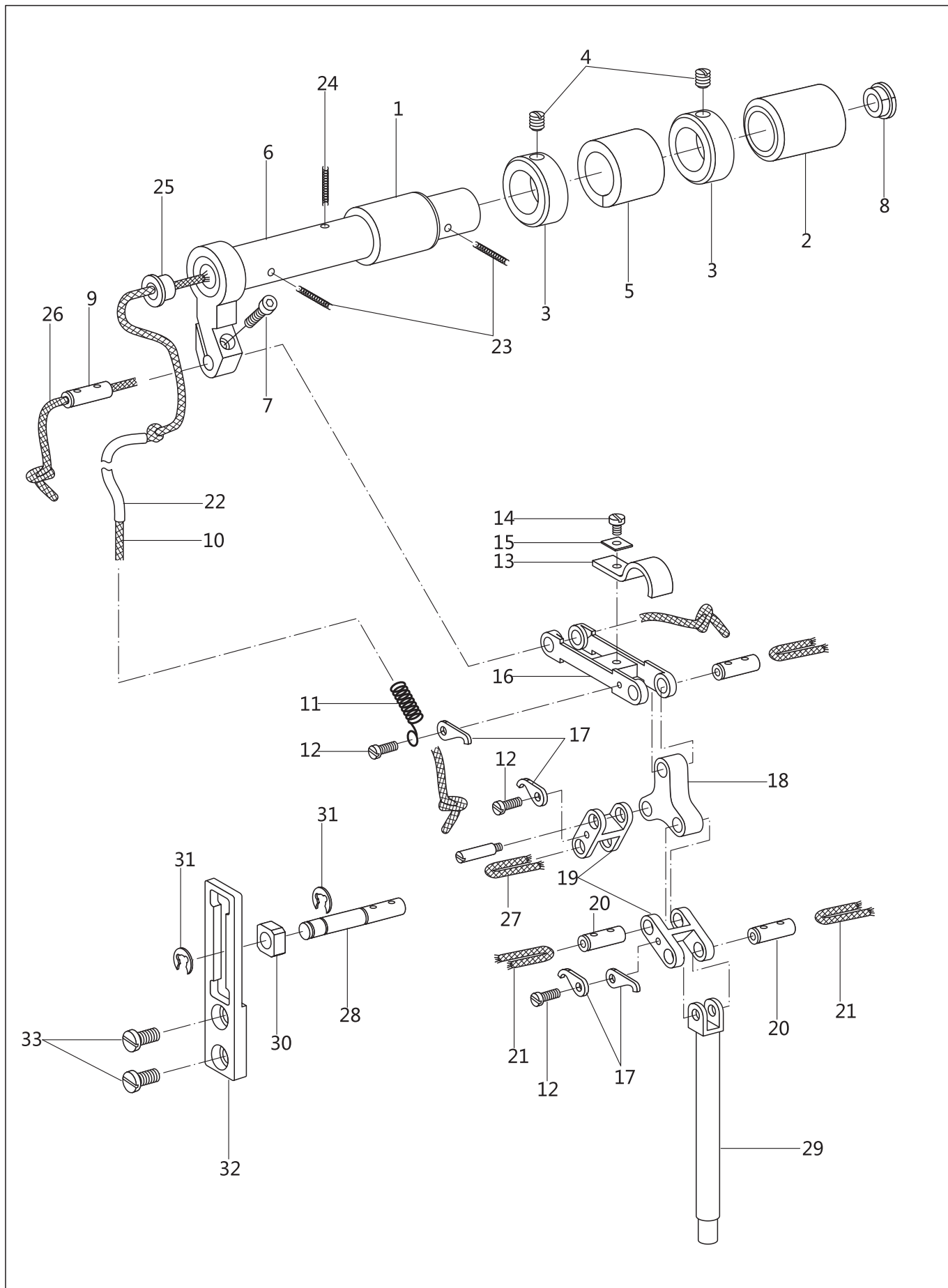

11. Upper feed mechanism

NO.	PARTS NO.	PARTS NAME	QTY		REMARK
			TW 1- 898L14D2T5	TW 2- 898L14D2T5	
1	93WF5-007	Bushing, F	1	1	
2	93WF11-001	Bushing, B	1	1	
3	93WF8-023	Collar	2	2	
4	93WF7-029	Set screw	2	2	
5	93WF11-002	Sponge	1	1	
6	93WF11-008	Shaft assy.	1	1	
7	93WF8-031	Bolt	1	1	
8	93WF11-003	Rubber cap	1	1	
9	93WF11-009	Connecting pin	1	1	
10		Oil wick	1	1	L = 235
11	93WF11-010	Tube guide	1	1	
12	93WF11-011	Bolt	3	3	
13	93WF11-004	Leather	1	1	
14	93WF8-036	Bolt	1	1	
15	93WF11-013	Washer	1	1	
16	93WF11-014	Connection	1	1	
17	93WF11-005	Stopper claw	4	4	
18	93WF11-015	Presser connection plate	1	1	
19	93WF11-016	Presser bar connection	2	2	
20	93WF11-009	Connection pin	3	3	
21		Oil wick	1	1	L = 50
22		Oil tube	1	1	L = 75
23		Oil wick	1	1	L = 75
24		Felt	1	1	L = 20
25	93WF3-010	Rubber cap	1	1	
26		Oil wick	1	1	L = 80
27		Oil wick	1	1	
28	93WF11-019	Inner presser bar	1	1	
29	93WF11-020	Presser bar	1	1	
30	93WF11-021	Slide block	1	1	
31	93WF11-006	Retaining ring	2	2	
32	93WF11-022	Steady plate	1	1	
33	13WF7-015	Screw	2	2	

12. Feed shaft mechanism

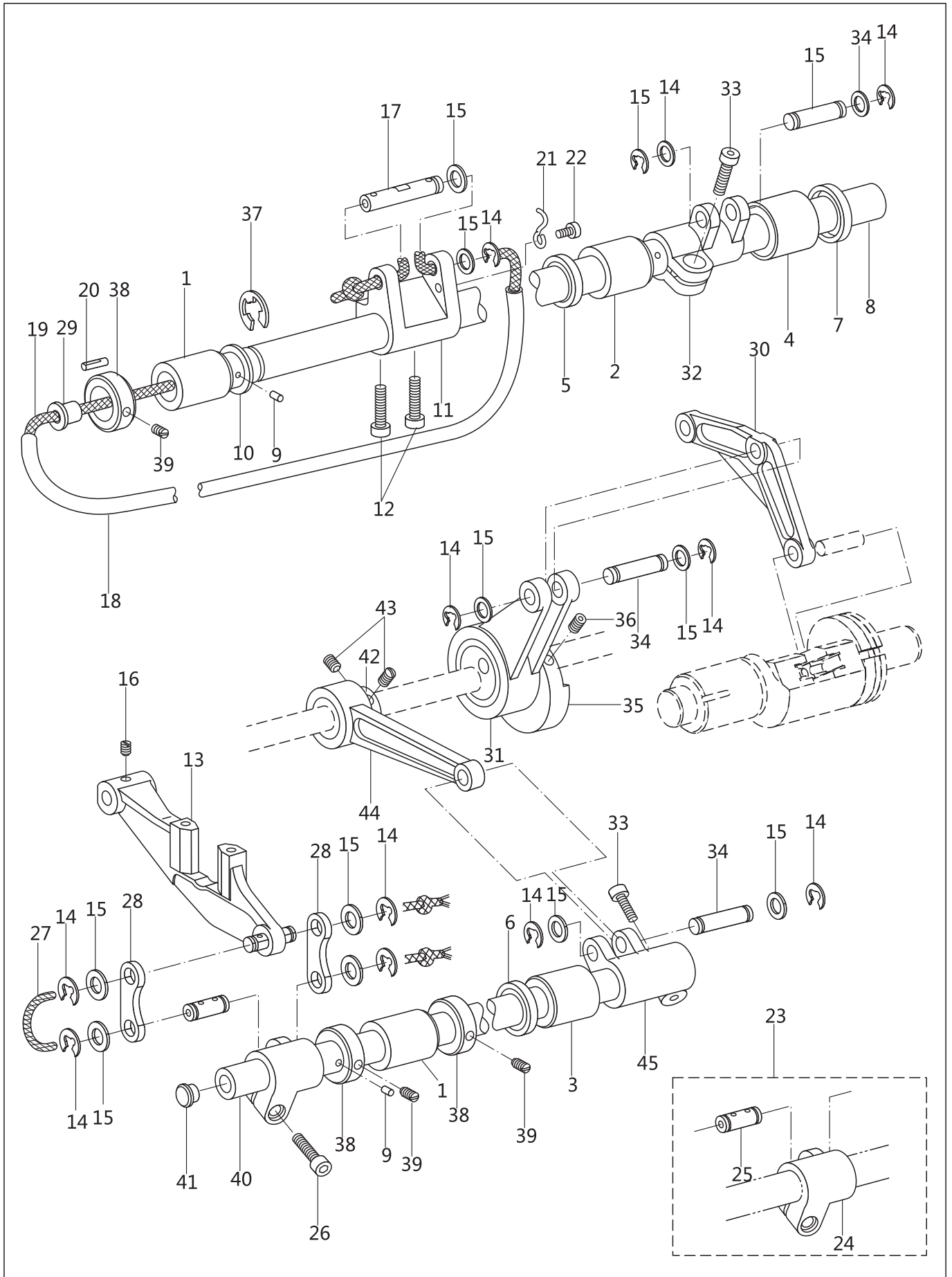

12. Feed shaft mechanism

NO.	PARTS NO.	PARTS NAME	QTY		REMARK
			TW 1- 898L14D2T5	TW 2- 898L14D2T5	
1	93WF5-007	Feed shaft bushing, F	2	2	
2	93WF12-001	Feed shaft bushing, M	1	1	
3	93WF12-002	Bushing, F	1	1	
4	93WF12-003	Feed shaft bushing	1	1	
5	93WF12-008	Oil seal	1	1	15×24×7
6	93WF12-008	Oil seal	1	1	15×24×7
7	93WF12-010	Oil seal	1	1	15×24×7
8	304WF12-001	Feed shaft	1	1	
9		Felt	2	2	
10	93WF12-004	Ring	1	1	
11	93WF12-012	Feed arm	1	1	
12	93WF10-006	Bolt	2	2	
13	93WF12-013	Feed bracket assy.	1	1	
14	266097	Retaining ring	11	11	
15	93WF12-005	Washer	12	12	
16	93WF12-035	Set screw	1	1	
17	93WF12-015	Pin	1	1	
18		Oil tube	1	1	L=200
19		Oil wick	1	1	L=300
20		Felt	1	1	3×18
21	93WF12-006	Tube holder	1	1	
22		Bolt	1	1	GB/T 70.1 M4×6
23	93WF12-016	Feed connection arm assy.	1	1	
24	93WF12-017A	Feed connection arm	1	1	
25	93WF12-018B	Pin	1	1	
26	93WF12-019	Bolt	1	1	
27		Oil wick	1	1	L=110
28	93WF12-020	Feed link assy.	2	2	
29	93WF3-010	Rubber cap	1	1	
30	93WF12-022	Back cylinder connection	1	1	
31	93WF12-023	Connection rod assy., L-feed	1	1	
32	93WF12-034	Feed shaft arm	1	1	
33	93WF7-012	Bolt	2	2	
34	93WF12-026	Pin	3	3	
35	93WF12-027	Lower feed cam	1	1	
36	93WF1-027	Set screw	2	2	
37	93WF12-007	Retaining ring	1	1	
38	93WF8-023	Collar, adjust shaft	3	3	
39	93WF7-029	Set screw	3	3	
40	304WF12-002	Adjust-shaft	1	1	
41	93WF11-003	Rubber cap	1	1	
42	93WF12-031	Feed cam	1	1	
43	93WF2-008	Set screw	2	2	
44	93WF12-033	Feed rod	1	1	
45	93WF12-034	Feed shaft arm	1	1	

13. Motor mechanism

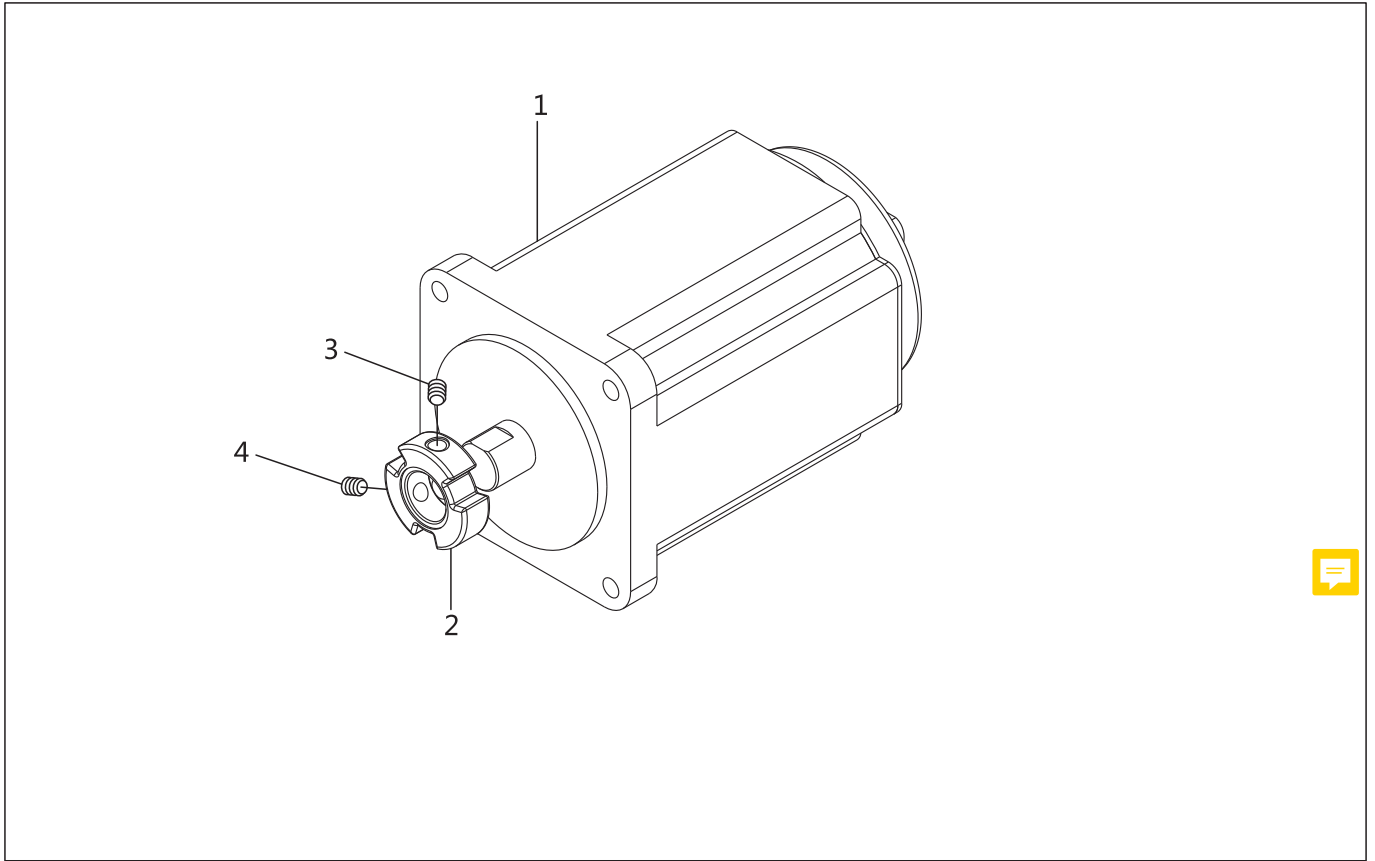

NO.	PARTS NO.	PARTS NAME	QTY		REMARK
			TW 1- 898L14D2T5	TW 2- 898L14D2T5	
1	394WF2-003	Motor	1	1	
2	394WF2-001B	Coupling assy.	1	1	
3	394WF2-006	Screw	1	1	
4	93WF15-012	Screw	1	1	

14. Needle plate, presser foot

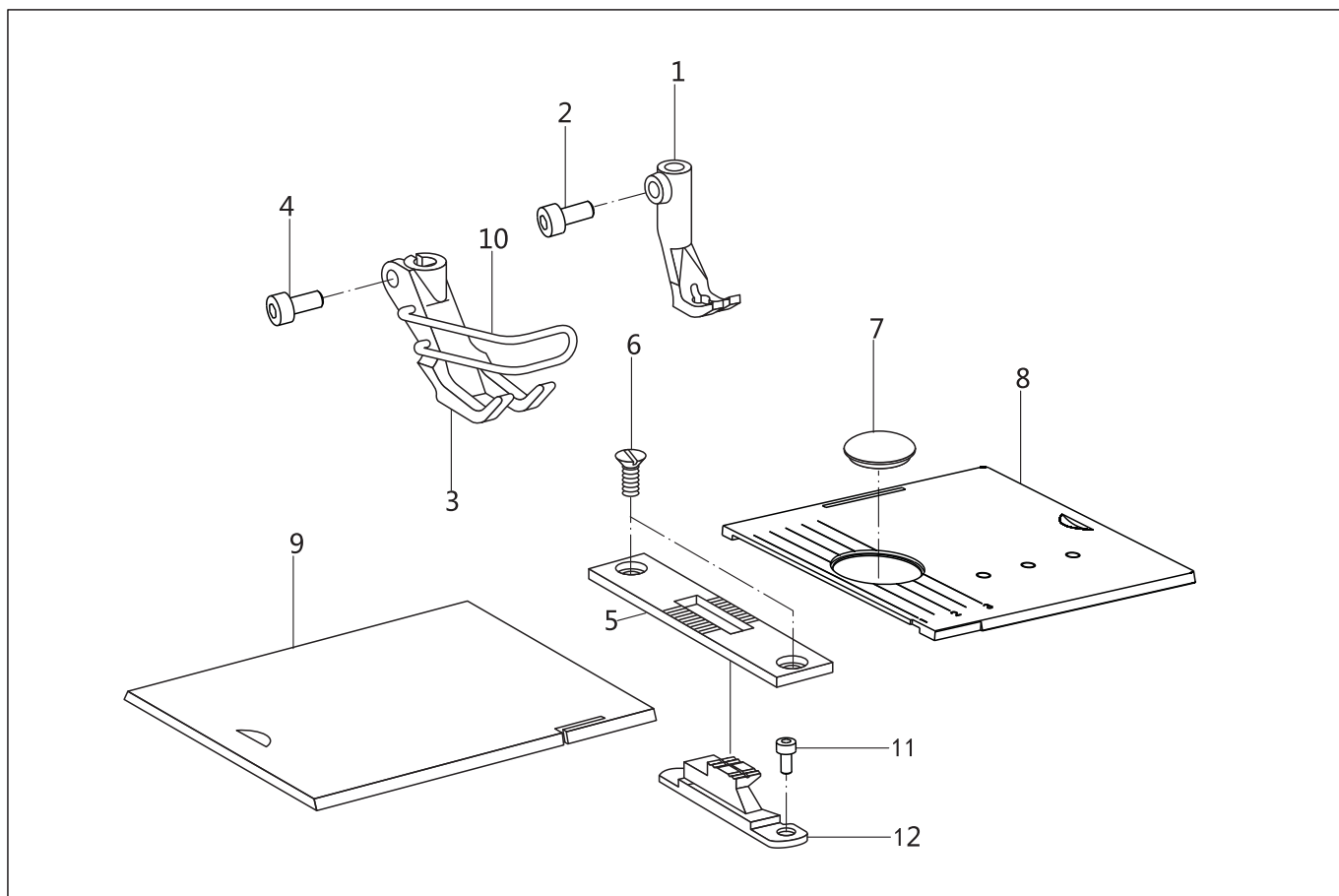

NO.	PARTS NO.	PARTS NAME	QTY	REMARK
			TW1-898L14D2T5	
1	93WF13-003	Walking foot	1	
2	93WF13-004	Bolt	1	
3	93WF13-005	Presser foot	1	
4	93WF13-006	Bolt	1	
5	93WF13-007	Needle plate	1	
6	93WF13-001	Screw	2	
7	21WF4-059	Bobbin window	1	
8	93WF13-008	Slide plate, R	1	
9	93WF13-009	Slide plate, L	1	
10	93WF13-011	Finger guard	1	
11	93WF13-002	Screw	2	
12	93WF13-012	Feed dog	1	

14. Needle plate, presser foot (2-needle machine)

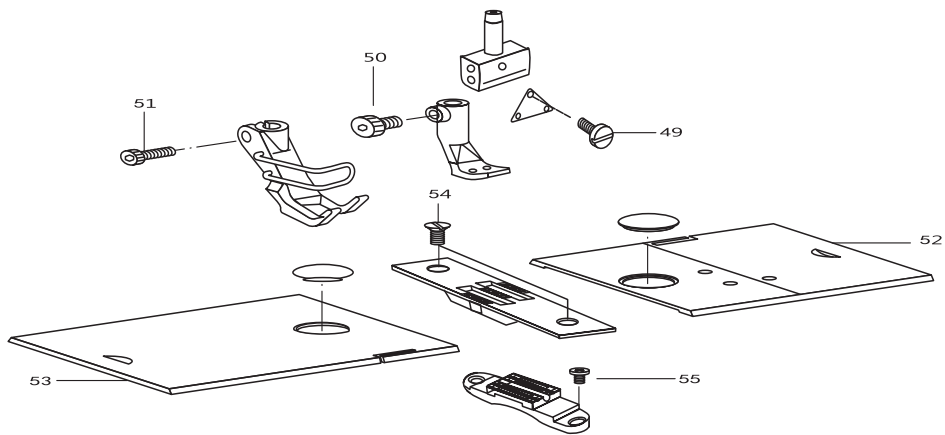
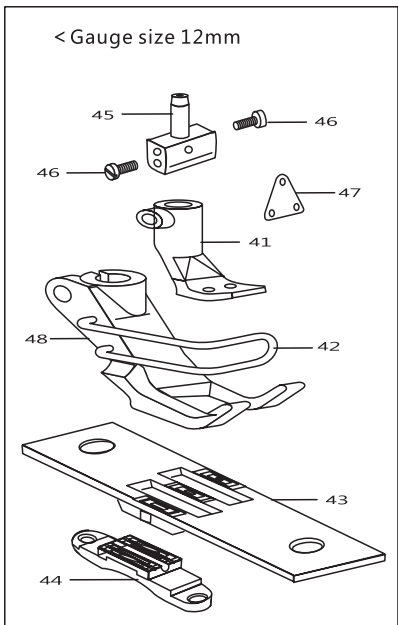
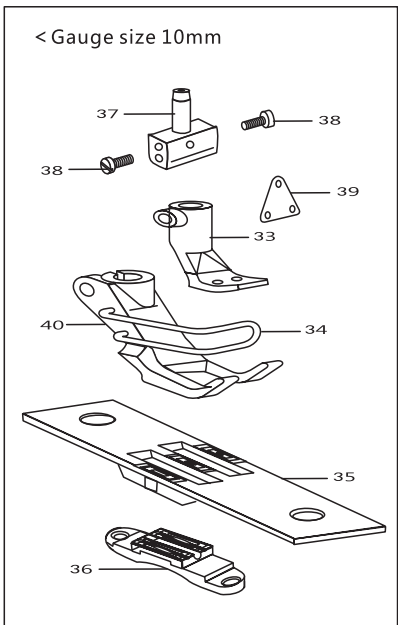
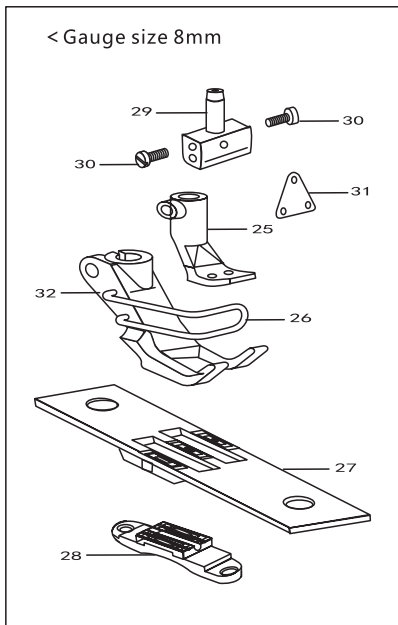
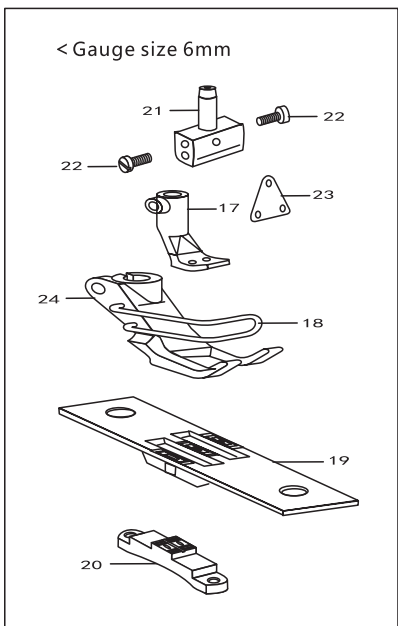
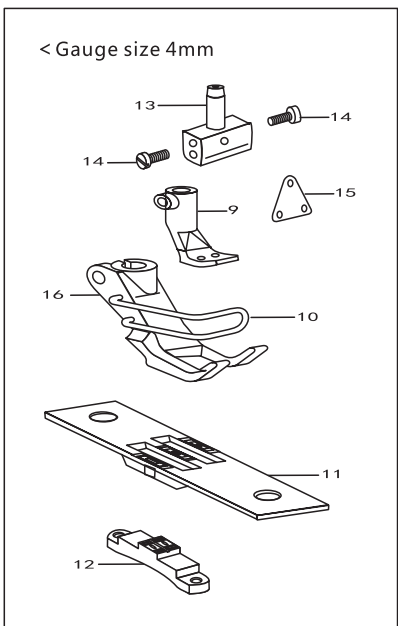
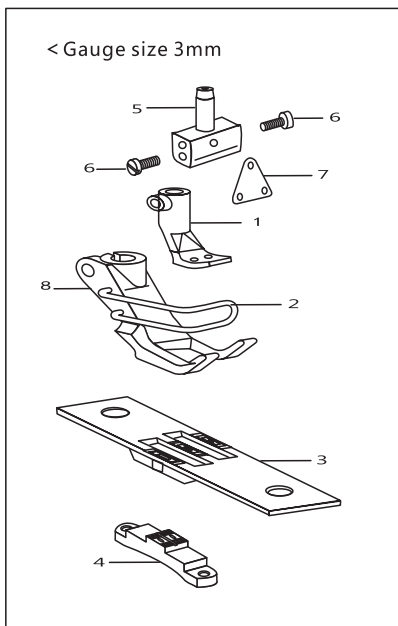

14. Needle plate, presser foot (2–needle machine)

NO.	PARTS NO.	PARTS NAME	QTY	REMARK
1	193WF13-001a	Inner presser foot (3)	1	
2	193WF13-006a	Finger guard	1	
3	193WF13-003a	Needle plate (3)	1	
4	193WF13-005a	Feed dog (3)	1	
5	193WF5-001a	Needle clamp (3)	1	
6	179WF5-004	Screw	2	
7	193WF5-002a	Thread guide	1	
8	193WF13-002a	Walking foot (3–4)	1	
9	193WF13-001b	Innder presser foot (4)	1	
10	193WF13-006a	Finger guard	1	
11	193WF13-003b	Needle plate	1	
12	193WF13-005b	Feed dog (4)	1	
13	193WF5-001b	Needle clamp (4)	1	
14	179WF5-004	Screw (4)	2	
15	193WF5-002a	Thread guide	1	
16	193WF13-002a	Walking foot (3–4)	1	
17	193WF13-001c	Inner foot (6)	1	
18	193WF13-006a	Finger guard	1	
19	193WF13-003c	Needle plate (6)	1	
20	193WF13-005c	Feed dog (6)	1	
21	193WF5-001c	Needle clamp (6)	1	
22	179WF5-004	Screw	2	
23	193WF5-002a	Thread guide	1	
24	193WF13-002b	Walking foot (6)	1	
25	193WF13-001d	Inner foot (8)	1	
26	193WF13-006b	Finger guard	1	
27	193WF13-003d	Needle plate (8)	1	
28	193WF13-005d	Feed dog (8)	1	
29	193WF5-001d	Needle clamp (8)	1	
30	179WF5-004	Screw	2	
31	193WF5-002b	Thread guide	1	
32	193WF13-002c	Inner foot (10)	1	
33	193WF13-001e	Finger guard	1	
34	193WF13-006b	Needle plate (10)	1	
35	193WF13-003e	Feed dog (10)	1	
36	193WF13-005e	Needle clamp (10)	1	
37	193WF5-001d	Screw	1	
38	179WF5-004	Thread guide	2	
39	193WF5-002a	Walking foot (10)	1	
40	193WF13-002c	Inner foot (12)	1	
41	193WF13-001f	Finger guard	1	
42	193WF13-006b	Needle plate (12)	1	
43	193WF13-003f	Feed dog (12)	1	
44	193WF13-005f	Needle clamp (12)	1	
45	193WF5-001f	Screw	1	
46	179WF5-004	Thread guide	2	
47	193WF5-002b	Walking foot (12)	1	
48	193WF13-002e	Screw	1	
49	16WF1-006	Screw	1	
50	93WF13-004	Screw	1	
51	93WF13-006	Sliding plate (R)	1	
52	93WF13-008	Window plate	1	
53	193WF13-004	Sliding plate (L)	1	
54	93WF13-001	Screw	2	
55	93WF13-002	Screw	2	

15. Rotary hook shaft timing mechanism

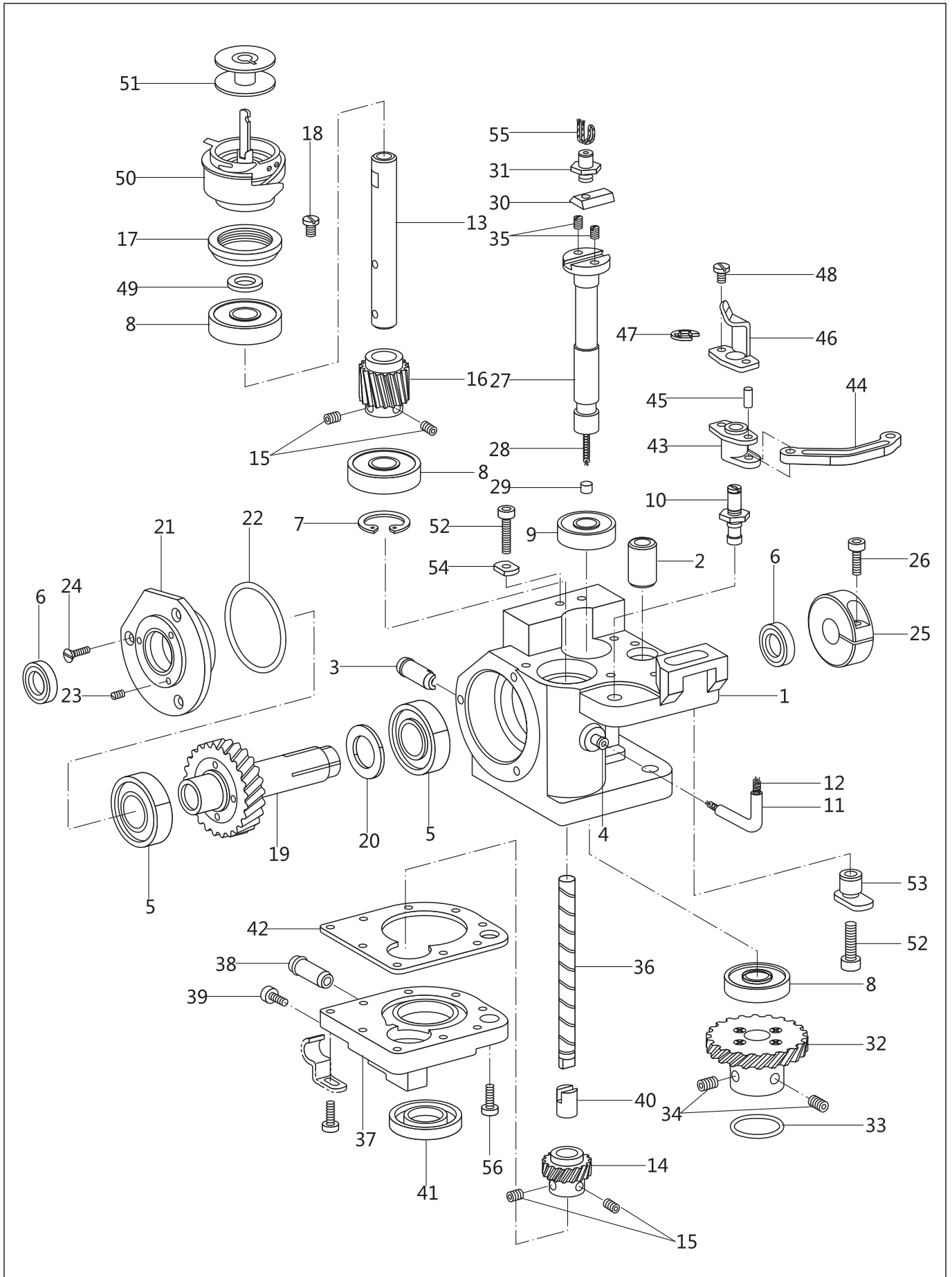

15. Rotary hook shaft timing mechanism

NO.	PARTS NO.	PARTS NAME	QTY		REMARK
			TW 1- 898L14D2T5	TW 2- 898L14D2T5	
1	93WF14-012	Hook saddle (R)	1	1	
2	93WF14-013	Bushing	1	1	
3	93WF14-001	Drain pipe	1	1	
4	93WF3-001	Pipe	1	1	
5	93WF14-014	Ball bearing	2	2	16002 15×32×8
6	93WF14-015	Oil seal	2	2	15×21×3
7		Retaining ring	1	1	GB893.1 26
8	93WF14-017	Ball bearing	3	3	6000 10×26×8
9	193WF14-047	Bearing	1	1	2080900 10X22X6
10	93WF14-019	Pin	1	1	
11		Oil tube	1	1	L=35
12		Oil wick	1	1	L=40
13	93WF14-020	Shaft, rotary hook	1	1	
14	93WF14-002	Gear, OP-shaft	1	1	
15	93WF7-029	Set screw	4	4	
16	93WF14-003	Gear	1	1	
17	93WF14-021	Supporter	1	1	
18	496512	Screw	2	2	
19	93WF14-047	Gear assy.	1	1	
20	93WF14-023	Washer	1	1	
21	93WF14-046	Lower shaft holder	1	1	
22	93WF14-005	O ring	1	1	
23		Set screw	3	3	GB/T 77 M4×5
24		Screw	3	3	GBT/68 M4×6
25	93WF14-025	Collar	1	1	
26	93WF3-005	Bolt	1	1	
27	93WF14-026	Opener shaft	1	1	
28		Oil wick	1	1	L=80
29	93WF14-006	Rubber cap, 4.2mm	1	1	
30	93WF14-027	Adjusting guide rail	1	1	
31	93WF14-007	Adjusting pin	1	1	
32	93WF14-048	Gear assy.	1	1	
33	33T2-30-A	O ring	1	1	
34	93WF8-015	Set screw	2	2	
35	93WF14-030	Set screw	2	2	
36	93WF14-031	Lubrication shaft	1	1	
37	93WF14-032	Oil tank, hook base	1	1	
38	93WF1-017	Pipe	1	1	
39	93WF8-036	Bolt	1	1	
40	93WF14-033	Bushing	1	1	
41	93WF14-034	Oil seal	1	1	22×32×7
42	93WF14-008	Sheet packing	1	1	
43	93WF14-035	Setting bracket, opener	1	1	
44	93WF14-036	Opener arm	1	1	
45	93WF14-037	Pin	1	1	
46	93WF14-038	Opener	1	1	
47	93WF14-009	Retaining ring, 4mm	1	1	
48	13WF1-015	Screw	2	2	
49	93WF14-040	Washer	1	1	t1=0.3/t2=0.4/t3=0.5/t4=0.2
50	93WF14-041	Rotary hook assy.	1	1	
51	93WF14-042	Bobbin	1	1	
52	93WF14-043	Bolt	2	2	
53	93WF14-044	Eccentric collar	1	1	
54	93WF14-045	Washer	1	1	
55		Oil wick	1	1	L=50
56	93WF13-006	Bolt	9	9	

15. Rotary hook shaft timing mechanism(2-needle machine)

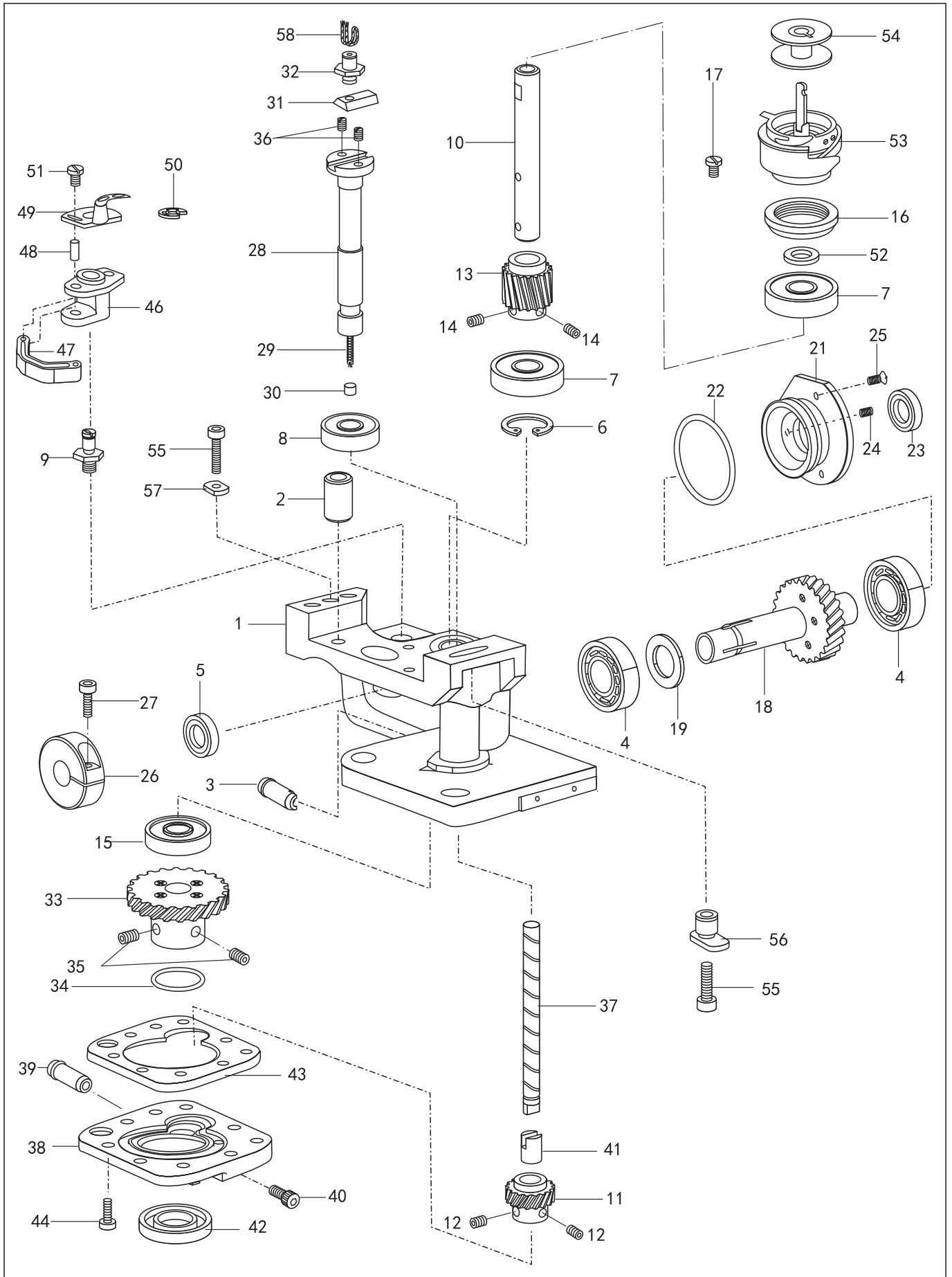

15. Rotary hook shaft timing mechanism(2-needle machine)

NO.	PARTS NO.	PARTS NAME	QTY	REMARK
			TW2-898L14D2T5	
1	193WF14-001	Hook saddle (L)	1	
2	93WF14-013	Bushing	1	
3	93WF14-001	Drain pipe	1	
4	93WF14-014	Ball bearing	2	16002 15×32×8
5	93WF14-015	Oil seal	1	15×21×3
6		Retaining ring	2	GB893.1 26
7	93WF14-017	Ball bearing	2	6000 10×26×8
8	193WF14-047	Bearing	1	2080900 10×22×6
9	193WF14-003	Pin	1	
10	93WF14-020	Shaft, rotary hook	1	
11	93WF14-002	Gear, OP-shaft	1	
12	93WF8-015	Set screw	2	
13	93WF14-003	Gear	1	
14	93WF7-029	Set screw	2	
15	193WF14-048	Bearing	1	6000 10×26×6
16	93WF14-021	Supporter	1	
17	496512	Screw	2	
18	93WF14-047	Gear assy.	1	
19	93WF14-023	Washer	1	
20				
21	93WF14-046	Lower shaft holder	1	
22	93WF14-005	O ring	1	
23	93WF14-015	Oil seal	1	15×21×3
24		Set screw	3	GB/T77 M4×5
25		Screw	3	GB/T68 M4×4
26	93WF14-025	Collar	1	
27	93WF3-005	Bolt	1	
28	93WF14-026	Opener shaft	1	
29		Oil wick	1	L=80
30	93WF14-006	Rubber cap, 4.2mm	1	
31	93WF14-027	Adjusting guide rail	1	
32	93WF14-028	Adjusting pin	1	
33	93WF14-048	Gear assy.	1	
34	33T2-030-A	O ring	1	
35	93WF8-015	Set screw	2	
36	93WF14-030	Set screw	2	
37	93WF14-031	Lubrication shaft	1	
38	193WF14-002	Oil tank, hook base	1	
39	93WF14-001	Pipe	1	
40	93WF8-036	Bolt	1	
41	93WF14-033	Bushing	1	
42	93WF14-034	Oil seal	1	22×32×7
43	93WF14-008	Sheet packing	1	
44	93WF13-006	Bolt	9	
45				
46	93WF14-035	Setting bracket, opener	1	
47	93WF14-036	Opener arm	1	
48	93WF14-037	Pin	1	
49	93WF14-038	Opener	1	
50	93WF14-009	Retaining ring	1	
51	13WF1-015	Screw	2	
52	93WF14-040	Washer	1	t1=0.3/t2=0.4/t3=0.5/t4=0.2
53	93WF14-041	Rotary hook assy.	1	
54	93WF14-042	Bobbin	1	
55	93WF14-043	Bolt	2	
56	93WF14-044	Eccentric collar	1	
57	93WF14-045	Washer	1	
58		Oil wick	1	L=50

16. Lower shaft mechanism

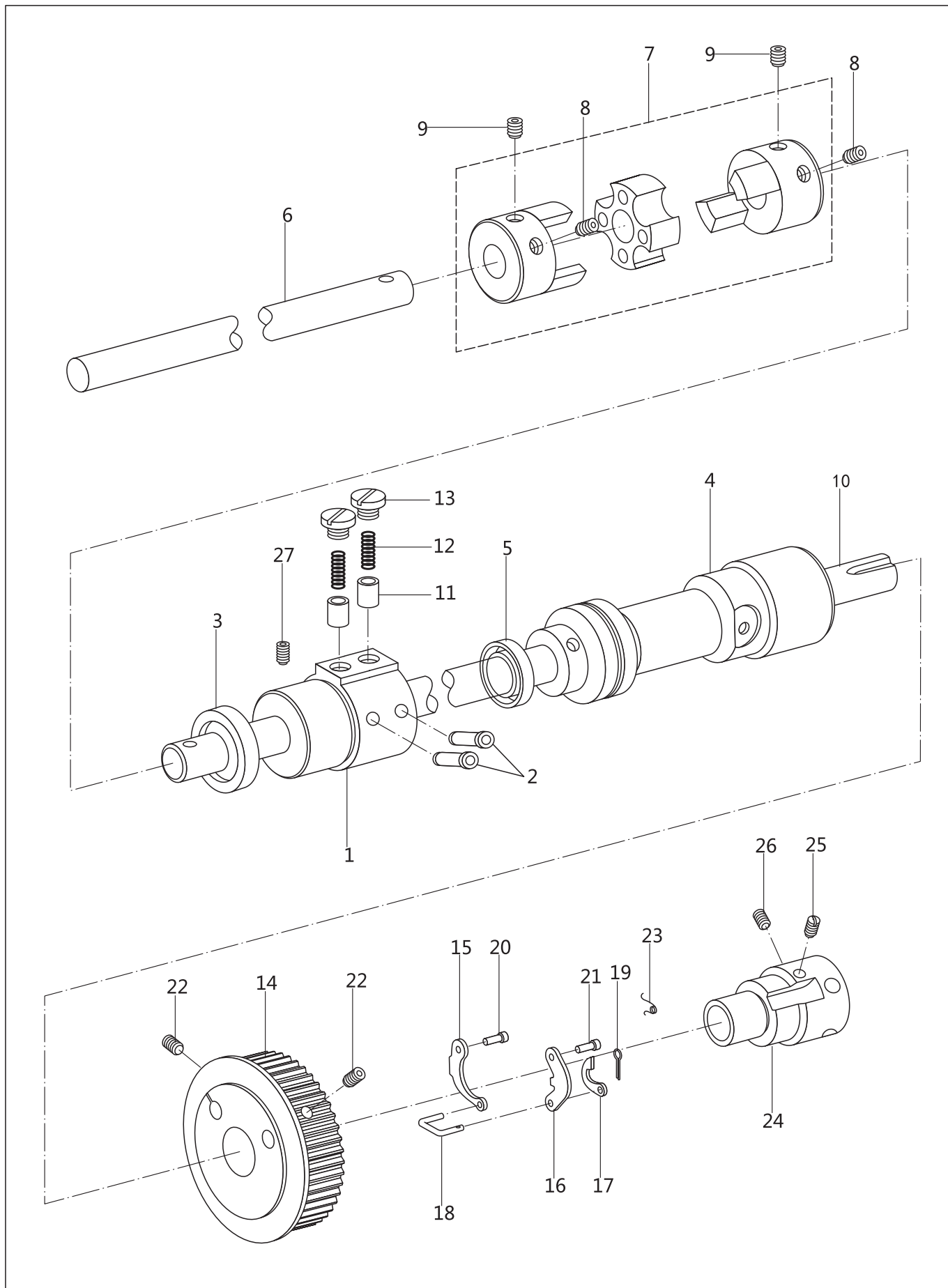

16. Lower shaft mechanism

NO.	PARTS NO.	PARTS NAME	QTY		REMARK
			TW 1- 898L14D2T5	TW 2- 898L14D2T5	
1	93WF15-006A	Bushing, F; L-shaft	1	1	
2	93WF3-001	Pipe	3	3	
3	93WF15-007	Oil seal	1	1	12×30×7
4	93WF15-008	Bushing, B; L-shaft	1	1	
5	93WF15-009	Oil seal	1	1	12×22×7
6	304WF15-001	Lower shaft	1	—	
	318WF15-001	Lower shaft	—	1	
7	93WF15-001	Lower shaft coupling assy.	1	1	
8	93WF15-011	Screw	2	2	
9	93WF15-012	Screw	2	2	
10	93WF15-013A	Lower shaft, B	1	1	
11	93WF15-002	Plunge	2	2	
12	93WF15-003	Spring, compression	2	2	
13	93WF15-004	Screw	2	2	
14	93WF15-005	Belt pulley assy., Lower	1	1	
15	22WF1-013	Spring, lock lever	1	1	
16	22WF1-018	Lock lever	1	1	
17	22WF1-016	Rachet	1	1	
18	22WF1-017	Connecting link	1	1	
19		Pin	1	1	GB/T 91 1.2×8
20	22WF1-015	Lock lever shaft	1	1	
21	22WF1-019	Shaft, spring	1	1	
22	93WF8-015	Set screw	2	2	
23	22WF1-014	Spring	1	1	
24	93WF15-015	Bushing	1	1	
25	93WF15-016	Set screw	1	1	
26	93WF15-017	Set screw	1	1	
27	93WF2-015	Set screw	1	1	

17. Lubrication mechanism

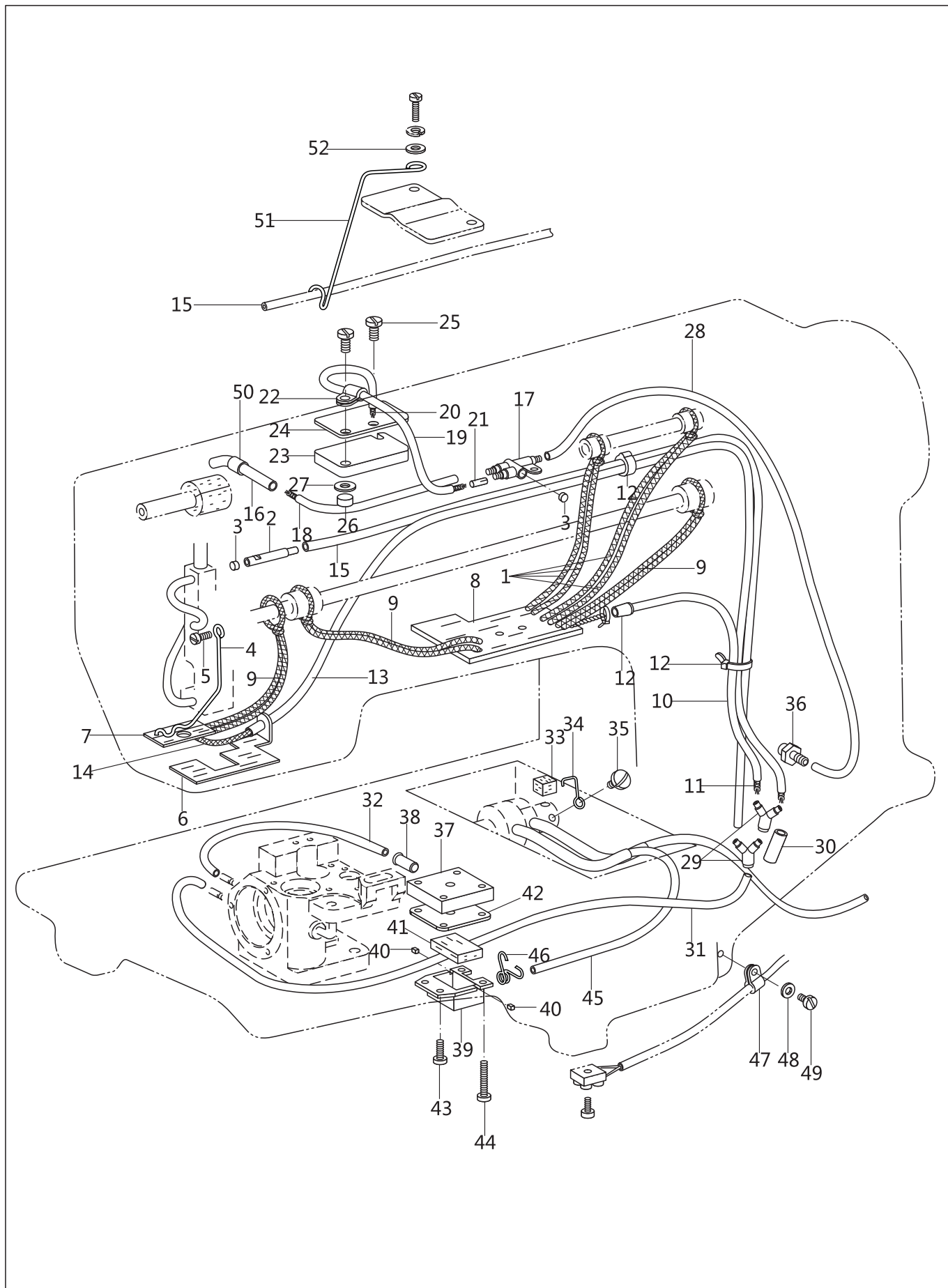

17. Lubrication mechanism

NO.	PARTS NO.	PARTS NAME	QTY		REMARK
			TW 1- 898L14D2T5	TW 2- 898L14D2T5	
1		Oil wick	2	2	L=400
2	93WF16-018	Oil tube	1	1	
3	93WF14-006	Rubber cap, 4.2mm	2	2	
4	93WF16-019	Oil wick support	1	1	
5	93WF8-037	Bolt	1	1	
6	93WF16-001	Felt	1	1	
7	93WF16-002	Felt	1	1	
8	93WF16-003	Felt	1	1	
9		Oil wick	3	3	L=400
10		Oil tube	1	1	L=200
11		Oil wick	1	1	L=250
12		Tube tie	3	3	3×110
13		Oil tube	1	1	L=490
14		Oil wick	1	1	L=620
15		Oil tube	1	1	L=480
16	93WF16-004	Pipe	1	1	
17	21WF7-016	Joint	1	1	
18		Oil tube	1	1	L=185
19		Oil tube	1	1	L=150
20		Oil wick	1	1	L=220
21		Felt	1	1	3×25
22	93WF16-021	Tube clamp	1	1	
23	93WF16-005	Felt	1	1	
24	93WF16-026	Felt support	1	1	
25	13WF7-015	Screw	1	1	
26	93WF16-006	Collar	1	1	
27	375290	Washer	1	1	
28		Oil tube	1	1	L=380
29	93WF16-007	Y-joint	2	2	
30		Oil tube	1	1	L=40
31		Oil tube	1	1	L=400
32		Oil tube	1	1	L=190
33	93WF16-008	Sponge	1	1	
34	93WF16-009	Sponge support	1	1	
35	999055	Screw	1	1	
36	93WF16-010	Oil feed pipe	1	1	
37	93WF16-024	Plate, filter bracket	1	1	
38	93WF1-017	Pipe	2	2	
39	93WF16-011	Sub-tank	1	1	
40	93WF16-012	Rubber cap	2	2	
41	93WF16-013	Felt	1	1	
42	93WF16-014	Packing	1	1	
43	33T3-007	Screw	3	3	
44	93WF16-015	Screw	2	2	
45		Oil tube	1	1	L=450
46	21WF7-006	Tube clip	1	1	
47	93WF16-016	Cushion clamp	1	1	
48	93WF1-009	Washer	1	1	
49	93WF16-025	Screw	1	1	
50		Oil tube	1	1	L=5
51	93WF16-017	Tube support	1	1	
52		Washer	1	1	GB/T 97.1 4

17. Lubrication mechanism(2-needle machine)

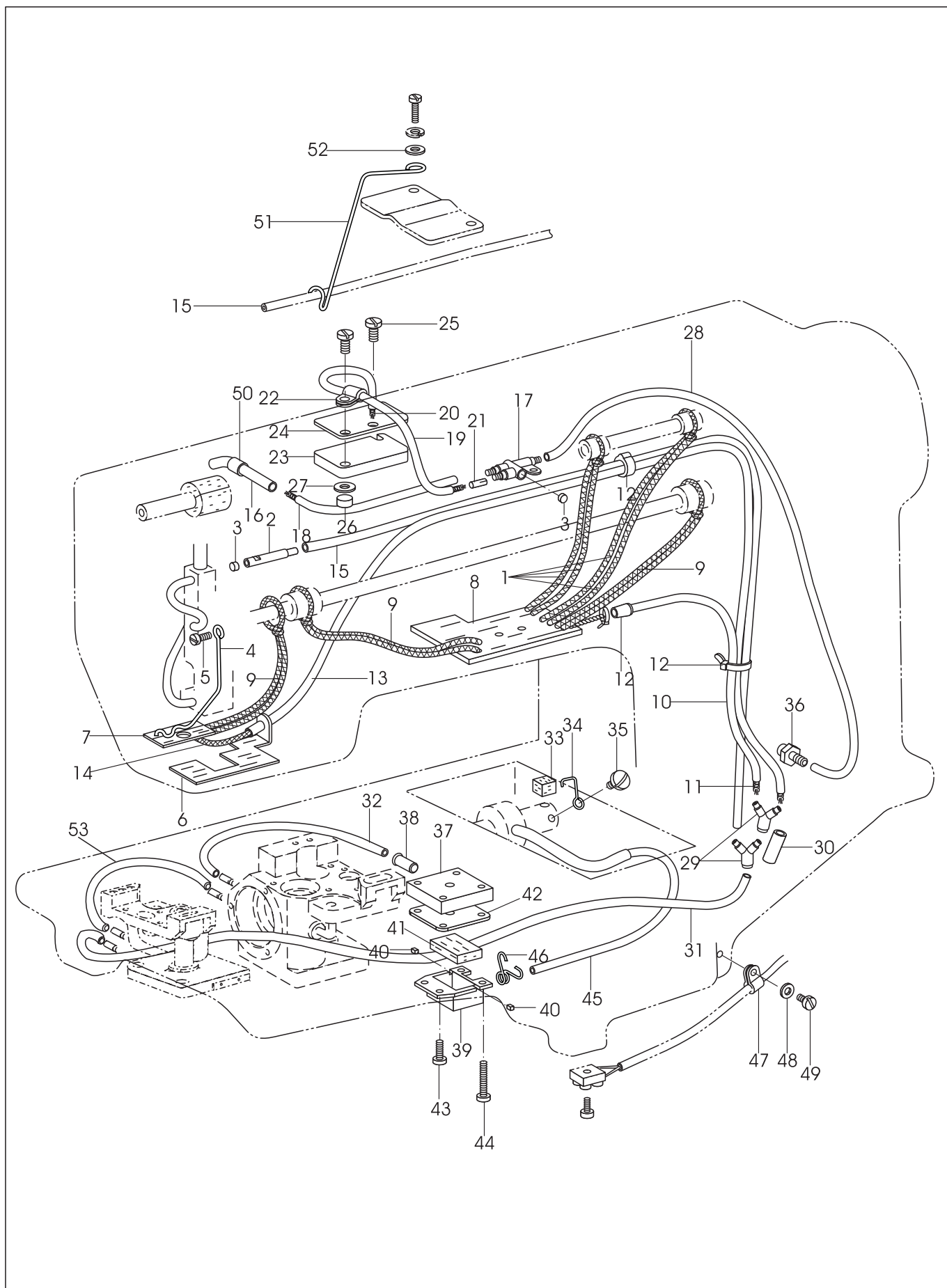

17. Lubrication mechanism(2-needle machine)

NO.	PARTS NO.	PARTS NAME	QTY	REMARK
			TW2-898L14D2T5	
1		Oil wick	2	L=400
2	93WF16-018	Oil tube	1	
3	93WF14-006	Rubber cap, 4.2mm	2	
4	93WF16-019	Oil wick support	1	
5	93WF8-037	Bolt	1	
6	93WF16-001	Felt	1	
7	93WF16-002	Felt	1	
8	93WF16-003	Felt	1	
9		Oil wick	3	L=400
10		Oil tube	1	L=200
11		Oil wick	1	L=250
12		Tube tie	3	3×110
13		Oil tube	1	L=490
14		Oil wick	1	L=620
15		Oil tube	1	L=480
16	93WF16-004	Pipe	1	
17	21WF7-016	Joint	1	
18		Oil tube	1	L=185
19		Oil tube	1	L=150
20		Oil wick	1	L=220
21		Felt	1	3×25
22	93WF16-021	Tube clamp	1	
23	93WF16-005	Felt	1	
24	93WF16-026	Felt support	1	
25	13WF7-015	Screw	1	
26	93WF16-006	Collar	1	
27	375290	Washer	1	
28		Oil tube	1	L=380
29	93WF16-007	Y-joint	2	
30		Oil tube	1	L=40
31		Oil tube	1	L=400
32		Oil tube	1	L=190
33	93WF16-008	Sponge	1	
34	93WF16-009	Sponge support	1	
35	999055	Screw	1	
36	93WF16-010	Oil feed pipe	1	
37	93WF16-024	Plate, filter bracket	1	
38	93WF1-017	Pipe	2	
39	93WF16-011	Sub-tank	1	
40	93WF16-012	Rubber cap	2	
41	93WF16-013	Felt	1	
42	93WF16-014	Packing	1	
43	33T3-007	Screw	3	
44	93WF16-015	Screw	2	
45		Oil tube	1	L=450
46	21WF7-006	Tube clip	1	
47	93WF16-016	Cushion clamp	1	
48	93WF1-009	Washer	1	
49	33T3-007	Screw	1	
50		Oil tube	1	L=5
51	93WF16-017	Tube support	1	
52		Washer	1	GB/T 97.1 4
53		Oil tube	1	170

18. Bobbin winder mechanism

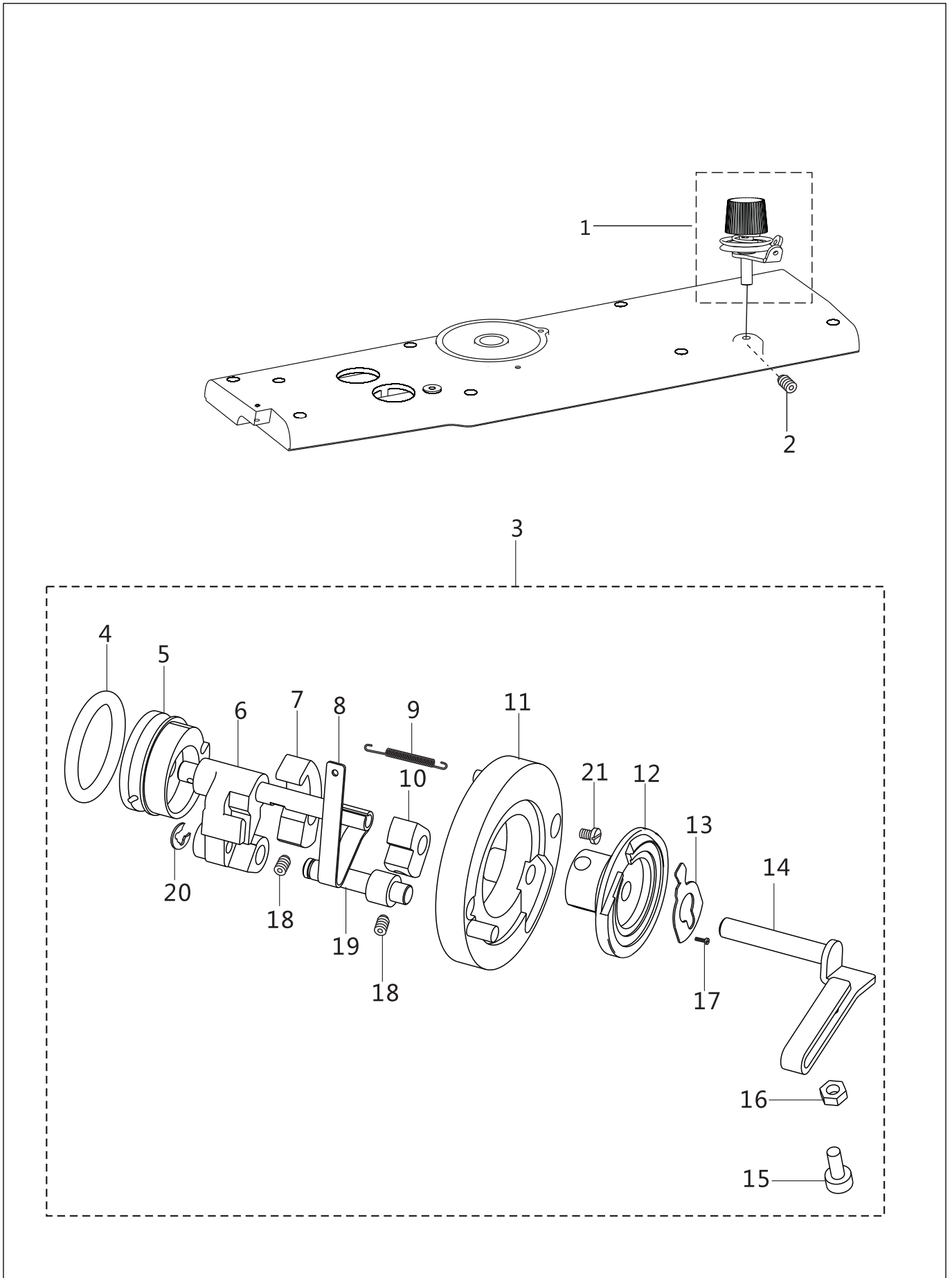

18. Bobbin winder mechanism

NO.	PARTS NO.	PARTS NAME	QTY		REMARK
			TW 1- 898L14D2T5	TW 2- 898L14D2T5	
1	447WF1-005	Thread tension complete	1	1	
2	93WF17-012	Screw	1	1	
3	394WF17-001	Bobbin winder assy.	1	1	
4	394WF17-001A	Rubber ring	1	1	
5	394WF17-001B	Roller base	1	1	
6	394WF17-001C	Crank	1	1	
7	394WF17-001D	Crank	1	1	
8	394WF17-001E	Spring	1	1	
9	394WF17-001F	Spring	1	1	
10	394WF17-001G	Crank	1	1	
11	394WF17-001H	Winder base	1	1	
12	394WF17-001I	Bobbin base	1	1	
13	394WF17-001J	Knife	1	1	
14	394WF17-001K	Shaft	1	1	
15	394WF17-001L	Nut	1	1	
16	394WF17-001M	Screw	1	1	
17	394WF17-001N	Screw	1	1	
18	394WF17-001O	Screw	2	2	
19	394WF17-001P	Pin	1	1	
20	394WF17-001Q	Spring	1	1	
21		Screw	2	2	GB/T 823 M4X10

19. Thread trimmer mechanism

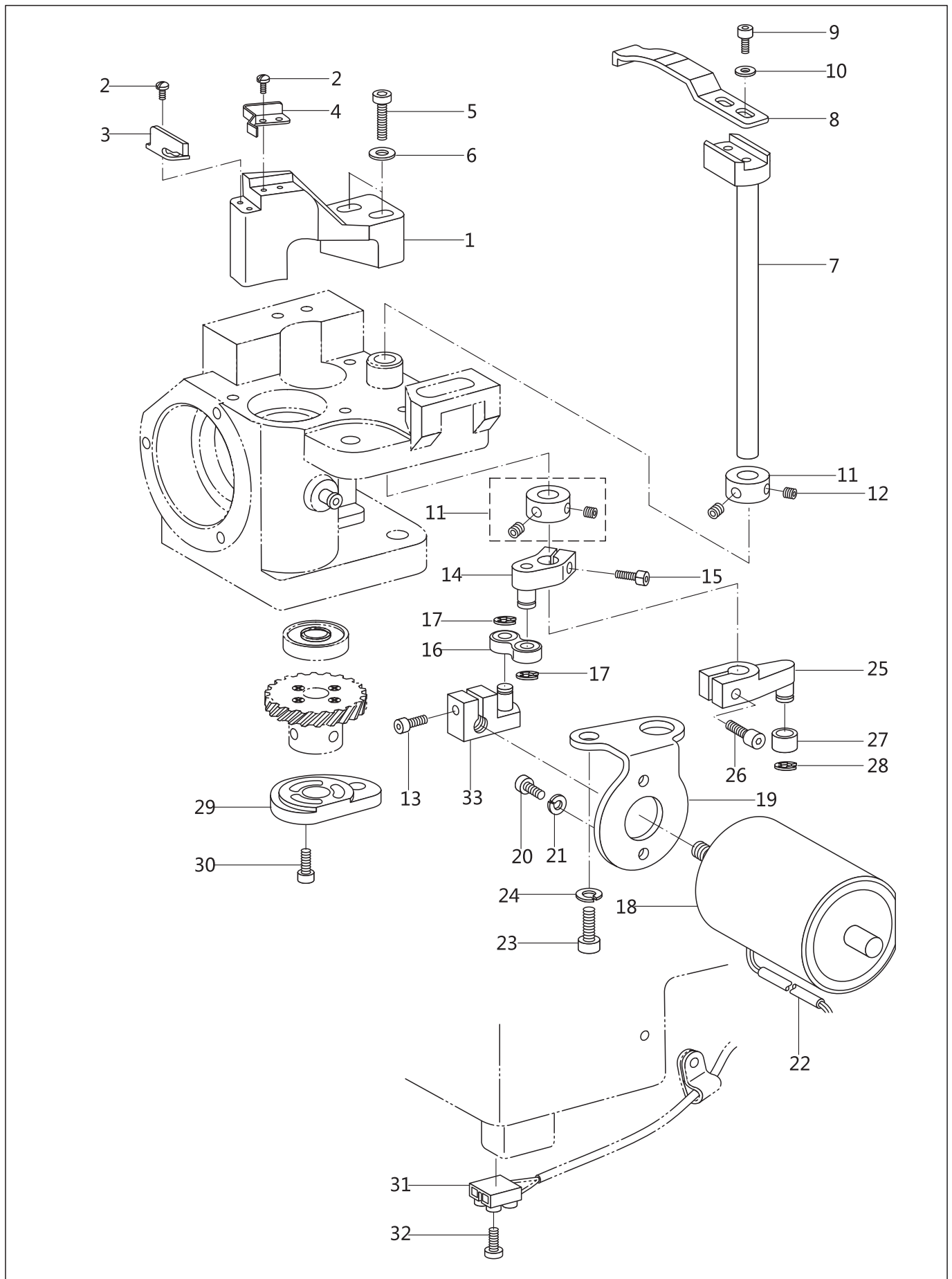

19. Thread trimmer mechanism

NO.	PARTS NO.	PARTS NAME			REMARK
			TW 1- 898L14D2T5	TW 2- 898L14D2T5	
1	93WF19-007	Support bracket, F-knife	1	1	
2	93WF19-001	Screw	4	4	
3	93WF19-002	Fixed knife	1	1	
4	93WF19-003	Spring, thread holding	1	1	
5	93WF19-008	Bolt	2	2	
6		Washer	2	2	GB/T 848 5
7	93WF19-010	Driving knife shaft	1	1	
8	93WF19-004	Driving knife	1	1	
9	93WF8-036	Bolt	2	2	
10		Washer	2	2	GB/T 97.1 3
11	93WF19-005	Collar	2	2	
12	93WF9-002	Set screw	4	4	
13	93WF13-006	Bolt	3	3	
14	93WF19-015	Driving knife arm assy.	1	1	
15	93WF8-031	Bolt	4	4	
16	93WF19-016	Driving knife connection	1	1	
17		Retaining ring	2	2	GB896 3
18	304WF19-001	Thread trimmer solenoid	1	1	SMT-4357SL
19	93WF19-019	Solenoid setting plate	1	1	
20	93WF13-006	Bolt	2	2	
21		Washer	2	2	GB 859 4
22	117WF19-001	Wire	1	1	
23	93WF6-035	Bolt	1	1	
24		Washer	1	1	GB 859 6
25	93WF19-020	Driving knife arm	1	1	
26	93WF19-021	Bolt	1	1	
27	93WF19-006	Roller	1	1	
28	93WF11-006	Retaining ring	1	1	
29	93WF19-022	Thread trimmer cam	1	1	
30	93WF8-031	Bolt	3	3	
31	80WF2-021	Terminal block	1	1	
32		Screw	1	1	GB/T 65 M2.5×16
33	93WF19-023	Driving knife arm assy.	1	1	

19. Thread trimmer mechanism (2-needle machine)

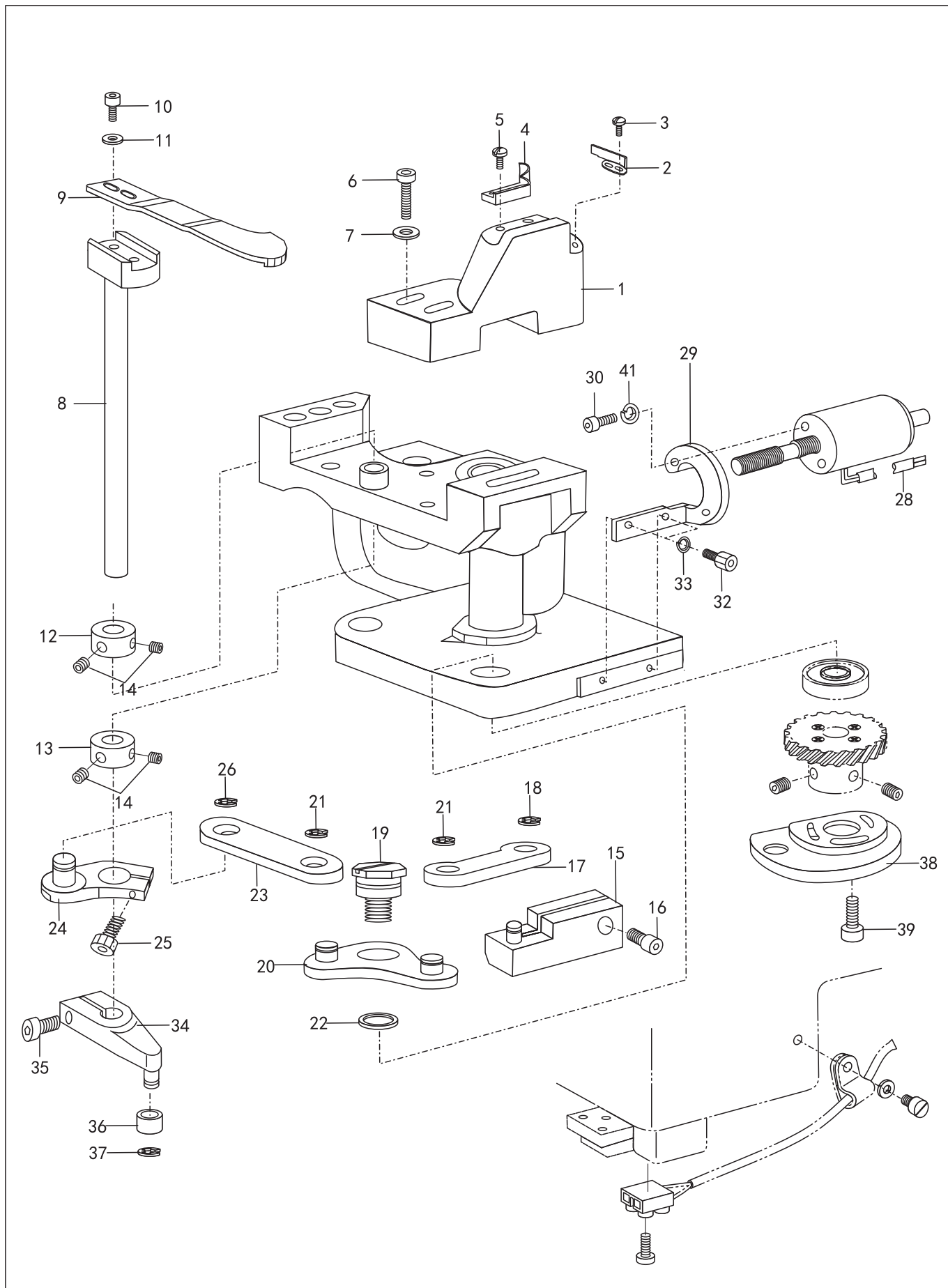

19. Thread trimmer mechanism (2-needle machine)

NO.	PARTS NO.	PARTS NAME	QTY	REMARK
			TW2-898L14D2T5	
1	93WF19-007	Support bracket, F-knife	1	
2	93WF19-002	Fixed knife	1	
3	93WF19-001	Screw	2	
4	93WF19-003	Spring, thread holding	1	
5	93WF19-001	Screw	2	
6	93WF19-008	Bolt	2	
7		Washer	2	GB/T 848 5
8	93WF19-010	Driving knife shaft	1	
9	93WF19-004	Driving knife	1	
10	93WF8-036	Bolt	2	
11		Washer	2	GB/T 97. 1 3
12	93WF19-005	Collar	1	
13	193WF19-001	Collar	1	
14	93WF19-002	Set screw	4	
15	193WF19-002	Connector assy.	1	
16	93WF13-006	Bolt	1	
17	193WF19-003	Link	1	
18		Retaining ring	1	GB896. 3
19	193WF19-004	Screw	1	
20	193WF19-005	Swing board assy.	1	
21		Retaining ring	1	GB896. 3
22	193WF19-006	Retaining ring	1	
23	193WF19-007	Link	1	
24	193WF19-008	Crank assy.	1	
25	93WF8-031	Screw	1	
26		Retaining ring	1	GB896. 3
27				
28	304WF19-001	Thread trimmer solenoid	1	
29	193WF19-010	Solenoid setting plate	1	
30	93WF13-006	Screw	2	
31		Washer	2	GB859. 4
32	93WF13-006	Screw	2	
33		Washer	2	GB859. 4
34	93WF19-020	Driving knife arm assy.	1	
35	93WF19-021	Bolt	1	
36	93WF19-006	Roller	1	
37	93WF11-006	Retaining ring	1	
38	93WF19-022	Thread trimmer cam	1	
39	93WF8-031	Screw	3	

20. Thread tension mechanism(1-needle machine)

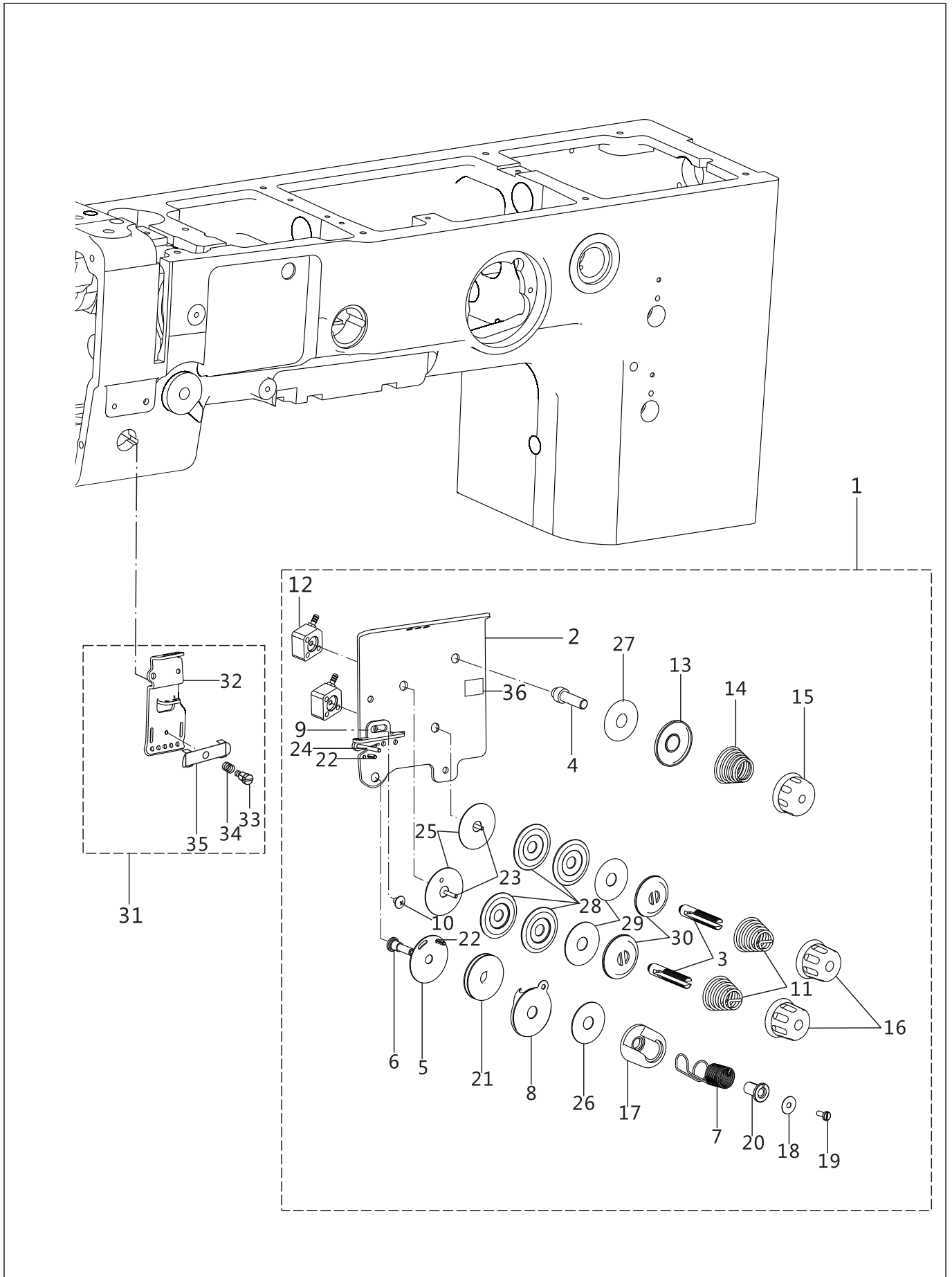

20. Thread tension mechanism(1-needle machine)

NO.	PARTS NO.	PARTS NAME	QTY	REMARK
			TW1-898L14D2T5	
1	394WF20-001	Thread tension complete	1	
2	394WF20-001A	Tension bracket	1	
3	394WF20-001B	Tension screw shaft	2	
4	394WF20-001C	Pretension screw shaft	1	
5	394WF20-001D	Disc	1	
6	394WF20-001E	Screw bar	1	
7	394WF20-001F	Thread take up spring	1	
8	394WF20-001G	Tension controller	1	
9	411WF20-004	Thread guide	1	
10	394WF20-001H	Screw	1	GB818 M4×5
11	411WF20-005	Tension spring	2	
12	444WF2-002B	Cylinder	2	ACQ10×1.5
13	394WF20-001I	Tension disc	2	
14	394WF20-001J	Tension spring	1	
15	394WF20-001K	Nut	1	
16	394WF20-001L	Nut	2	
17	394WF20-001M	Spring controller	1	
18	394WF20-001N	Washer	1	
19	394WF20-001O	Screw	1	
20	394WF20-001P	Bush	1	
21	394WF20-001Q	Roller	1	
22	394WF20-001R	Pin	1	
23	394WF20-001S	Tension release pin	2	
24	394WF20-001T	Pin	1	
25	394WF20-001U	Washer	2	
26	394WF20-001V	Washer	1	
27	394WF20-001W	Washer	1	
28	394WF20-001X	Tension disc	4	
29	394WF20-001Y	Washer	2	
30	394WF20-001Z	Tension release disc	2	
31	200WF20-004	Thread guide assy.	1	
32	200WF20-004A	Thread guide	1	
33	92WF2-015D	Screw	1	
34	92WF2-015C	Spring	1	
35	92WF2-015B	Tension plate	1	
36	411WF1-007	Label	1	

20. Thread tension mechanism (2-needle machine)

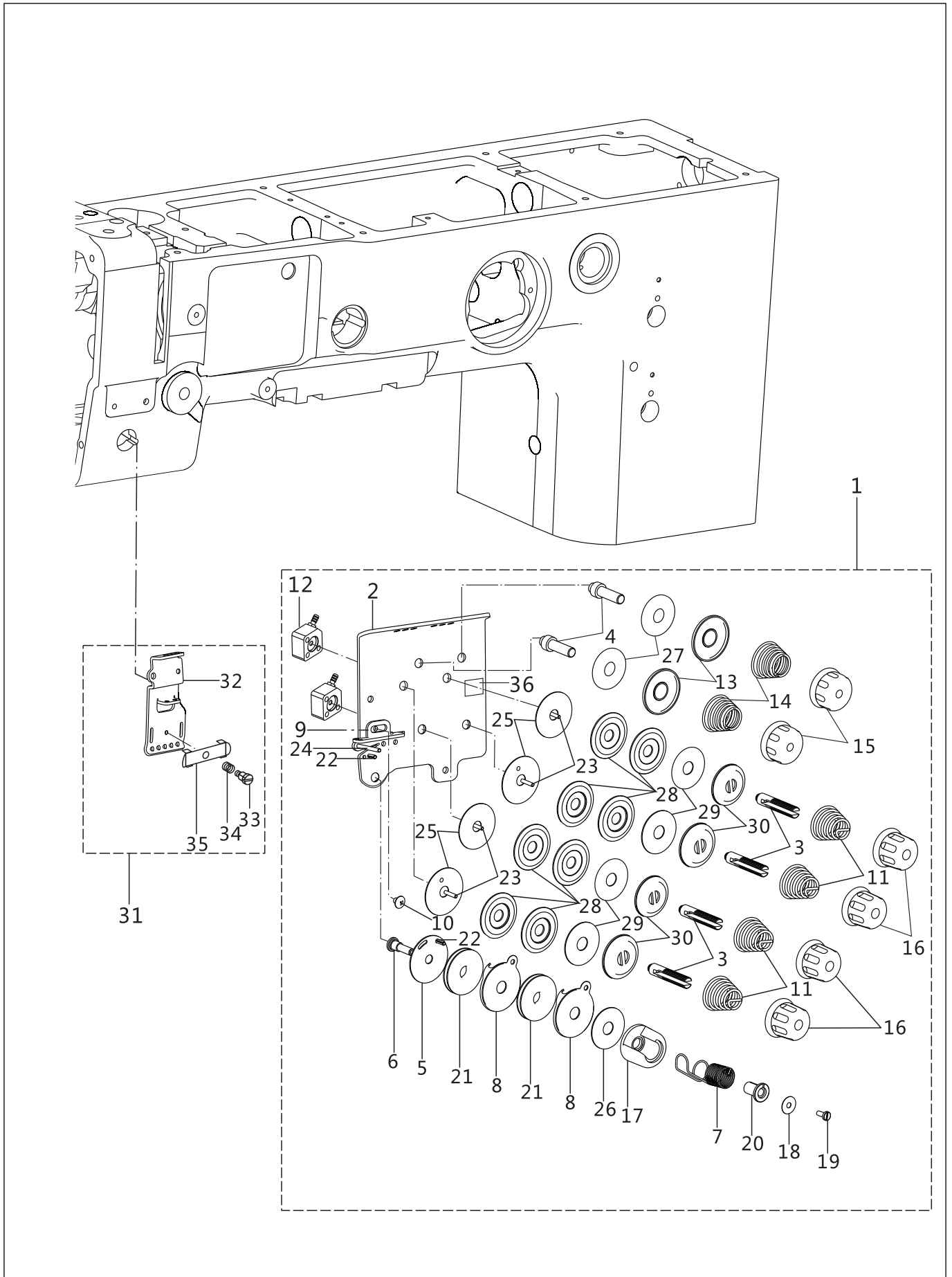

20. Thread tension mechanism (2-needle machine)

NO.	PARTS NO.	PARTS NAME	QTY	REMARK
			TW2-898L14D2T5	
1	458WF20-001	Thread tension complete	1	
2	458WF20-001A	Tension bracket	1	
3	394WF20-001B	Tension screw shaft	4	
4	394WF20-001C	Pretension screw shaft	2	
5	394WF20-001D	Disc	1	
6	394WF20-001E	Screw bar	1	
7	458WF20-001B	Thread take up spring	1	
8	394WF20-001G	Tension controller	2	
9	411WF20-004	Thread guide	1	
10	394WF20-001H	Screw	1	GB818 M4×5
11	411WF20-005	Tension spring	4	
12	444WF2-002B	Cylinder	4	ACQ10×1.5
13	394WF20-001I	Tension disc	4	
14	394WF20-001J	Tension spring	2	
15	394WF20-001K	Nut	2	
16	394WF20-001L	Nut	4	
17	394WF20-001M	Spring controller	1	
18	394WF20-001N	Washer	1	
19	394WF20-001O	Screw	1	
20	394WF20-001P	Bush	1	
21	394WF20-001Q	Roller	2	
22	394WF20-001R	Pin	1	
23	394WF20-001S	Tension release pin	4	
24	394WF20-001T	Pin	1	
25	394WF20-001U	Washer	4	
26	394WF20-001V	Washer	1	
27	394WF20-001W	Washer	2	
28	394WF20-001X	Tension disc	8	
29	394WF20-001Y	Washer	4	
30	394WF20-001Z	Tension release disc	4	
31	200WF20-004	Thread guide assy.	1	
32	200WF20-004A	Thread guide	1	
33	92WF2-015D	Screw	1	
34	92WF2-015C	Spring	1	
35	92WF2-015B	Tension plate	1	
36	458WF1-001	Label	1	

21. Manual switch mechanism

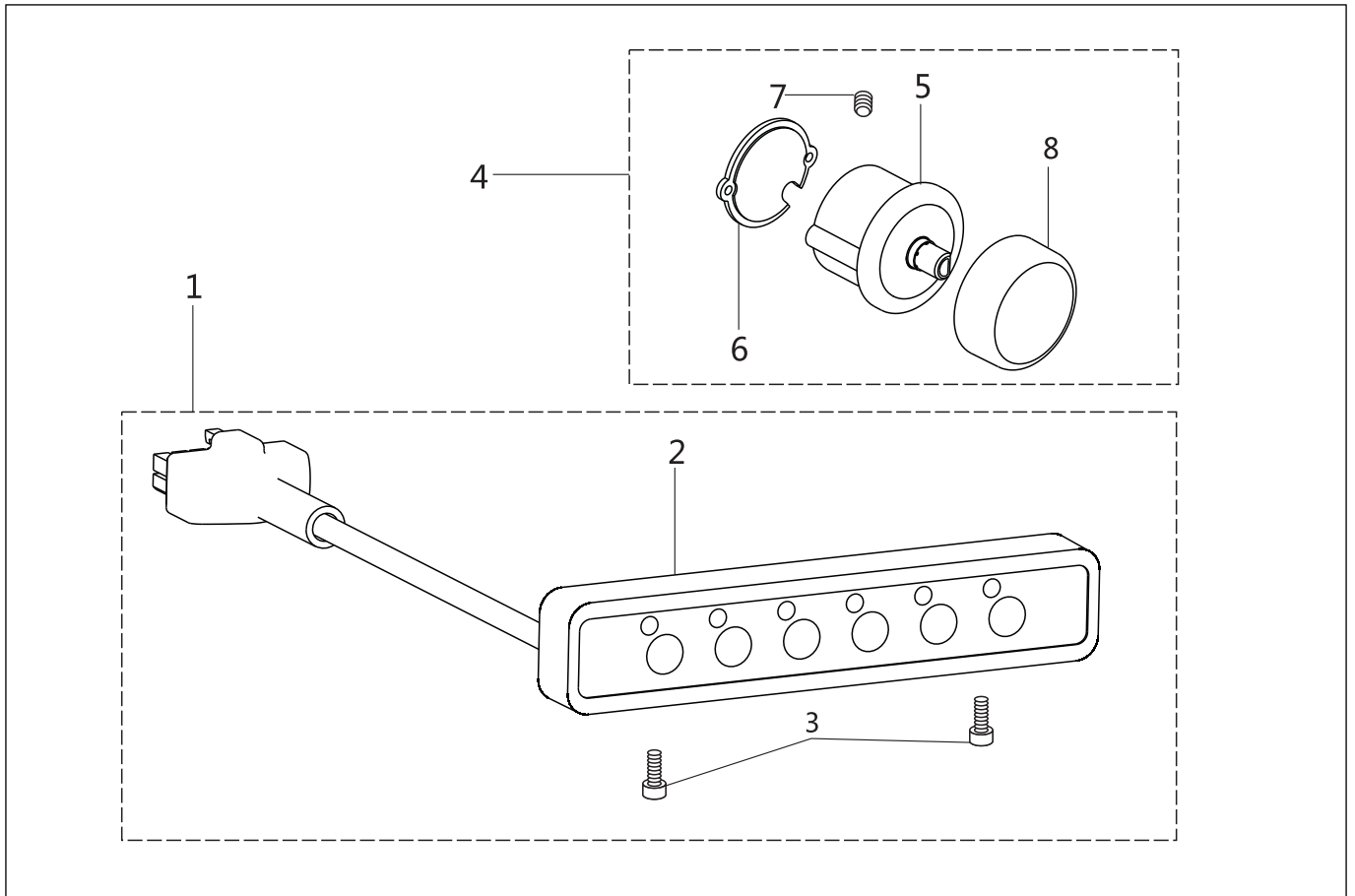

NO.	PARTS NO.	PARTS NAME	QTY		REMARK
			TW 1- 898L14D2T5	TW 2- 898L14D2T5	
1	394WF21-001	Switch assy.	1	1	GB/T 67 M4X8
2	394WF21-001A	Switch setting body	1	1	
3		Screw	2	2	
4	394WF21-002	Electric handwheel assy.	1	1	
5	394WF21-002a	Electric handwheel	1	1	
6	394WF21-002b	Back cover	1	1	
7	93WF17-012	Screw	1	1	
8	559039515	Dial	1	1	

22. Air presser mechanism

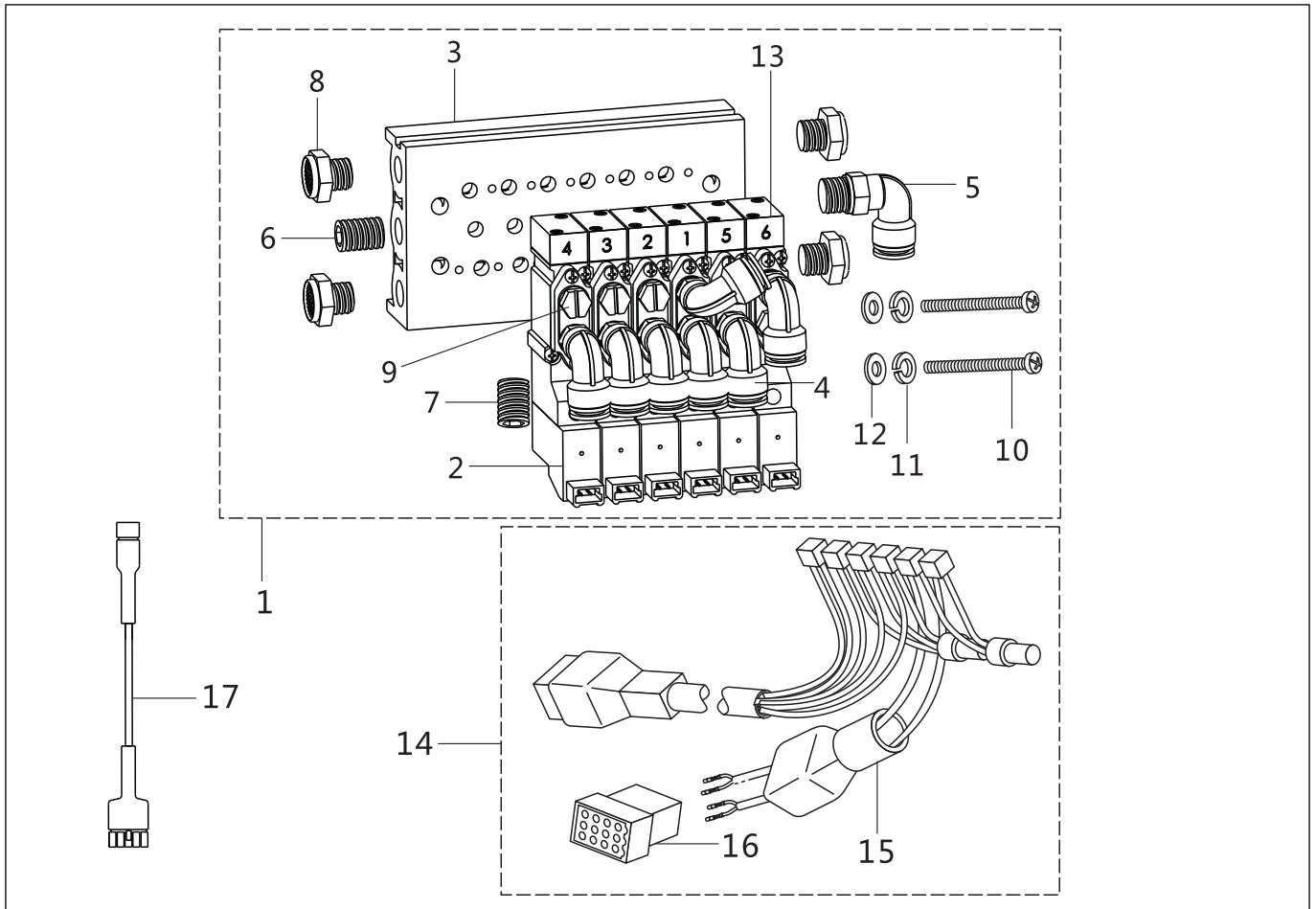

NO.	PARTS NO.	PARTS NAME	QTY		REMARK
			TW 1- 898L14D2T5	TW 2- 898L14D2T5	
1	394WF22-001	Solenoid valve assy.	1	1	
2	394WF22-002	Solenoid valve	6	6	KV110-4P
3	394WF22-003	Air manifold	1	1	MK100B-06
4	394WF22-004	Joint	7	7	PL4-M5T
5	394WF22-005	Joint	1	1	PC6-01T
6	394WF22-006	End cap	1	1	1/8
7	394WF22-007	Silencer	1	1	BST-01
8	394WF22-011	Silencer	4	4	
9	394WF22-008	End cap	5	5	LP-M5
10		Screw	2	2	GB/T818 M4X30
11		Washer, spring	2	2	GB 859 4
12		Washer	2	2	GB/T97.1 4
13	411WF22-001	Label	1	1	
14	394WF22-010	Wire assy.	1	1	
15	356WF4-003	Cover	1	1	RAL7015
16	356WF4-002	Cover	1	1	
17	385WF5-010	Transfer wire for knee switch	1	1	

23. Presser foot actuator mechanism

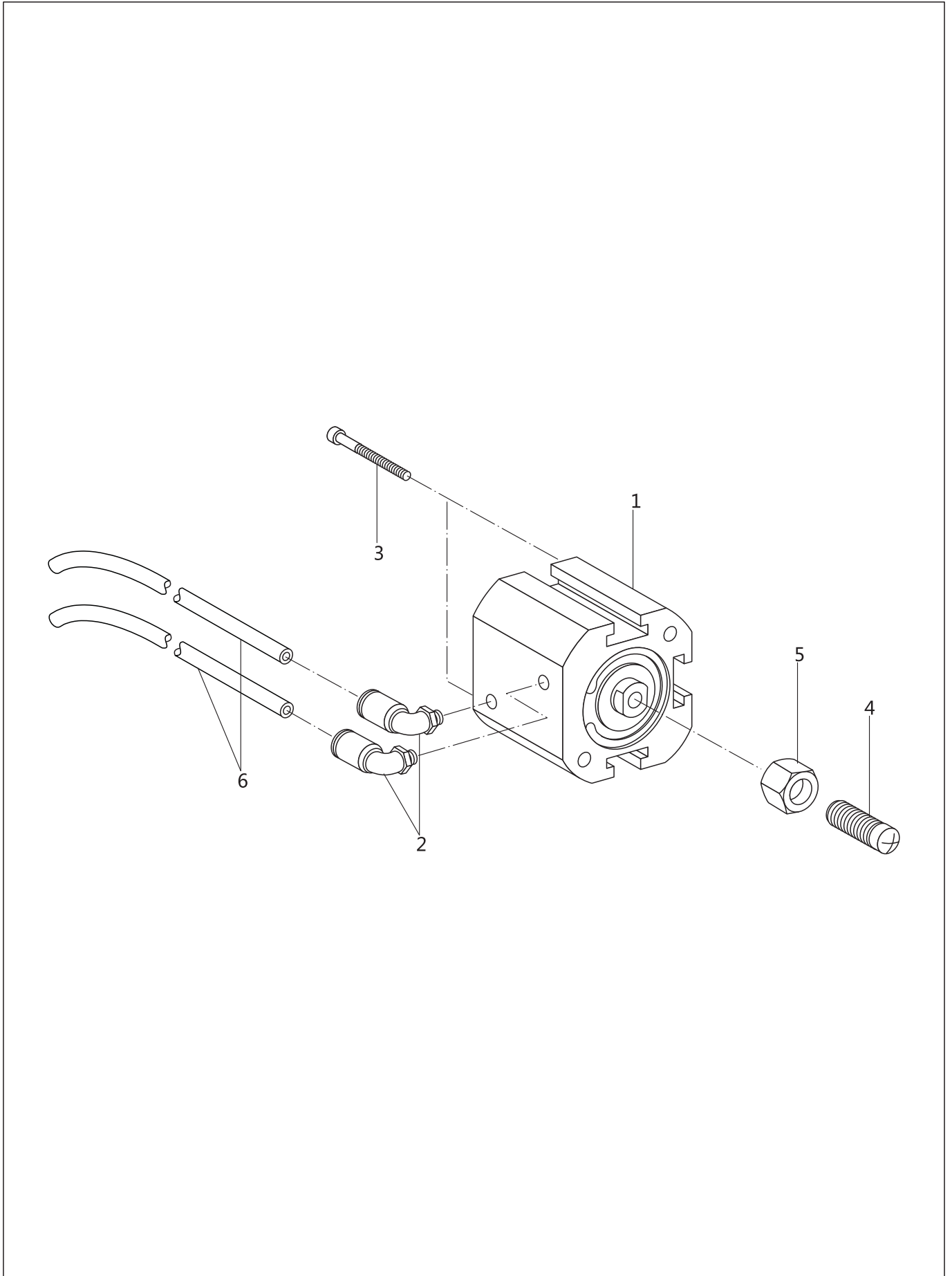

23. Presser foot actuator mechanism

NO.	PARTS NO.	PARTS NAME	QTY		REMARK
			TW 1- 898L14D2T5	TW 2- 898L14D2T5	
1	93WF23-001	Cylinder	1	1	SU239 32×20
2	93WF23-002	Joint	2	2	APL4
3		Bolt	2	2	GB/T 70.1 M5×45
4	93WF23-004	Screw	1	1	
5	93WF23-005	Nut	1	1	GB/T 6172.1 M8
6		Air tube	2	2	870mm

24. Accessories

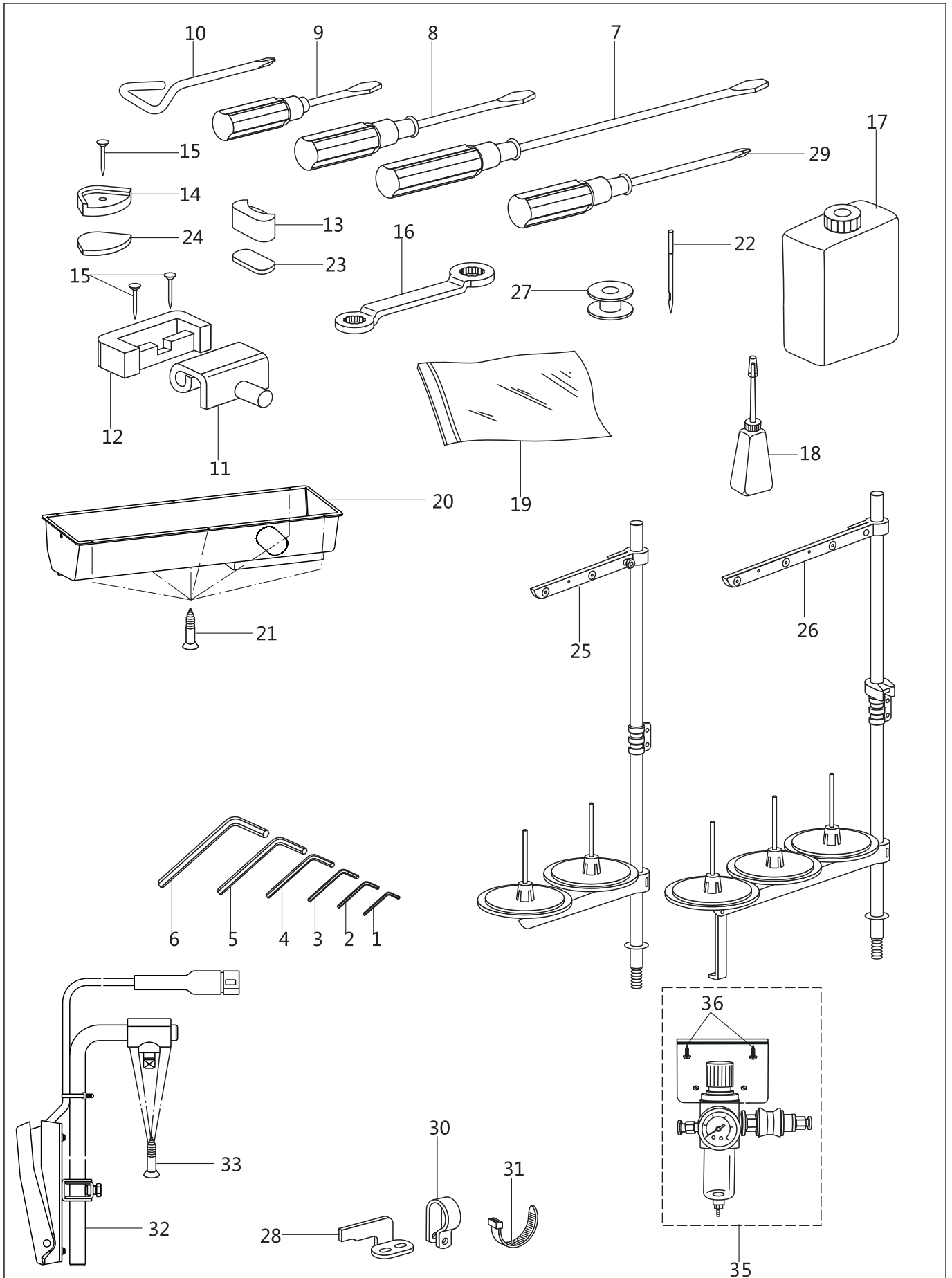

24. Accessories

NO.	PARTS NO.	PARTS NAME	QTY		REMARK
			TW 1- 999L14D2T5	TW 2- 999L14D2T5	
1		Hexagonal wrench	1	1	S=1.5
2		Hexagonal wrench	1	1	S=2
3		Hexagonal wrench	1	1	S=2.5
4		Hexagonal wrench	1	1	S=3
5		Hexagonal wrench	1	1	S=4
6		Hexagonal wrench	1	1	S=5
7	33TF-012	Screw driver, L	1	1	
8	33TF-013	Screw driver, M	1	1	
9	33TF-014	Screw driver, S	1	1	
10	93WF24-015	Screw driver, plus	1	1	
11	22T9-007F1	Hinge	2	2	
12	17WF8-011	Rubber cushion	2	2	
13	93WF24-002	Corner support	2	2	
14	93WF24-003	Head cushion	2	2	
15		Nail	6	6	SG162
16		Double wrench	1	1	8×10 GB/T4388-1995
17	1F-012	Oil tank	1	1	
18	33TF-011	Oiler	1	1	
19	33TF-010	Accessories bag	1	1	
20	394WF24-008	Oil pan	1	1	
21		Wood screw	6	6	GB 845 ST3.5×13
22		Needle	4	4	DP×17 19#
23	93WF24-004	Spacer	2	2	
24	93WF24-005	Spacer	2	2	
25	14F0-00	Thread stand assy.	1	-	
26	1F-014	Thread stand assy.	-	1	
27	93WF4-042	Bobbin	4	4	
28	93WF19-002	Fixed knife	1	1	
29	93WF24-025	Screw driver, hexagonal	1	1	
30	93WF16-016	Cushion clamp	1	1	
31		Cable tie	1	1	4×200
32	200WF21-001	Knee switch	1	1	
33		Screw	4	4	GB846 ST4.2X16
34					
35	177WF10-006	Air integrator	1	1	
36		Screw	2	2	GB846 ST4.2X16

INSTRUCTION MANUAL

YSC-8361 AC Servo System

Please read this manual before using the Controller

Please keep this manual within convenience access for easy reference

Version: V.1.00

For your perfect operation and safety, before using your new machine, please read this instruction manual.

YSC-8561 controller is used for an industrial sewing machine. With industrial sewing machine, it is normal to carry out work while positioned directly in front of moving parts such as the needle and thread take-up, and consequently there is always a danger of injury that can be caused by these parts. So when you ready to operate the machine, please follow the instructions from trained personnel and instructors regarding safe and correct operation.

1. NOTICE

1.1 Work environment

- ▲ Please use 220V AC in $\pm 10\%$ ranges.
- ▲ To avoid the false operate, please keep the product away from the high electromagnetic interference.
- ▲ Please operate in the area which temperature is $5\text{ }^{\circ}\text{C} \sim 45\text{ }^{\circ}\text{C}$ and humidity is 80% or less.













1.2 Notice of installation





- ▲ Turn off the power and unplug the cord before installation.
- ▲ The wire must not set to be near the wheel and other movable parts.
- ▲ To avoid the static interference and current leakage, all grounding must be done.

1.3 Notice of safety

- ▲ Turn off the power before maintenance and repairs or raising the machine arms, or changing needle, or threading needle.
- ▲ Please don't open the box except the professional.
- ▲ When turn on the machine in the first time, use low speed to operate and check the correct rotation direction.
- ▲ During machine operation, don't touch any moving parts.
- ▲ All moving parts must use the protective device to avoid the body contact and objects insertion.
- ▲ When there is water or other liquid, or caustic material on box or motor, you must stop operation and turn off the power.
- ▲ All connector shouldn't be plug and unplug when power on.
- ▲ The connector should be plug and unplug in the correct method.

2. OPERATING FIELD P200B

Start backtack		Single start tacking, A is the stitches of forth sewing; B is the stitches of back sewing. They are both in range 1~15
		Double start tacking, A is the stitches of forth sewing; B is the stitches of back sewing. They are both in range 1~15.
End backtack		Single end tacking, C is the stitches of back sewing; D is the stitches of forth sewing. They are both in range 1~15
		Double end tacking, C is the stitches of back sewing; D is the stitches of forth sewing. They are both in range 1~15
Free Sewing		<p>▲ As the pedal is stepped forward, the starttacking(if selected) will be done automatically, then machine will start normal sewing. Once the pedal returned to balance, machine will stop immediately.</p> <p>▲ As the pedal stepped backward, the end tacking, trimming and wiping(if selected) will be done automatically</p>
Constant-Stitch		<p>▲ Once the pedal is stepped forward, F, G stitches will be completed with E times.</p> <p>▲ Constant-Stitch Sewing will perform the number of segments and times as setting, when the stitches are zero, machine will stop immediately.</p>
Bar-Tacking Sewing		<p>▲ Once the pedal is stepped forward, all the seams of bar tacking, A, B, C, D sections will be completed with E times, and the trimming will be done automatically.</p> <p>▲ The pedal must be returned to balance for next sewing.</p>
Lower thread Counter		Enter lower thread counter interface
Soft start		Enable or disable the soft start
Needle Up / Needle Down		Select the stop position of needle bar
Trimming Enable		Enable or disable the trimming
Interface Selection		Switch current interface to another
One-Key Default /Lock keys		<p>▲ Sewing interface: lock the keypad</p> <p>▲ Parameter interface: restore a parameter to default</p>

Parameter Function		Enter or exit parameter function interface
Save		Confirm and save current value of parameter
Add		Value increase
Sub		Value decrease

3. OPERATING ELEMENTS

3.1 Single start back-tacking setting

- A Stitches = 0
Seven-segment display A display 『-』 .
Sewing process: B stitches back – normal sewing.
- A Stitches ≠ 0
Sewing process: A stitches forth – B stitches back – normal sewing

3.2 Double start back-tacking setting

- A Stitches = 0
Sewing process: B stitches back – B stitches forth – B stitches back – normal sewing.
- A Stitches ≠ 0
Sewing process: A stitches forth – B stitches back – A stitches forth – B stitches back – normal sewing

3.3 Single end back-tacking setting



- A Stitches = 0
Seven-segment display D display 『-』 .
Sewing process: C stitches back – end.
- A Stitches ≠ 0
Sewing process: C stitches back – D stitches forth – end.



3.4 Double end back-tacking setting

- A Stitches = 0
Sewing process: C stitches back – C stitches forth – C stitches back – end.
- A Stitches ≠ 0
Sewing process: C stitches back – D stitches forth – C stitches back – D stitches forth – end.

3.5 Lower thread counter



Set A11 to "1" to active the counter.

- Enter interface:** Press  Or Special function interface SN F6(refer to 6.6).
- Initialize the counter:** Press , the initial value of the lower thread counter which was set previously will be shown. Adjust it to a suitable value.
- How the counter works:**
 - Display initial value

- ☒ The counter reduces by 1 for every 10 stitches sewn.
- ☒ If the counter less than 1, the display area twinkled and buzzer sounds for 3 times. The machine will not start up again. Press  the warning will disappear and sewing will be possible, the counter reduces continue.
- ☒ Press  again, the display will return to the initial value

3.6 Product quantity counter

Set A11 to "1" to activate the counter.

- ☒ **Enter interface:** Special function interface SN F2, refer to 6.2
- ☒ **Data acquisition:** In SN F2 interface, press  will be into collect process interface, seven-segment display D displays 『L』, seven-segment displays E,F,G will display the number of stitches for this process. It records the number of stitches and the number of trimmer. Press  to save the data and return SN F2 interface.
- ☒ **How the Counter works:** If sewn the number stitches more than the number of stitches collected 90%, and the number of trimming times more than collected, the counter add 1.
- ☒ **Clear Counter:** press 

3.7 Adjust the backtack

- ☒ Adjusting of RVE.SOL action time

For start/end backtack or bar tacking, if unbalanced situation is appeared during natural direction to reverse direction, please correct it as below:

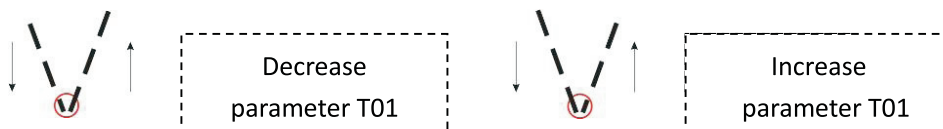

- ☒ Adjusting of RVE.SOL release time



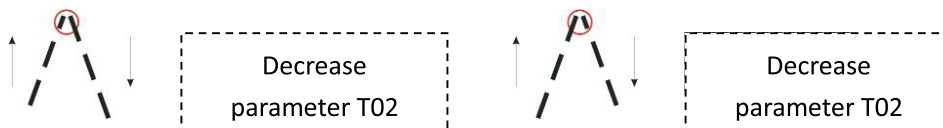



For start/end tacking or bar tacking, if unbalanced situation is appeared during reverse direction to natural direction, please correct it as below:



3.8 Quick functions on the keypad



Figure 1: Keypad on the machine arm

Foot stroke		Toggle foot stroke level
Start and end strips		This key cancels the general setting for sewing start and end strips. If strips are activated, pressing the key disables the next strip. If no strips are activated pressing the key sews the next strip.
Position of the needle		If the key is selected the needle moves to a specific position. This position is determined individually via the parameter settings, more information read D15, D16
Stitch Length		If this key is selected, the machine sews using the smaller stitch length selected at lower adjusting wheel for the stitch length
Additional thread tension		This key switches on the additional thread tension
Pause		If the pause switch is triggered, all functions are locked except parameters, the adjacent led light up, panel display "PAUSE"

3.9 Lock the hot keys and keypad

if  key is triggered, all functions on the keypad and hot keys are invalid.

3.10 Electronic hand wheel

The value of "A23" is 1, electronic hand wheel is activated. By turning the hand wheel, you can move the needle bar forwards or backwards.

3.11 Hot keys

Pressing the Reverse switch:

Default: Reverse.

Refer to Parameter list, A04.

Pressing the hand wheel:

Default: None

Refer to Parameter list, A05.

3.12 Quick stroke adjustment via knee switch

On machines with quick stroke adjustment activated via a knee switch, the elevated sewing foot stroke is switched via the knee switch.

4. OPERATION OF THE SPECIAL FUNCTION INTERFACE

Press  could be access special function interface from normal function interface, showed as below:

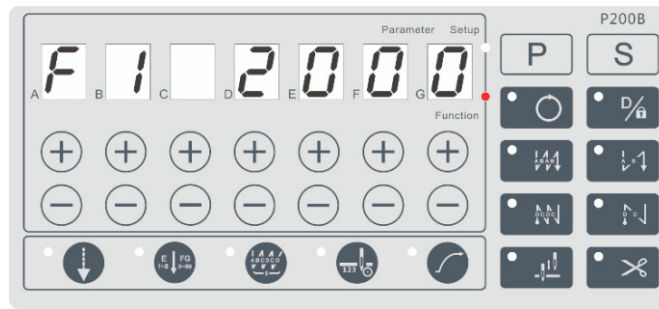

Figure 2: Function Interface

Bar A and B according to SN of function, bar D~G display contents, press **B+** and **B-** to select function:

4.1 Dynamic speed limitation

SN F1: display current speed up limitation, could be change during running.

4.2 Product quantity counter

SN F2: display the product quantity

4.3 Machine degree

SN F3: display the machine degree.

4.4 Torque enhancement function at low speed

SN F4: display D: press **D+** and **D-** to open/close the function.

Display F,G: 0~10, the gear.

4.5 Actual speed display

SN F5: display the actual speed.

4.6 Lower thread counter

SN F6: display how much the lower thread is remaining

5. PARAMETER INSTRUCTION

5.1 Setting parameter

Press to enter Parameter Interface.

Seven-Segment display E display the parameter type, press "**E+**" and "**E-**" key to change it.

Seven-Segment display F, G display the parameter index, press "**F+**", "**F-**", "**G+**", "**G-**" key to change it.

Seven-Segment displays A, B, C, D display the parameter value, press the keys under them to change it.

For example, Graph4: parameter index is 1, type is P, value of "S01" is 2000, the nixie tube will blink when change the value. Press to confirm, press to cancel and return to sewing interface.

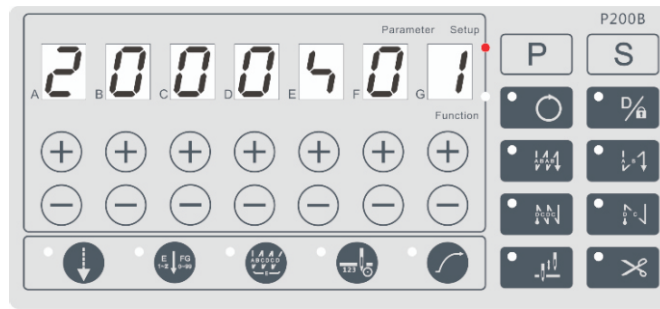

Figure 3: Parameter Interface

5.2 Get the permission of setting O type parameter

Only S, T and A type parameter can be select normally, if you want to change the O type parameter, you must power on while press **P** key, when you see 『DO EN』, you get the permission successfully.

5.3 Parameter solidifying

If users want to change some parameter's default value, then select the parameter, press **○** maintain a moment, after 『SD OK』 displaying, the default value has been changed.

5.4 Restore parameter through one-key default

Select any parameter in parameter interface, **D/A** default value. The bar will be twinkling if modified, use **S** to confirm or **P** repeal change

5.5 Controller recovery

- Resume the default value of all parameters**
Set parameter **O17** to "ON", turn on the power again, after twinkling of "INIT" finished, all parameters have been default value themselves
- Restore Factory Defaults**
Set parameter **O51** to "ON", turn on the power again.

5.6 Abate safety switch

If you want to abate the function of Safe SW., you can change the value of "**O31**" from "1" to "0" normally, in a particular case, for example, the Safe SW. broke down, you can power on while press "**C+**" key to abate the function of Safe SW.

warning: it means potential security problems for you if you abate the function of Safe SW., so attention please.

5.7 General parameter table

SN	RANGE	DESCRIPTION
S type Parameter		
S01	500~3500spm	Maximum sewing speed
S02	150~500spm	Minimum sewing speed
S03	500~2000spm	Speed adjustment for start back-tacking

S04	500~2000spm	Speed adjustment for end back-tacking
S05	500~2000spm	Speed adjustment for bar-Tacking
S06	500~2000spm	Speed adjustment for constant-stitch sewing
S07	150~300spm	Speed adjustment for trimmer
S08	200~500spm	Soft start speed
S09	500~3500spm	Speed adjustment for foot stroke gear 1
S10	500~3500spm	Speed adjustment for foot stroke gear 2
S11	500~3500spm	Speed adjustment for foot stroke gear 3
S12	500~3500spm	Speed adjustment for foot stroke gear 4
S13	500~3500spm	Speed adjustment for foot stroke gear 5
S14	500~3500spm	Speed adjustment for foot stroke gear 6
S15	500~3500spm	Speed adjustment for min-foot stroke
S16	50~500spm	Speed adjustment for pull back after trim
T type Parameter		
T01	1~200(millisecond)	Action time of the REV SOL.
T02	1~200(millisecond)	Release time of the REV SOL.
T05	1~500(millisecond)	Foot lifer-Delay time adjustment for pedal's feet lift position
T06	1~500(millisecond)	Running delay time adjustment for Automatic Foot Lifer
T09	1~1000(millisecond)	Safety switch-Delay time adjustment for machine vibration
T10	1~200(millisecond)	Pedal-Delay time adjustment for pedal vibration
T11	1~1000(millisecond)	Delay time adjustment when A20/A22 set as 1
A type Parameter		
A01	0~1	Needle positions 1 = Up Position 0 = Down Position
A02	0~1	Automatic Constant-Stitch sewing 1 = On 0 = Off
A03	0~1	Correction stop mode 1 = stop position accord to D15, D16 0 = random
A04	0~13	Function selection of reverse switch 0 = none 1 = reverse 2 = half stitch correction 3 = continuously correction 4 = half stitch correction at machine stop, reverse at machine run 5 = continuously correction at machine stop, reverse at machine run

		6 = none 7 = trim at normal sewing, foot lifer after trimming 8 = foot lifer 9 = foot stroke 10 = single backtack supression 11 = 2 nd STITCH LENGTH 12 = additional thread tension 13 = thread mode
A05	0~13	Function selection of hand wheel switch, refer to A04
A06	0~1	Trim selection 1 = trimmer valid 0 = trimmer invalid
A07	0~1	Lock machine buttons selection (machine buttons includes Hot Keys, Hand Wheel Switch, Reverse Switch) 0: machine buttons work 1: machine buttons not work
A09	0~1	Foot lift selection 1: Foot lifer function valid 0: Foot lifer function invalid
A10	0~1	Clamp selection 1: Clamp valid 0: Clamp invalid
A11	0~1	Product Quantity Counter 1 = On 0 = Off
A12	0~1	Lower thread Counter 1 = On 0 = Off
A13	0~1	Pull Back after Trim (angle refer to O35) 1 = On 0 = Off
A14	0~1	Automatic Foot Lifer when stopped 1 = ON 0 – Off
A15	0~1	Automatic Foot Lifer after trimming 1 = On 0 = Off
A16	0~1	Automatic constant-stitch sewing after start backtacking (only when A02=0) 1 = On 0 = Off
A17	0~1	Automatic end backtacking for constant-stitch sewing (only when A02=0)

		1 = On 0 = Off
A18	0~1	Upper position when switch on the control 1 = On 0 = Off
A19	0~2	Function when Half-Heeling the pedal 2: thread cutting 1: foot lift 0: Balance
A20	0~1	Mode of start backtack 1: stitch for stitch 0: normal
A22	0~1	Mode of end backtack 1: stitch for stitch 0: normal
A23	0~1	Electronic handwheel 1 = On 0 = Off
A27	0~3	Mode of thread tension and thread tension reduction when sewing foot lift is active 0 = no thread tension lift 1 = thread tension lift in the seam 2 = thread tension lift after trimming 3 = thread tension lift in the seam and after trimming
A28	0~1	Automatic release additional thread tension when push the knee switch 1 = ON 2 = Off
D type Parameter		
D01	0~359(°)	Angle of needle bar up lever
D02	0~359(°)	Angle of needle bar down lever
D03	0~359(°)	Switch-on angle of Trimmer
D04	0~359(°)	Switch-off angle of Trimmer
D05	0~359(°)	Switch-on angle of Reverse SOL.
D06	0~359(°)	Switch-off angle of Reverse SOL.
D07	0~359(°)	Switch-on angle of thread clamp
D08	0~359(°)	Switch-off angle of thread clamp
D13	0~359(°)	Switch-on angle of thread tension
D14	0~359(°)	Switch-off angle of thread tension
D15	0~359(°)	Correction angle 1
D16	0~359(°)	Correction angle 2
O type Parameter		
O01	1~10(stitch)	Number of soft start stitches

O04	1~1000(millisecond)	Delay time for stitch for stitch backtrack. Refer to A20
O06	0~1	Automatic foot lifter release 1 = Automatic foot lifter release after the time of O07 0 = always hold
O07	5~30(second)	Refer to O06
O17	0~1	Refer to 5.5
O23	1~60(second)	The running time of aging test
O24	1~60(second)	The idle time of aging test
O25	1~720(hour)	The total time of aging test
O26	0~2	Set to "1/2" active the aging test
O31	0~1	Safety switch function 1 = open 0 = close
O32	0~1	Polarity of safety switch 0 = Normal closed 1 = Normal opened
O35	0~359	Angle of pull back after trimming
O48	0~100	The duty of clamp SOL
O51	0~1	Refer to 5.5
O56	0~4095	Pedal input MAX value: value \geq O57
O57	0~4095	Pedal input dividing value of high speed and low speed: O56 \geq value \geq O58
O58	0~4095	Pedal input dividing value of low speed and Balance: O57 \geq value \geq O59
O59	0~4095	Pedal input dividing value of Balance and Foot lifter: O58 \geq value \geq O60
O60	0~4095	Pedal input dividing value of Foot lifter and Trimming: O59 \geq value \geq O61
O61	0~4095	Pedal input MIN value: value \leq O60
O63	0~5	Pedal mode 0 = linear 1 = polyline 2 = curve(slow \rightarrow quick) 3 = curve(quick \rightarrow slow); 4 = S curve(slow \rightarrow quick \rightarrow slow) 5 = S curve(quick \rightarrow slow \rightarrow quick)
O64	500~5000	The speed of turning point when O63 set as 1
O65	0~4095	The value of turning point: O56 \geq value \geq O57
O68	0~1	Mode of the End Backtack 0 = Stop first, then act RVS SOL; 1 = Act RVS SOL when running
O69	0~1	Correction mode 0 = only the machine stopped

		1 = before trimming
O83	0~720	Step width for electronic hand wheel
O84	0~200	Speed for electronic hand wheel

6. HOW TO ADJUST the ZERO OF THE MACHINE

Press hold  and turn on the power to access to adjust ZERO for the machine.

Press  to confirm and save.

7. ERROE MESSAGES & POSSIBLE TROUBLESHOOTING

ERROE CODE	DESCRIPTION	SOLUTION
PEDAL	Pedal warning	<ul style="list-style-type: none"> - Check or replace the pedal - Pedal not connected - Do not pedal yet
CARE	Safe Switch problem	<ul style="list-style-type: none"> - Check the Safe Switch - Replace the safe switch
KEY1	Machine button warning	<ul style="list-style-type: none"> - Do not press machine button - Replace the buttons
E101	High AC voltage fault	<ul style="list-style-type: none"> - Check mains voltage - Stabilize mains voltage - Use generator
E103	High Bus voltage fault	<ul style="list-style-type: none"> - Check mains voltage - Stabilize mains voltage - Use generator
E106	Bus current overload	<ul style="list-style-type: none"> - Check the encoder and motor - Replace the encoder - Replace the motor
E107	Motor blocked	<ul style="list-style-type: none"> - Eliminate stiff movement in the machine - Replace the encoder - Replace the motor
E110	Encoder/Synchronizer fault	<ul style="list-style-type: none"> - check or replace the synchronizer for a belt-drive machine - check or replace the encoder for a direct-drive machine
E190, E290	Software Update Error	<ul style="list-style-type: none"> - Software update - Replace the control
E191, E291	Software Update Error	<ul style="list-style-type: none"> - Software update - Replace the control
E193, E293	Software Update Error	<ul style="list-style-type: none"> - Software update - Replace the control
E294	Software Update	<ul style="list-style-type: none"> - Software update

	Communication Error	- Replace the control
E199	Software Update Error	- Software update - Replace the control
E900	Communication problem	- Restart the control - Replace the control

8. Controller Check

Press hold **S** during power on, it will display "TEST" and then enter the Check interface. Seven-Segment display A display check index, the else display contents.

8.1 Pedal

Display B,C shows the pedal position status, display D,E,F,G display sample value.

<i>bL</i>	Balance position
<i>L4</i>	Low-speed position, is stepping on the first paragraph
<i>H4</i>	High-speed position, is stepping on the second paragraph
<i>FP</i>	Foot position, anti-step on the first paragraph
<i>rT</i>	Trim position, anti-step on the second paragraph
<i>E-</i>	Not connected or the pedal is faulty

8.2 Synchronizer

Synchronizer: turning the motor, display C value changes from 0 to 1

Position encoder: turning the motor, display D E,F,G value changes between 0 to 720.

8.3 Keypad Test

Display B, C, D, E, F, G correspond to the six keys on keypad, when press the key,

the corresponding display will change from 0 to 1, press **+** to light on the

corresponding LED, press **-** to light off, **S** to light on all and **P** to light off all, the correspondence between the digital tube and the function key is as follows

Display B: foot stroke

Display C: start and end trips

Display D: position of the needle

Display E: stitch length

Display F: additional thread tension

Display G: pause

8.4 Motor encoder

8.5 Output Device

Digital F, G shows the current test solenoid type, the corresponding relationship is as follows

Solenoid	Display
Trimmer	<i>r-</i>
Foot	<i>F0</i>
Reverse	<i>rE</i>

Stroke	4F
Stitch length	4L
Clamp	CL
Main thread tension	7F
Additional thread tension	8F
spare	d4

Press  to test.

8.6 Input Switches

Display C: status of Reverse switch

Display E: status of Safety Switch

Display G: status of Knee Stroke Switch

8.7 Electronic Handwheel

Display B: Rotation

Display C: Press Switch

Display DEFG: Encoder

8.8 Speed Limit Device to stroke

Digital Type: four gears

- Display C shows gear, display E, G display the status of the two switches inside.

Analog Type: Stepless speed change

- Display D, E, F, G show the sample value of the potentiometer.
- Adjustment: press [P] to save two gear position, and press [S] to save six gear position.

8.9 AC voltage

Display the current AC input voltage

e.g: , AC voltage 220v.

8.10 Bus voltage

Display the current bus input voltage

e.g: , bus voltage 310v.

8.11 A phase current sampling reference

8.12 B phase current sampling reference

8.13 AD1 sample value

8.14 AD2 sample value

8.15 AD3 sample value

8.16 AD4 sample value

8.17 Main MCU Software Version

E.g: , version 1.00

8.18 Software Release Date

E.g: , released on October 1, 2016

8.19 Slave MCU Software Version

E.g: ,version1.00

9. Appendix

9.1 Machine ID

9.1.1

Press hold 『A+』 key and turn on the power to access to adjust the machine ID, seven-segment displays F,G will display the ID, change it

and press to save.

9.1.2 Table of maximum speeds

ID	Model	Unit(sti/min)
1		2500
4	TW1-898L14D2T5	3500
5	TW1-999L14D2T5	2800
6	TW1-899SL14D2T5	2500
7	TW1-899SL14D2T5L	2800
8	TW2-898L14D2T5	2800
9	TW2-999L14D2T5	2500

9.2 Seven-Segment Display Characters Compare Table

0	1	2	3	4	5	6	7	8	9
A	B	C	D	E	F	G	H	I	J
K	L	M	N	O	P	Q	R	S	T
U	V	W	X	Y	Z				

9.3 Connector diagram

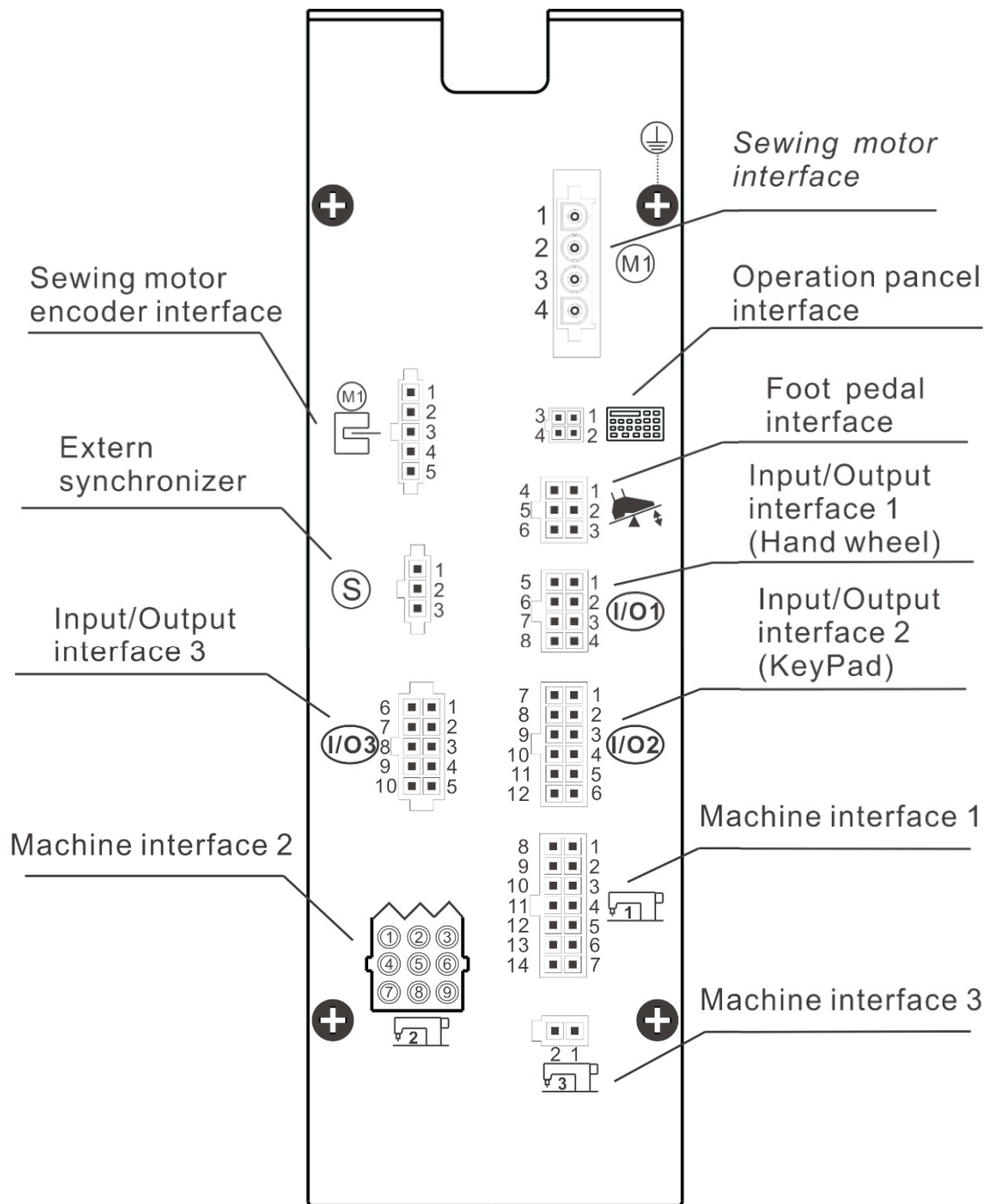

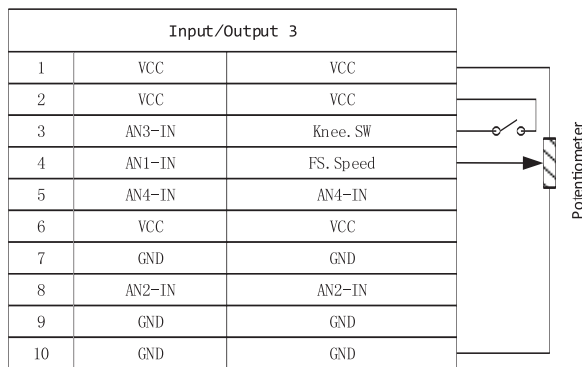
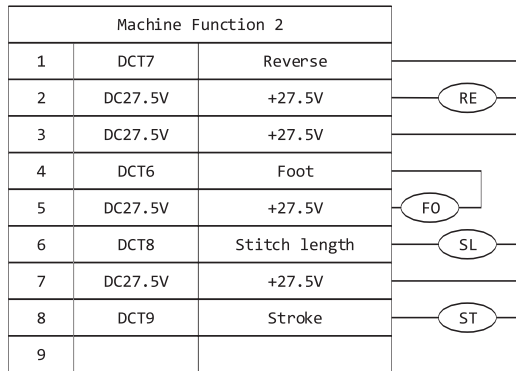
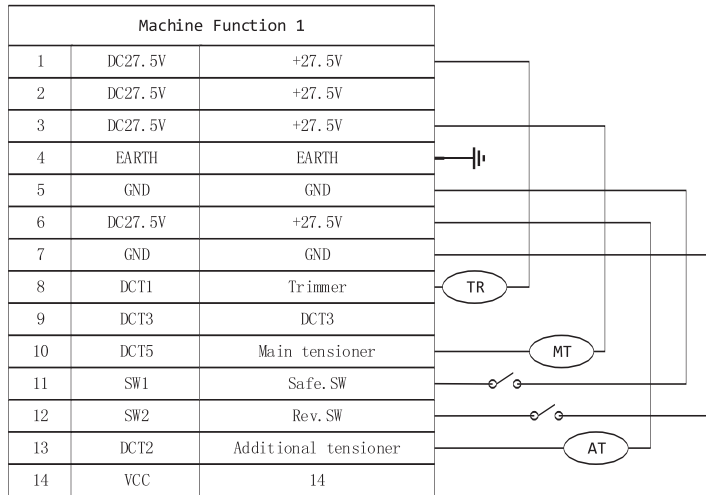

Encoder		Sewing motor	
1	DC-5V	1	EARTH
2	GNDS	2	A Phase
3	JT-UP	3	B Phase
4	MC-CHA	4	C Phase
5	MC-CHB		

Pance1	
1	VCC
2	GND
3	RXD21
4	TXD21

Foot Pedal	
1	IO3-IN
2	IO6-IN
3	IO2-IN
4	Pedal
5	GND
6	VCC

Keypad	
1	GND
2	GND
3	IO12-OUT
4	IO11-OUT
5	IO8-IN
6	VCC
7	IO1-IN
8	IO5-IN
9	IO4-IN
10	IO9-IN
11	IO10-OUT
12	VCC

Synchronizer	
1	VCC
2	JT-UP-A
3	GND

Hand wheel	
1	GND
2	GND
3	IO13-IN
4	IO7-IN
5	CHB-IN
6	CHA-IN
7	Z-IN
8	VCC

Machine Function 3	
1	DC27.5V
2	DCT4

Solenoid Abbreviations	
TR	Trimmer
MT	Main tensioner
AT	Additional tensioner
RE	Reverse
FO	Foot
SL	Stitch length
ST	Stroke
CL	Clamp