

GLOBAL

INDUSTRIAL SEWING MACHINES

MODEL BM-9352
BLINDSTITCH MACHINES

PARTS BOOK
INSTRUCTION MANUAL

INDEX

1. Unpacking Machine.....	1
2. Handwheel Rotation and Speed.....	1
3. Oiling and Maintenance.....	1
4. Replacing Needle.....	2
5. Threading Machine.....	2
6. Stitch Length Regulation.....	3
7. Adjustment of Thread Tension.....	3
8. Inserting the Work and Starting to Sew...	4
9. Adjustment of Needle Penetration	5
10. Adjustment of Needle Penetration on Cross Stitch Section.....	5

1. UNPACKING MACHINE

Unpack machine from its shipping box, making certain that you remove from box all component parts and accessories.

Do not disorder any packing material without prior scrutiny as to contents.

Clean from machine all greases, dirt, or dust.

Pay particular attention to area around the looper mechanism and looper.

2. HANDWHEEL ROTATION AND SPEED

Turn handwheel only in direction away from operator for clockwise rotation. Be sure that motor drive is wired up to obtain the same clockwise rotation. However, the recommended operating speed of a brand new machine is 1,200 stitches per minute. After a breaking-in period of several weeks and after the operator has become skilled in the operation of the machine, the speed can be increased upto 2,200 stitches per minute.

3. OILING AND MAINTENANCE (Fig 1 & Fig 2)

Drop oil of good quality at all points shown on the oiling chart Fig 1 & Fig 2 before operating machine every day. After oiling, wipe machine carefully to avoid soiling of the material. Be sure to depress knee lifter lever preventing damage to the needle and the feed dog and to operate machine without materials under the presser foot for 2 or 3 minutes.

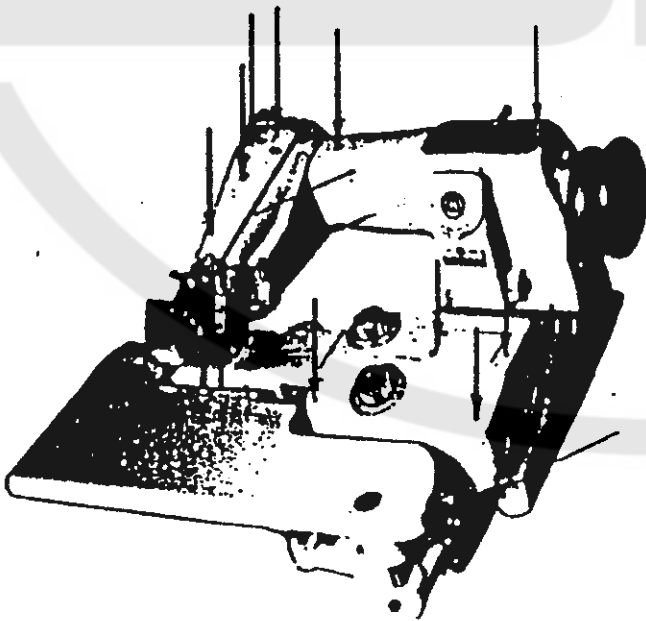

Fig. 1

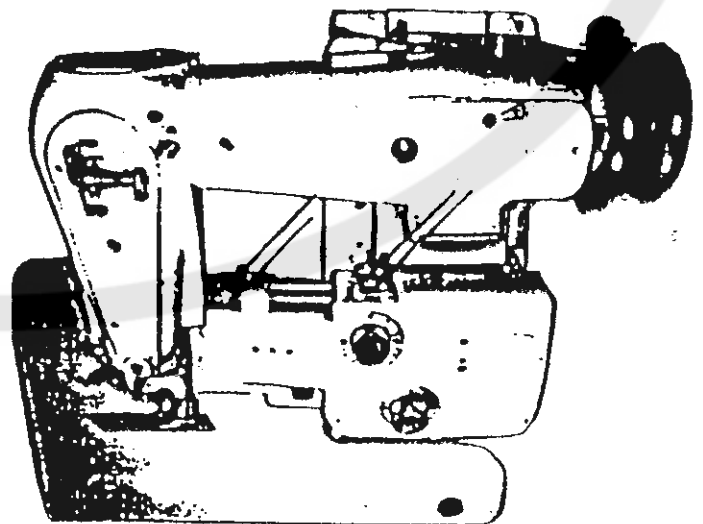
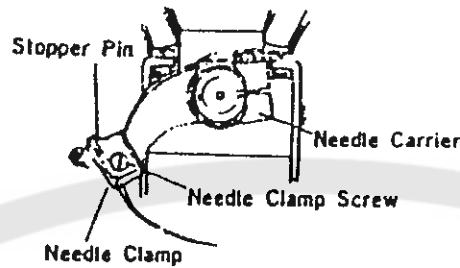

Fig. 2

4. REPLACING NEEDLE (Fig. 3)

Turn handwheel away from operator (clockwise) until needle reaches the end of its return stroke (Extreme left hand position), and adjust Disc Adjusting Dials in red and blue to least amount of penetration (Turn clockwise)

Remove old or defective needle by loosening needle clamp screw. Insert new needle into seat in Needle Clamp as far as it will go. Then, tighten needle clamp screw.



Turn handwheel slowly away from operator and observe movement of needle. The curved portion of the needle should bear slightly on the Needle Guide Groove in the left hand part of the Presser Foot. Always replace bent or blunt needles. They affect the satisfactory operation of the machine.

5. THREADING MACHINE

See threading chart Fig 3, Fig 4 and Fig 5.

Fig. 4

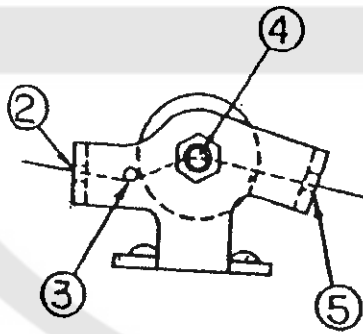

Fig. 3

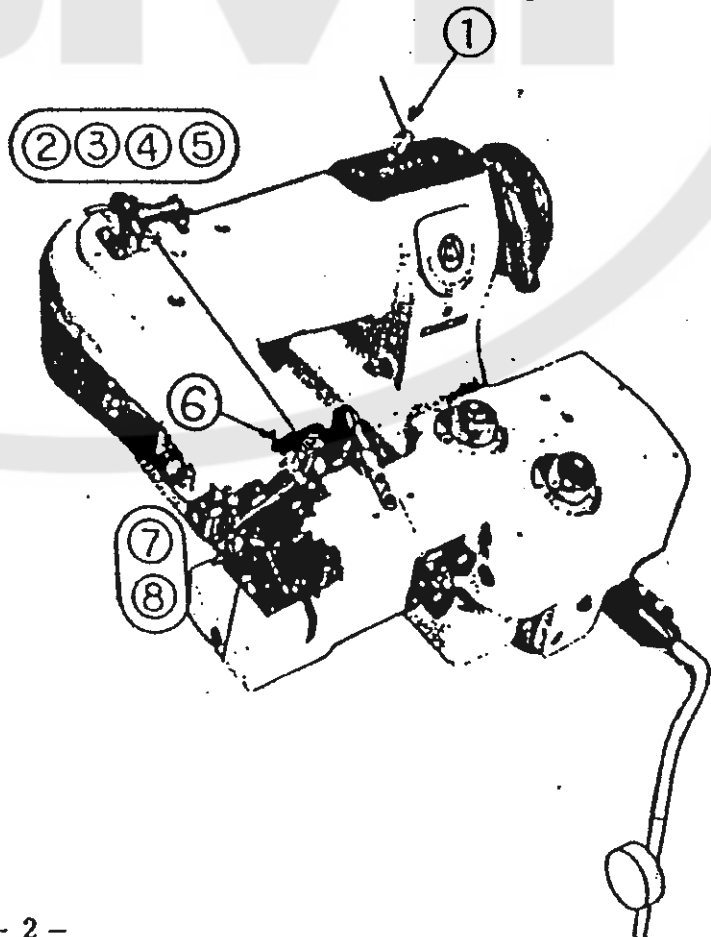
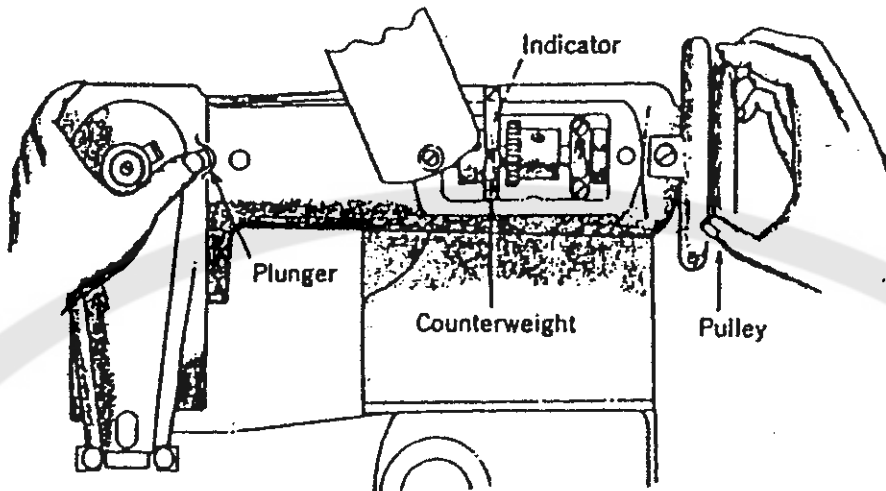

Fig. 5

6. STITCH LENGTH REGULATION

To adjust length of stitch, turn handwheel away from operator and at the same time depress the plunger located on top of the machine arm. As operator turns the handwheel, the plunger is felt to drop into a recess within the mechanism inside the machine.

With the plunger remaining depressed into this recess continue turning the handwheel either forward or backward until the desired number (3 to 8) will come into view in the small window to the left of the handwheel.



Each number represents a certain stitch as follows.

Number appearing on Indicator	3	4	5	6	7	8
Stitch Length (m/m)	8.5	6	5	4	3.5	3

A few trials with varied stitch lengths on different kinds of material will prove to be the best method for selection.

7. ADJUSTMENT OF THREAD TENSION

Different kinds and weights of material and the various sizes of thread require respective thread tensions. Thread tension is regulated by turning the Tension Nut located at the top of the machine arm.

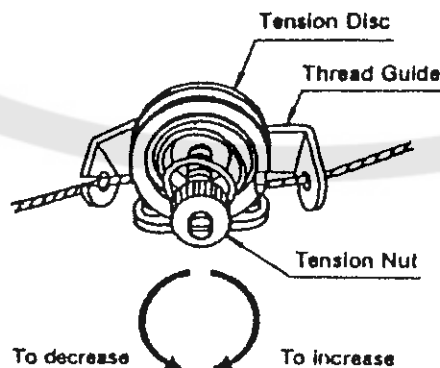

To increase thread tension, turn the nut away from you (clockwise).

To decrease the tension, turn the nut towards you (counter-clockwise).

Do not turn, tighten or loosen tension more than about one quarter turn at one time.

Test for results and readjust, if necessary.

8. INSERTING THE WORK AND STARTING TO SEW

Turn handwheel clockwise until needle reaches the end of its return stroke (extreme left hand position).

Fold the material as Fig 8 and depress knee lifter. This causes the Feed Plate to go downward to create a clearance between the Presser Foot and the Feed Plate.

Insert the material in the clearance just opened in such a manner that edge of the material is along side the edge of Guide (A) of the Presser Foot (see fig 8).

When the material is in proper position, completely release the knee lifter. Get the machine started slowly and watch the material pass edge guide rather than to observe the action of the needle.

In case of the material with piped hem, dettatch guide B, and insert the material as same manner as above.

Fig. 8

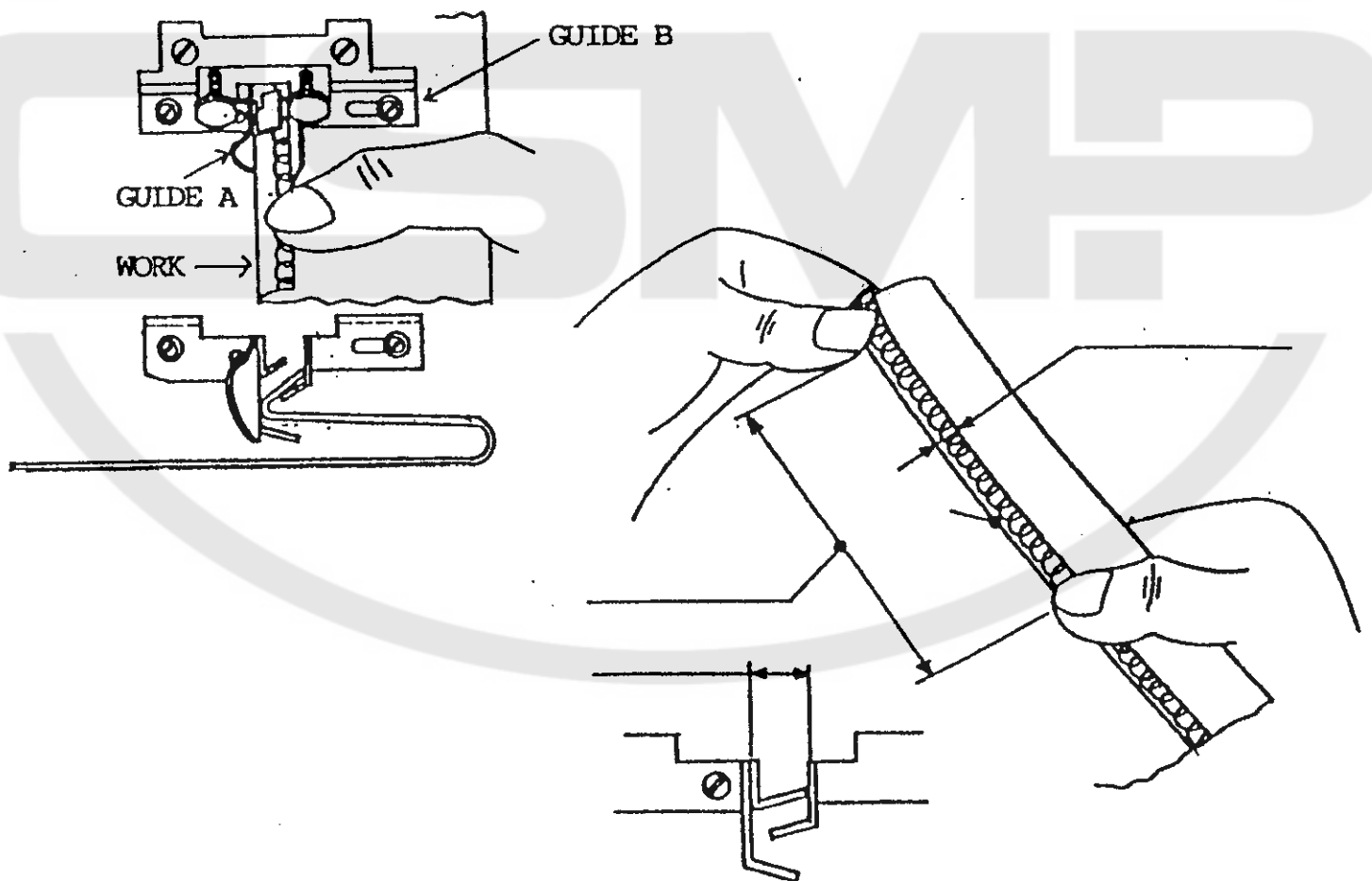

9. ADJUSTMENT OF NEEDLE PENETRATION

Desirable penetration can be obtained by Disc Adjusting Dial of blue colour for side A, and red colour for side B.

Turn Disc Adjusting Dials clockwise for less penetration and counter clockwise for more penetration.

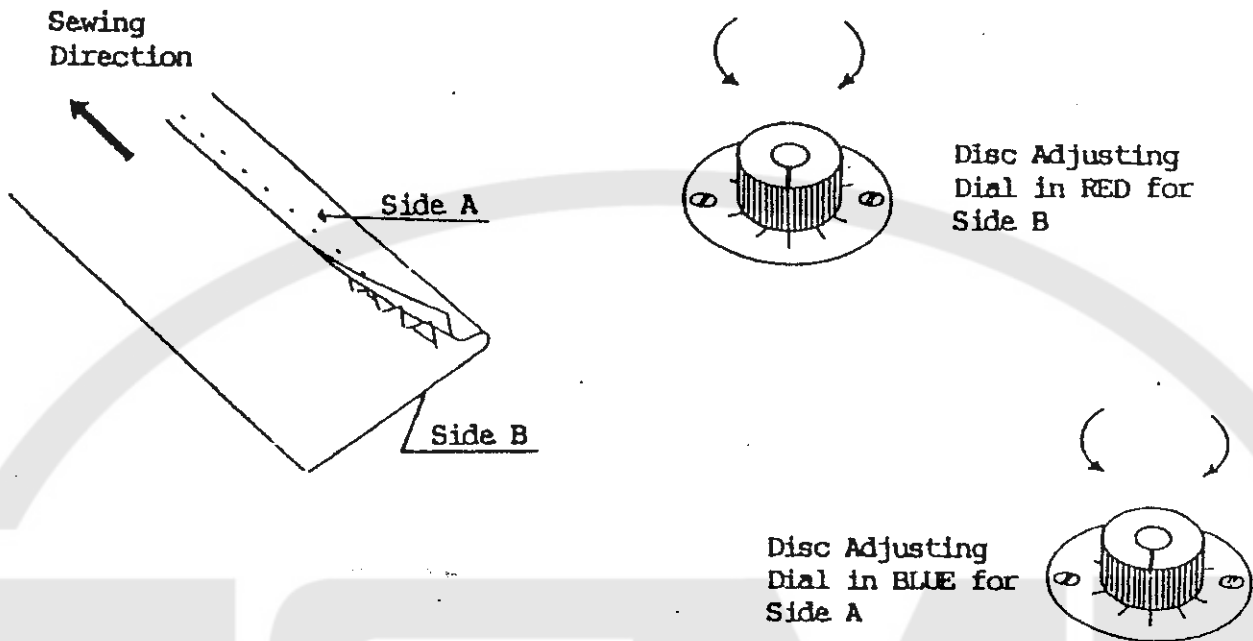

10. ADJUSTMENT OF NEEDLE PENETRATION ON CROSS SEAM SECTION

It is required to regulate the pressure of the Cloth Retainer to sew cross stitch section by adjusting Cloth Retainer Stop Screw of left side for side A, and right side for side B.

Turn Cloth Retainer Stop Screw clockwise for less penetration, and counter clockwise for more penetration.

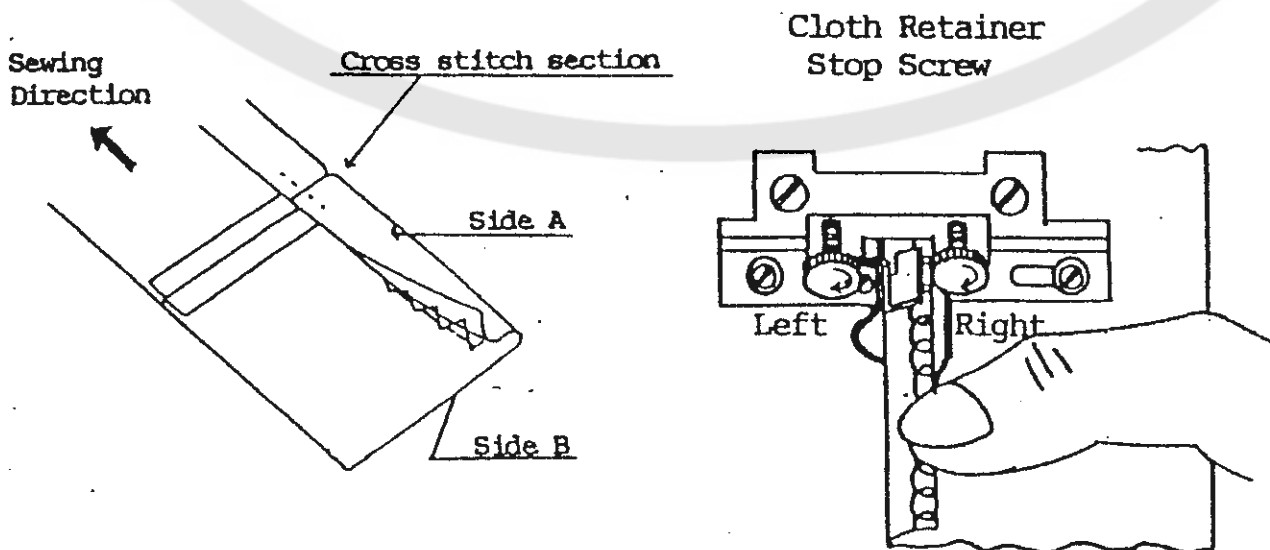

CONTENTS

	Page
Machine Frame, Thread Tention & Eye Guard Components	1
Main Shaft Mechanism Component	3
Needle Carrier & Feed Dog Mechanism Components	5
Looper Drive Mechanism & Presser Foot Parts Components	7
Feed Plate, Disc Adjusting Dial & Dial Cover	9
Spring Adjusting for Ridge Forming Disc Mechanism Components	11
Ridge Forming Disc for Right Mechanism Components	13
Ridge Forming Disc for Left Mechanism Components	15
Knee Press & Knee Press Shaft Parts Components	17
Work Plate & Belt Cover Parts Components	19
Option Parts for Original Complete Set	21
Option Parts for Original Complete Set	23
Standard Accessories	25

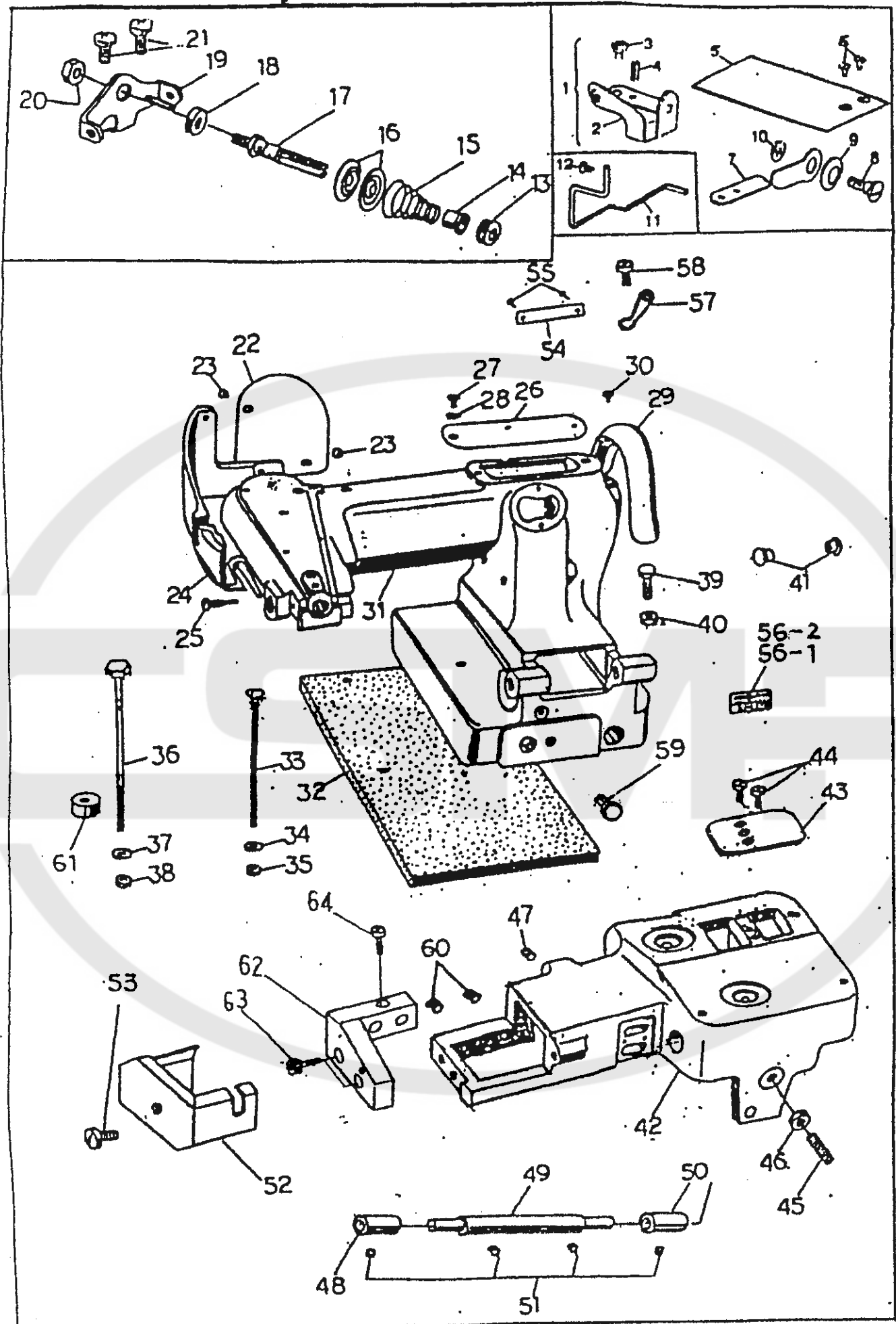

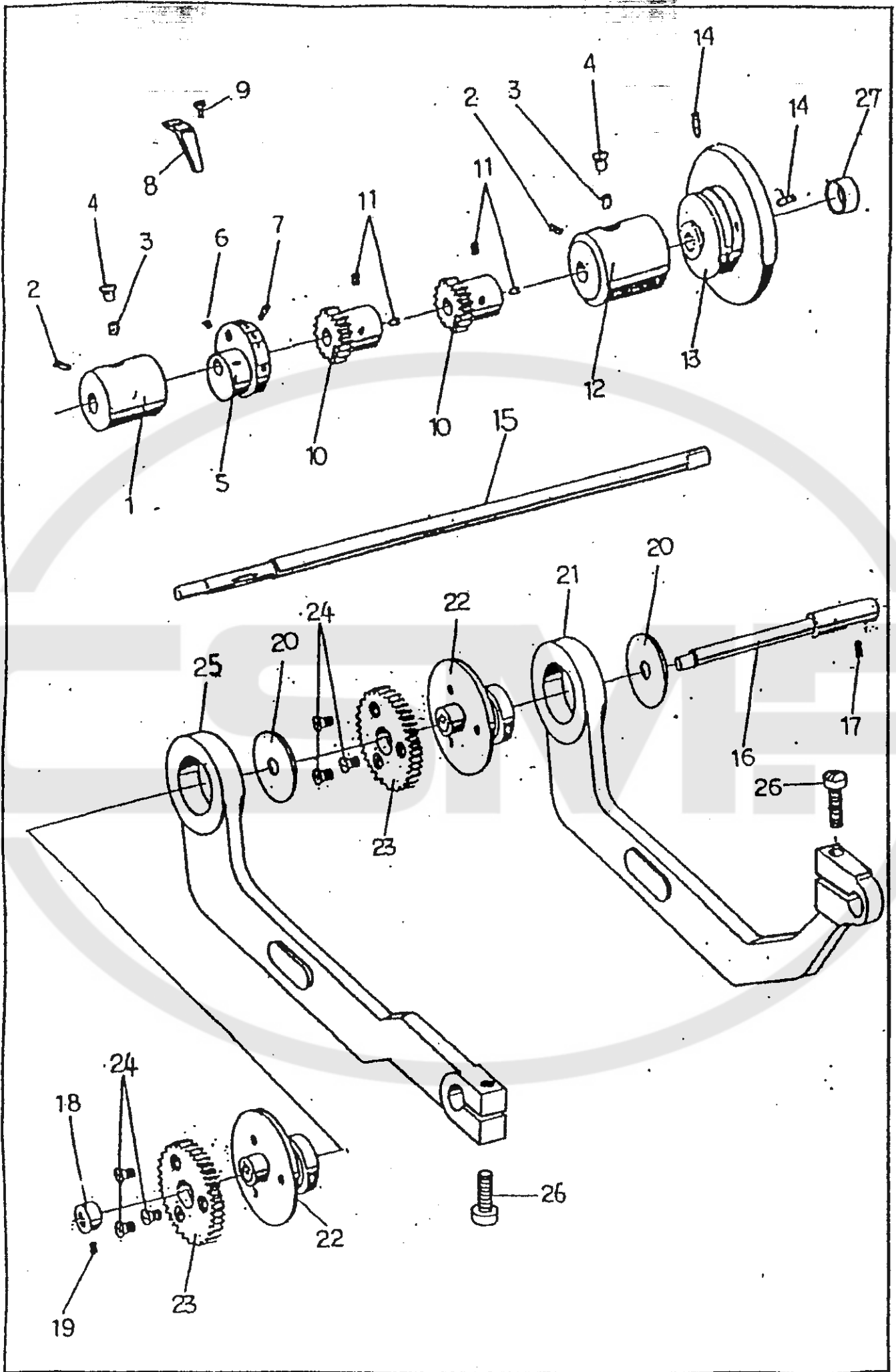

MAIN SHAFT MECHANISM COMPONENTS

REF NO.	Parts No.	Description
1	11005	Main Shaft Bushing (Left)
2	131	Screw
3	4217-A	Oiling Felt
4	4128-A	Oil Cap
5	4133	Counterweight (with Stitch Length Numbers)
6	132	Screw
7	98	Screw
8	4134	Stitch Length Indicator
9	124	Screw
10	4162-A	Small Gear
11	0096006	Screw
12	11006	Main Shaft Bushing (Right)
13	4142-B	Hand Wheel (Pulley)
14	131	Screw
15	4003-A	Main Shaft
16	21774	Gear Shaft
17	131	Screw
18	4077-A	Gear Shaft Collar
19	132	Screw
20	26563	Eccentric Rod Collar
21	21726-A	Eccentric Rod (High)
22	21732-A	Eccentric Bushing
23	4163-1	Main Shaft Gear(Large)
24	4163-3	Screw
25	21726-B	Eccentric Rod (Low)
26	114-A	Screw
27	4207-A	Hand Wheel Rubber Cap

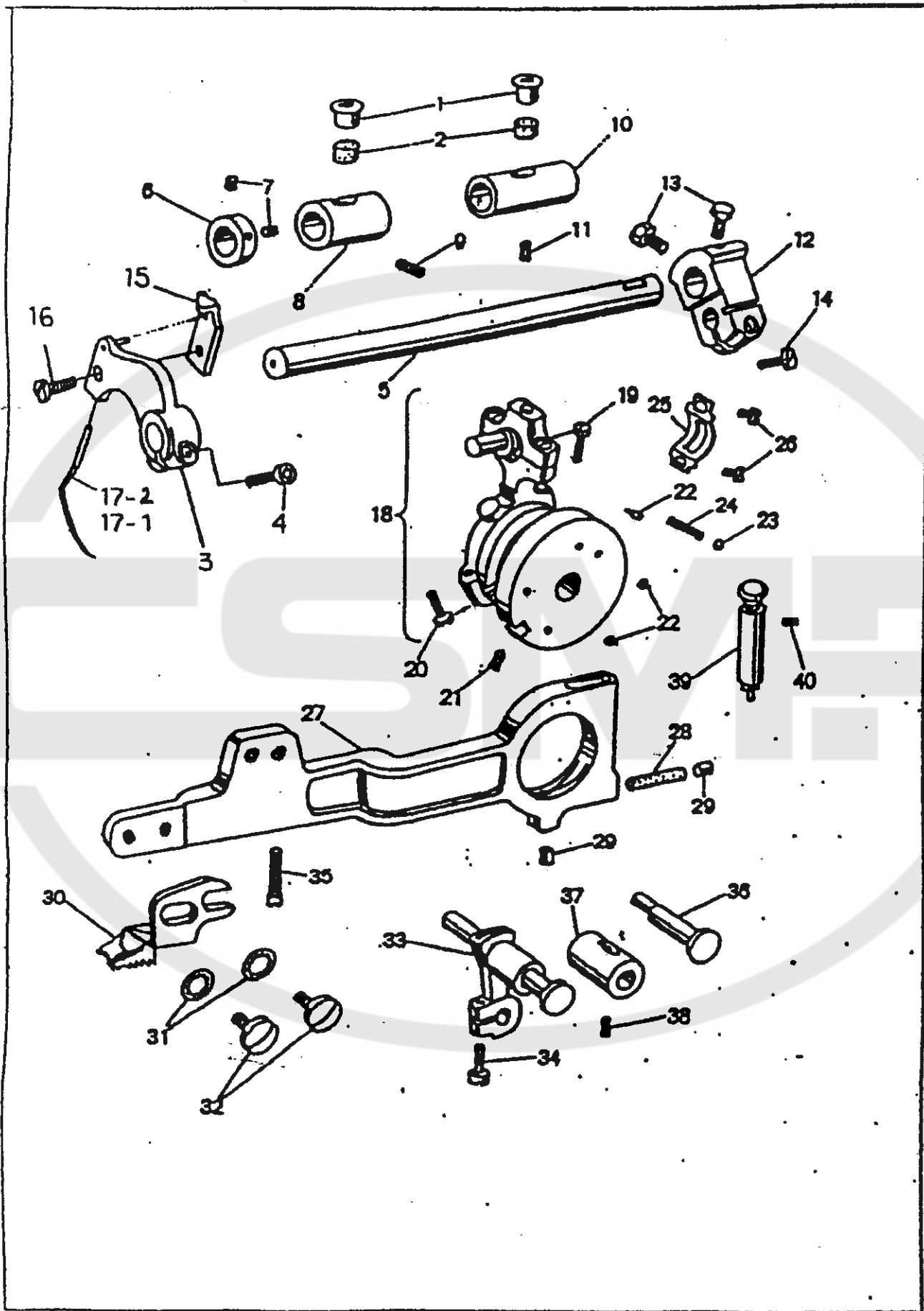

NEEDLE CARRIER & FEED DOG MECHANISM COMPONENTS

Ref No.	Parts No.	Description	Ref No.	Parts No.	Description
1	4128-A	Arm Top Oil Cap	31	2528	Washer
2	5217-A	Screw	32	4048-A	Screw
3	17026-G	Needle Carrier	33	1152-AA	Feed Link & Stud
4	17144	Screw	34	4173	Screw
5	4019	Needle Carrier Shaft	35	0095016	Screw
6	4022	Needle Carrier Shaft Collar	36	4044	Eccentric Pin
7	129-B	Screw	37	4043	Bushing
8	11032	Needle Carrier Bushing (Front)	38	129-A	Screw
9	129-A	Screw	39	520-A	Stitch Length- Regulating Plunger
10	11033	Needle Carrier Bushing (Rear)			
11	129-A	Screw	40	129-A	Screw
12	4017-A	Needle Carrier Shaft Crank			
13	4018-C	Screw			
14	114-A	Screw			
15	17027-G	Needle Clamp			
16	17145	Screw			
17-1	21790-G1	Groz Needle #80			
17-2	21790-G2	Groz Needle #70			
18	1151-B	Needle Driving Eccentric Assy.			
19	0214012	Screw			
20	0214016	Screw			
21	4009-B	Screw			
22	4012-A	Screw			
23	4010	Stitch Regulator Ball			
24	4011-A	Stitch Regulator Spring			
25	4014	Ball Connecting Rod Cap			
26	4015	Screw			
27	11902-A	Feed Lever			
28	11124-J	Oiling Felt			
29	11121	Feed Lever Cap			
30	21730	Feed Dog			

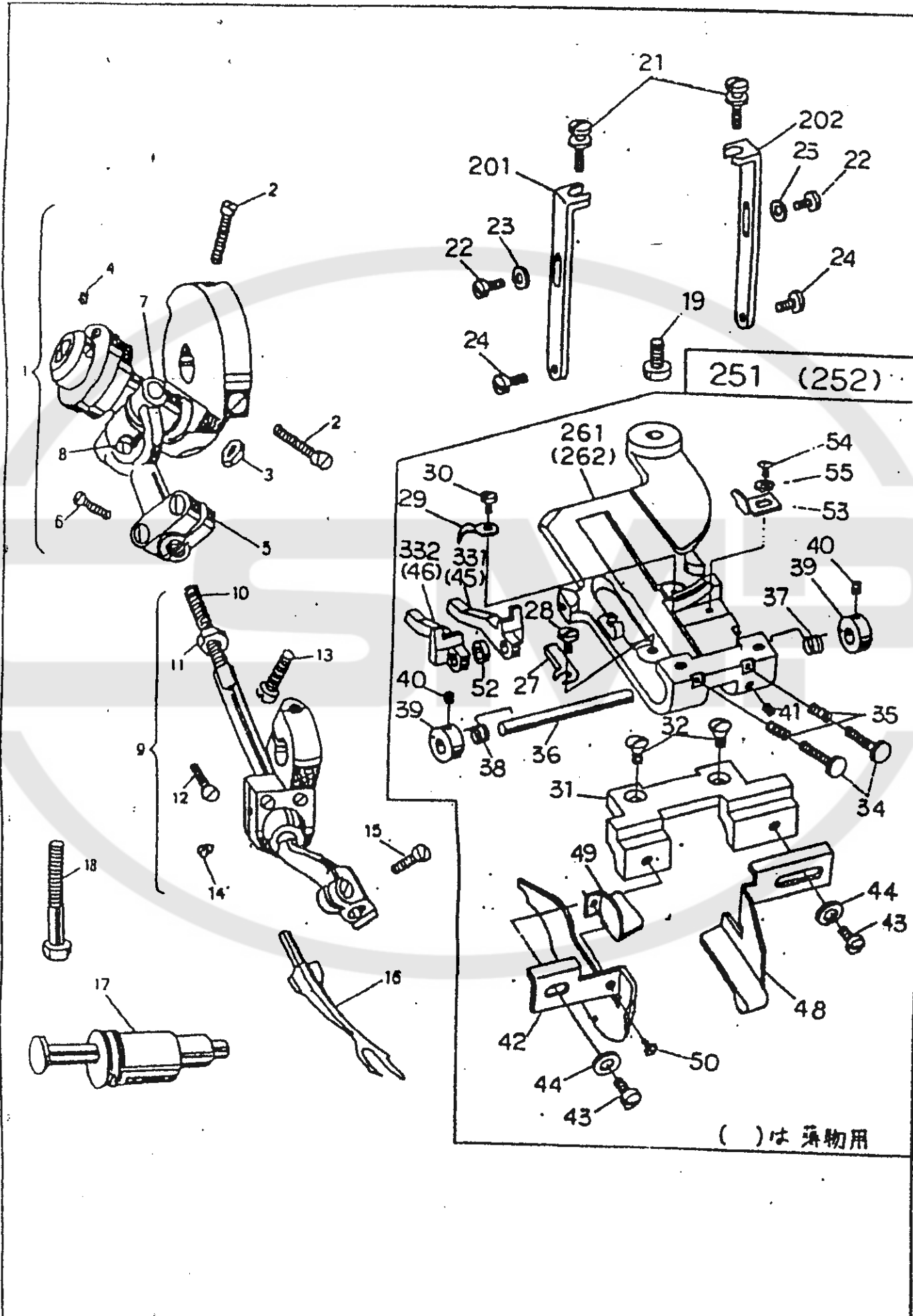

NEEDLE CARRIER & FEED DOG MECHANISM COMPONENTS

Ref No.	Parts No.	Description	Ref No.	Parts No.	Description
1	538-B	Looper Drive Crank Complete (Ref.Nos.2-8)	29	21770	Chaining Finger
2	4191	Screw	30	4185-B	Screw
3	5039-A	Nut	31	21708-C	Edge Guide Bracket
4	129-B	Screw	32	11152	Screw
5	4030-A	Looper Yoke	33-1	21706-1B	Cloth Retainer (R)
6	4031	Screw	33-2	21706-2B	Cloth Retainer (L)
7	4032-A	Looper Yoke Pin	34	21768-A	Cloth Retainer Stopper Screw
8	8142	Screw	35	7039-B	Cloth Retainer Adjusting Notch
9	539-A	Looper Carrier Complete (Ref.Nos.10-15)	36	21711-A	Cloth Retainer Pin
10	4035-A	Looper Carrier	37	21709-BA	Cloth Retainer Spring (Right)
11	4176	Nut	38	21710-B	Cloth Retainer Spring (Left)
12	4216	Screw	39	21712-A	Cloth Retainer Collar
13	4213	Screw	40	4183	Screw
14	4179-D	Screw	41	0093004	Screw
15	4040	Screw	42	21707-F	Edge Guide
16	11837	Looper	43	4015	Screw
17	505	Eccentric Sleeve Pin	44	0400308	Washer
18	4038	Screw	45	21739-D	Cloth Retainer (R)
19	4050	Screw	46	21740-D	Cloth Retainer (L)
20-1	4061-A	Presser Foot Bracket (Left)	48	21761-B	Cloth Guide
20-2	4061-B	Presser Foot Bracket (Right)	49	21762-A	Cloth Guide Upper Plate
21	4062	Screw	50	4185-B	Screw
22	121-B	Screw	52	21769	Spacer
23	11158	Washer	53	22253-A	Drop Stitch Prevention Plate
24	4186-A	Screw	54	4185-B	Screw
25-1	PF-1190-1A	Presser Foot Complete	55	4220	Washer
25-2	PF-1190-2A	Presser Foot Complete			
26-1	21705-1A	Plain Presser Foot			
26-2	21705-2A	Plain Presser Foot			
27	11563	Needle Guide			
28	4052-B	Screw			

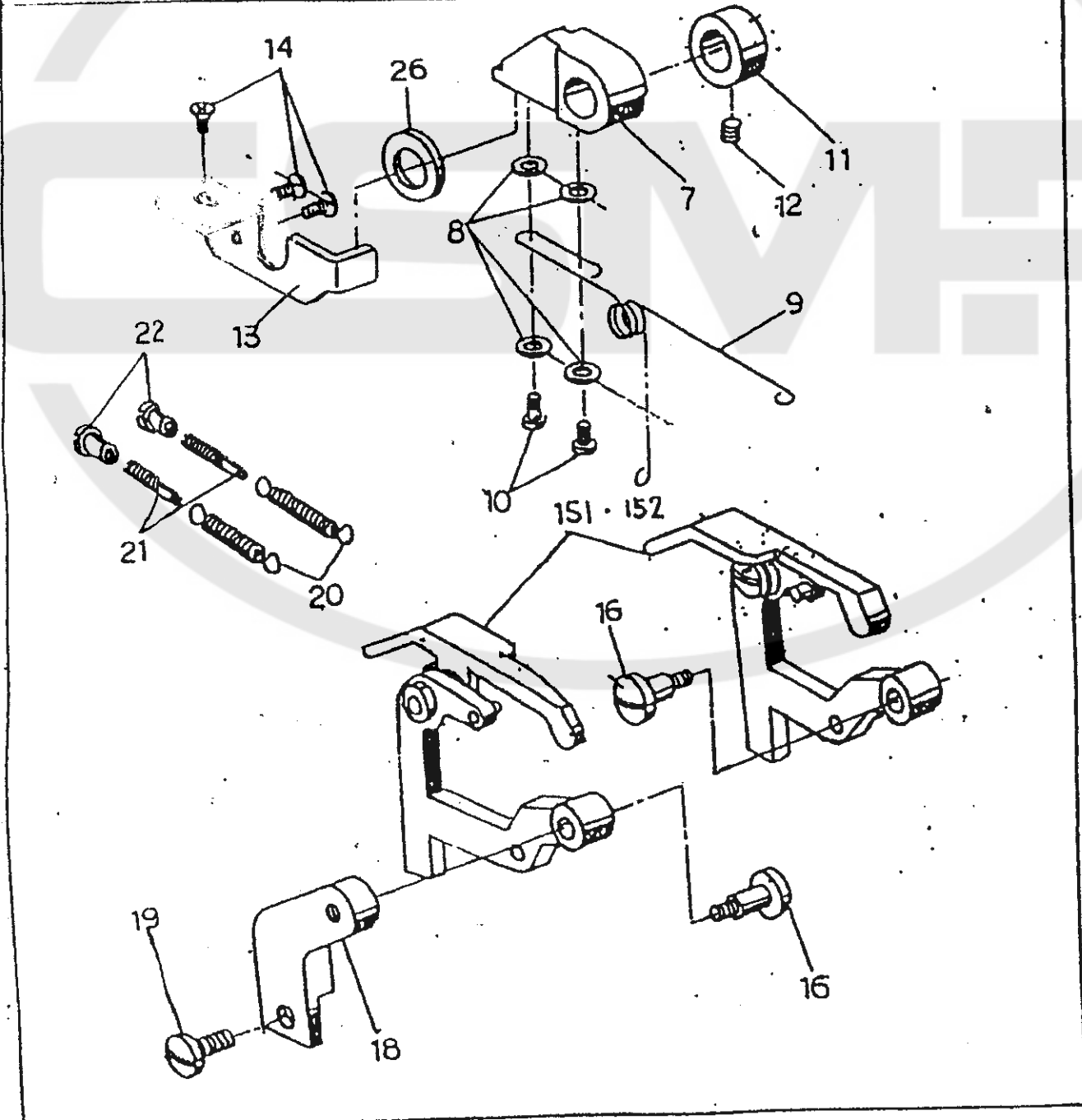
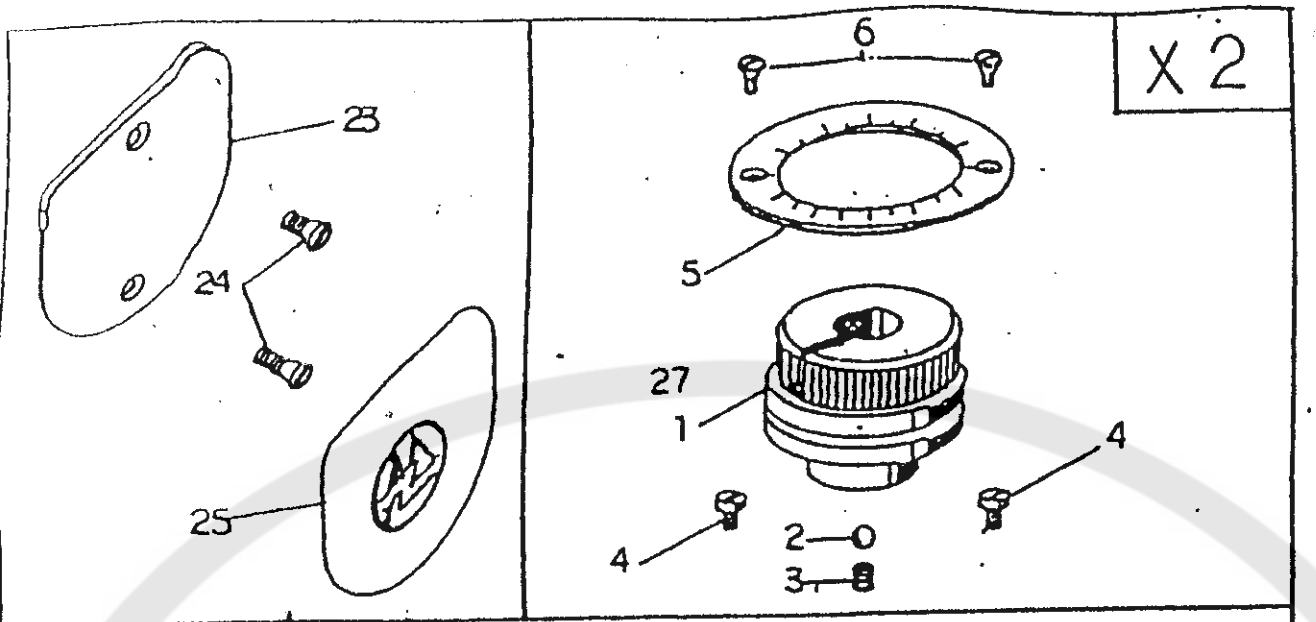

FEED PLATE, DISC ADJUSTING DIAL & DIAL COVER COMPONENTS

REF NO.	Parts No.	Description
1	519-GT	Disc Adjusting Regulator Complete
2	4010	Ball
3	10052	Spring
4	115	Screw
5	22241-A	Disc Adjusting Dial
6	5191	Screw
7	26547-C	Dial Block
8	0400308	Washer
9	26548-B	Dial Block Spring
10	0143005	Screw
11	26549	Dial Block Collar
12	132	Screw
13	26562-A	Dial Plate
14	0153008	Screw
15-1	S-516-H1	Feed Plate Complete for 1190-1
15-2	S-516-H2	Feed Plate Complete for 1190-2
16	26611	Screw
18	21715	Feed Plate Bracket
19	4048-A	Screw
20	4093-B	Feed Plate Spring
21	4094	Screw
22	4095	Feed Plate Spring Adjusting Nut
23	4653-A	Dial Cover
24	8333	Screw
25	4653-2A	Logo Mark Plate
26	5224-A	Washer

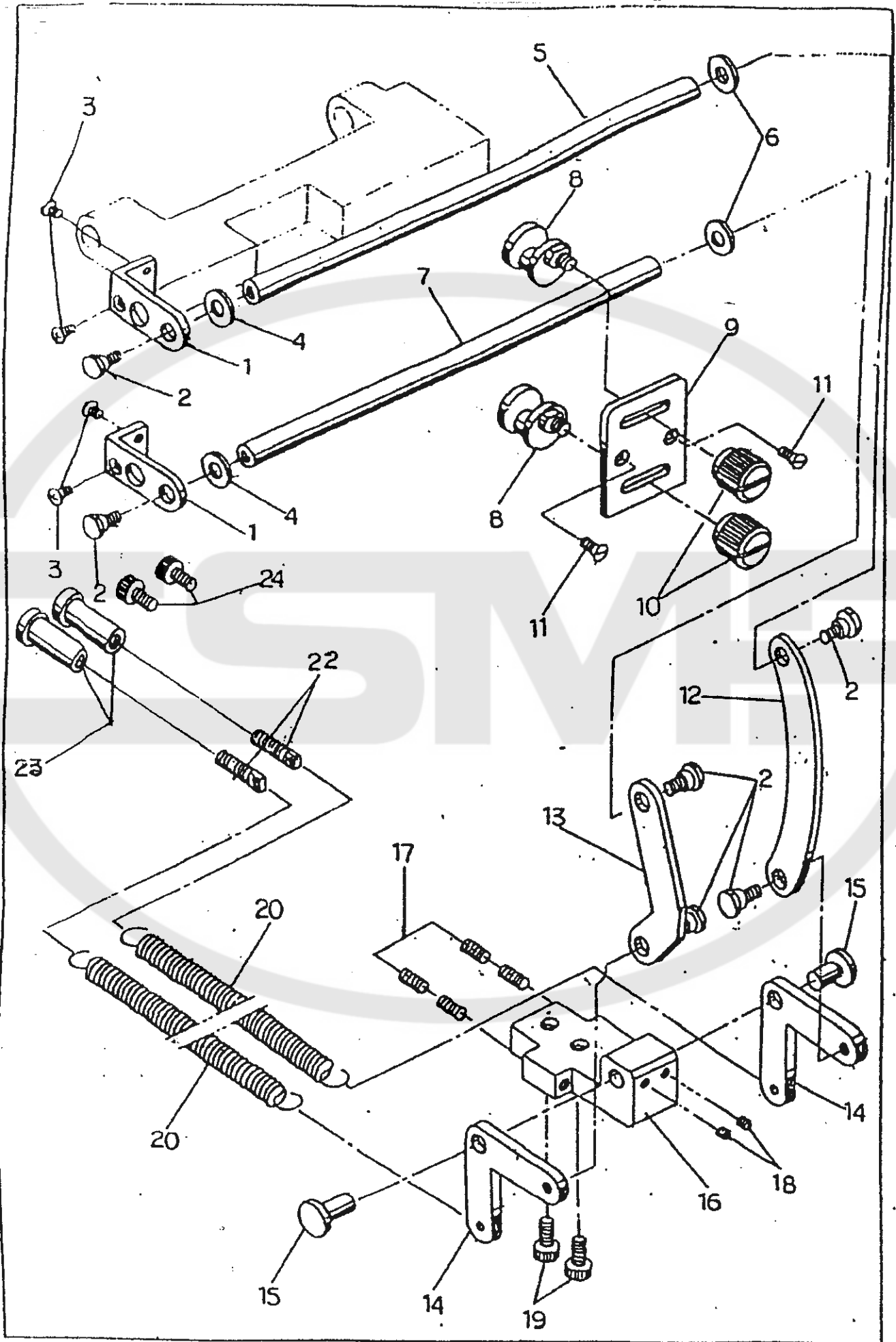

SPRING ADJUSTING FOR RIDGE FORMING DISC MECHANISM COMPONENTS

REF NO.	Parts No.	Description
1	26518	Disc Adjusting Holder Plate
2	26528	Screw
3	0153008	Screw
4	11158	Washer
5	26523-A	Spring Adjusting Lever A
6	1158	Washer
7	26524-A	Spring Adjusting Lever B
8	26551-A	Spring Adjusting Shifter
9	26552	Spring Adjusting Plate
10	26550-A	Spring Adjusting Dial
11	7095-A	Screw
12	26526	Spring Adjusting Link B
13	21759	Spring Adjusting Link A
14	26527-A	Spring Adjusting Link C
15	26564	Spring Adjusting Link Pin
16	26561	Plunger Spring Link Block
17	0095020	Screw
18	0094006	Screw
19	0215012	Screw
20	4073-T	Spring
22	4074	Spring Adjusting Screw
23	4075	Spring Adjusting Nut
24	0216016	Bolt

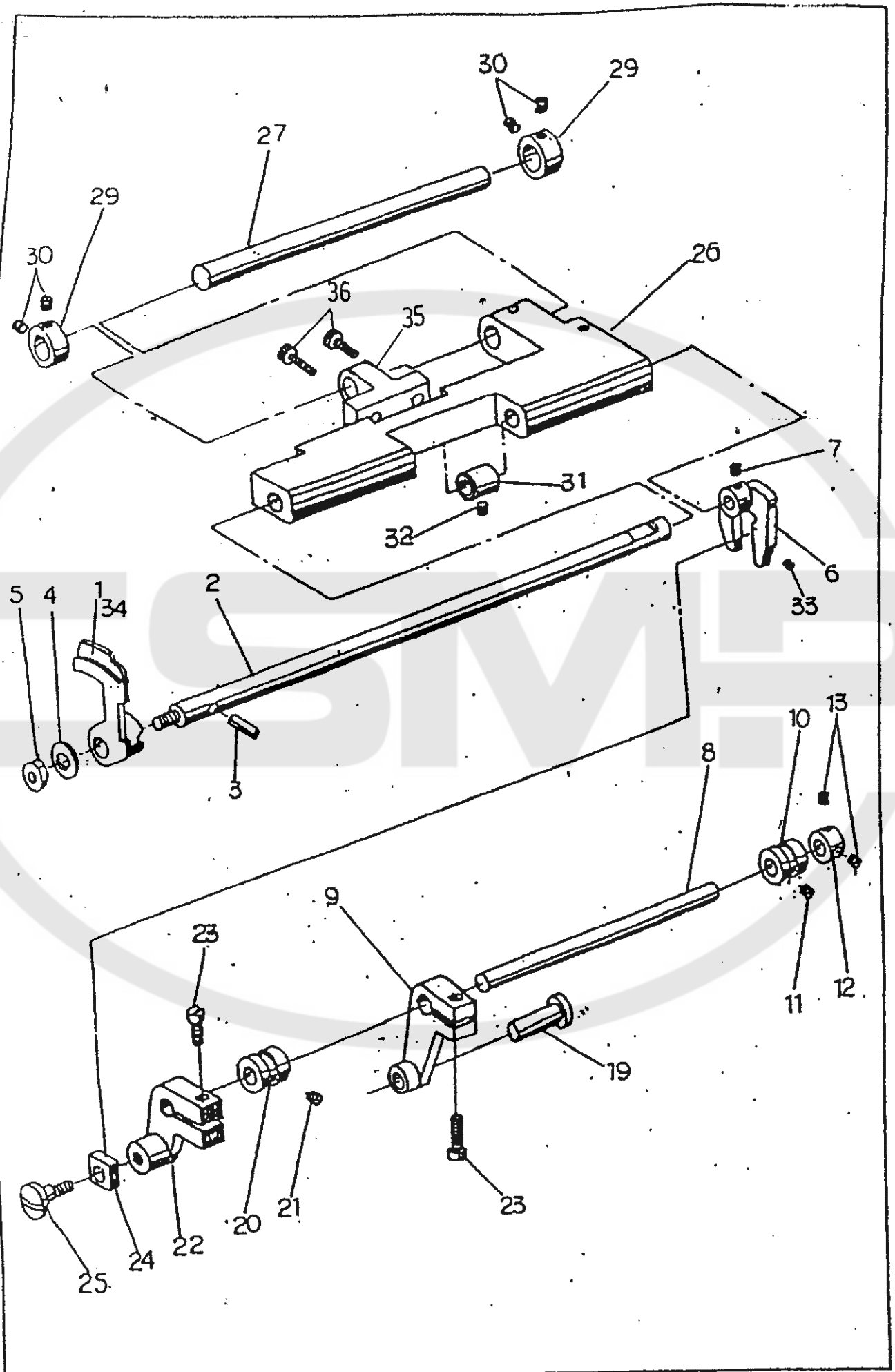

RIDGE FORMING DISC FOR RIGHT COMPONENTS

REF NO.	Parts No.	Description
1	21703-A	Ridge Forming Disc (Right)
2	26521-A	Ridge Forming Disc Shaft B
3	8150	Ridge Forming Disc Position Pin
4	5222-B	Ridge Forming Disc Washer
5	4208	Ridge Forming Disc Nut (Left)
6	26530-C	Ridge Forming Disc Shaft Link
7	0094006	Screw
8	26535-B	Ridge Forming Disc Driving Shaft
9	26529-B	Eccenmtric Rod (Low) Lever
10	26538-A	Ridge Forming Disc Driving Shaft Bushing
11	129-A	Screw
12	10017-A	Ridge Forming Disc Driving Shaft Collar
13	17147-T	Screw
19	21773	Driving Shaft Lever Pin
20	26538-A	Driving Shaft Bushing
21	129-A	Screw
22	26529-A	Slider Link A
23	26543	Screw
24	11808	Slider
25	26533-A	Screw
26	21751-H1	Disc Adjusting Holder B
27	26522-H	Disc Adjusting Holder Shaft
29	17037	Disc Adjusting Holder Shaft Collar
30	17146	Bolt
31	26545	Ridge Forming Disc Shaft Collar
32	129-B	Screw
33	0094006	Screw
34	21776	Ridge Forming Disc (Right)
35	21750-H2	Ridge Forming Disc Adjusting Block
36	0215010	Bolt

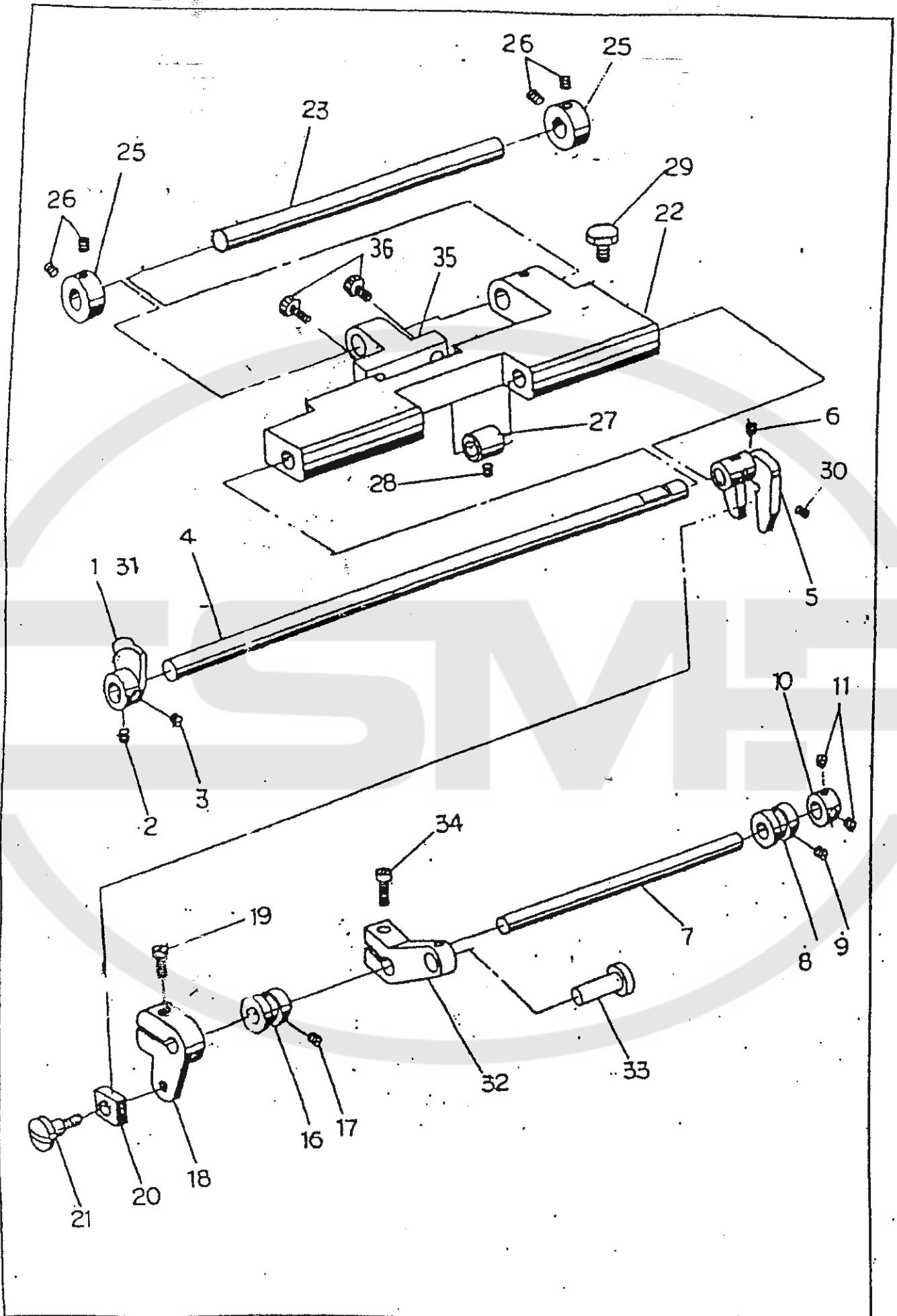

RIDGE FORMING DISC FOR LEFT MECHANISM COMPONENTS

REF NO.	Parts No.	Description
1	21704-A	Ridge Forming Disc (Left)
2	0084006	Screw
3	0094006	Screw
4	26520-B	Ridge Forming Disc Shaft (Left)
5	26532-C	Slider Link (Left)
6	0094006	Screw
7	26534-C	Driving Shaft
8	26538-A	Driving Shaft Bushing A
9	129-A	Screw
10	10017-A	Collar
11	17147-T	Screw
16	26538-A	Driving Shaft Bushing A
17	129-A	Screw
18	26531-B	Slider Link
19	26542	Screw
20	11808	Slider
21	26533-A	Screw
22	21750-H1	Disc Adjusting Holder A
23	26522-H	Disc Adjusting Holder Shaft
25	17037	Disc Adjusting Holder Shaft Collar
26	17146	Bolt
27	26545	Ridge Forming Disc Shaft Collar
28	129-B	Screw
29	26579	Disc Adjusting Holder A Stopper
30	0094006	Screw
31	21775	Ridge Forming Disc (Left)
32	21745-A	Eccentric Rod (High) Lever
33	21773	Eccentric Rod Lever Pin
34	26542	Screw
35	21750-H2	Ridge Forming Disc Adjusting Block
36	0215010	Bolt

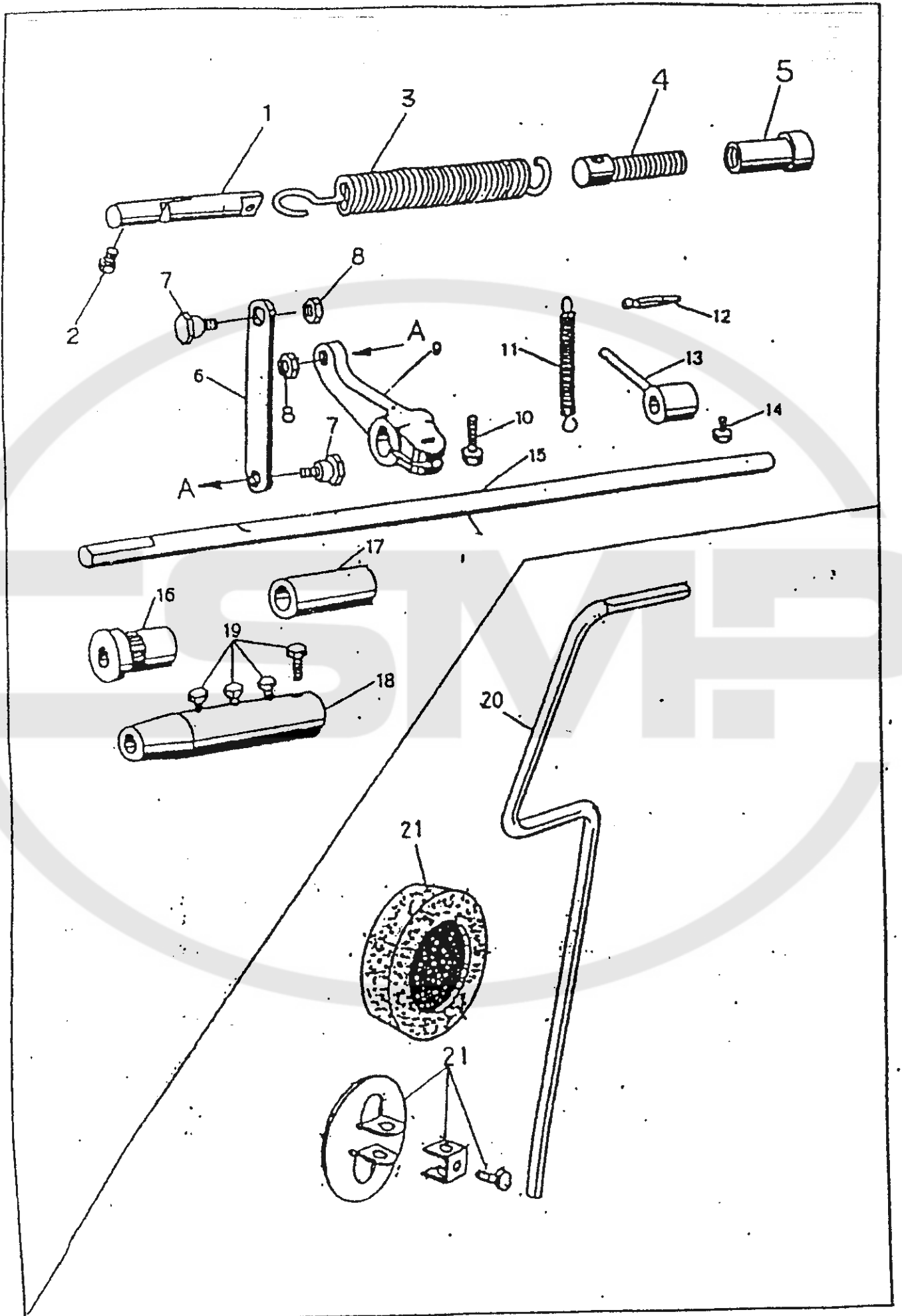

KNEE PRESS & KNEE PRESS SHAFT PARTS COMPONENTS

REF NO.	Parts No.	Description
1	26653-S	Machine Base Spring Joint
2	108	Screw
3	26628-T	Machine Base Spring
4	4535	Screw
5	4075	Screw Nut (Large)
6	4539	Machine Base Plate
7	4085-B	Screw
8	5207	Nut
9	21724-A	Knee Press Lever
10	4555	Bolt
11	4082	Spring
12	4116	Knee Shaft Spring Pin
13	4080-A	Spring Collar
14	4184	Bolt
15	11063-A	Knee Press Shaft
16	4081	Knee Press Shaft Bushing
17	4177	Knee Press Shaft Sleeve
18	4146-B	Knee Press Shaft Sleeve
19	4147-C	Bolt
20	4148-B	Knee Press Rod
21	S-21088	Knee Press Pad Set

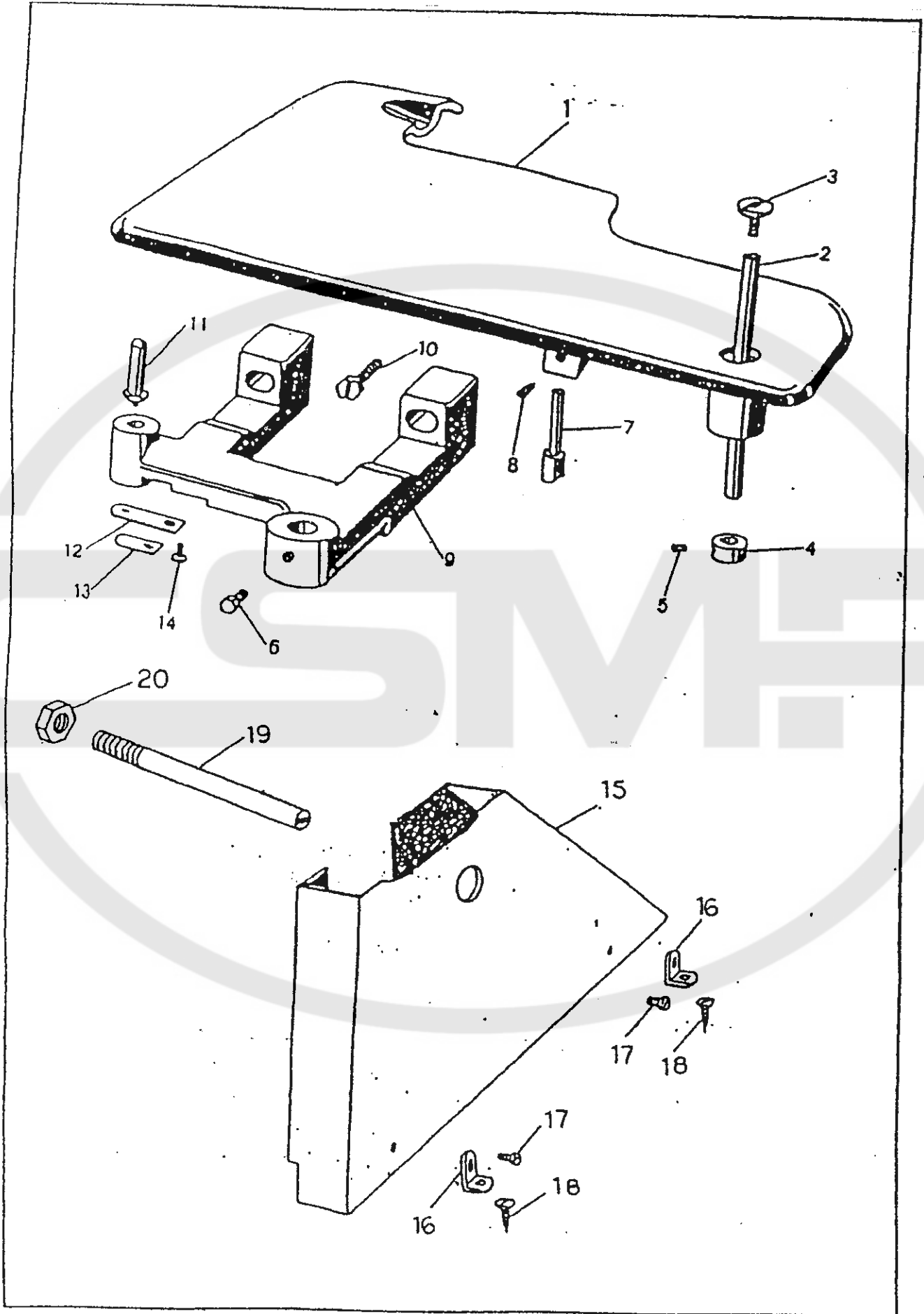

WORK PLATE & BELT COVER PARTS COMPONENTS

REF NO.	Parts No.	Description
1	26566	Work Plate
2	4154-A	Work Plate Shaft
3	99-A	Screw
4	4155	Work Plate Shaft Collar
5	132	Screw
6	4180	Bolt
7	4156	Work Plate Latch
8	5230	Screw
9	4542	Work Plate Bracket
10	4158	Bolt
11	4159	Work Plate Bracket Spring Pin
12	4160	Work Plate Bracket Leaf Spring (Long)
13	4161	Work Plate Bracket Leaf Spring (Short)
14	4048-A	Screw
15	4219-A	Belt Cover
16	11554	Belt Cover Bracket
17	5233	Screw
18	11557	Wood Screw
19	6107	Needle Positioner Positioning Screw
20	4068-A	Nut

OPTION

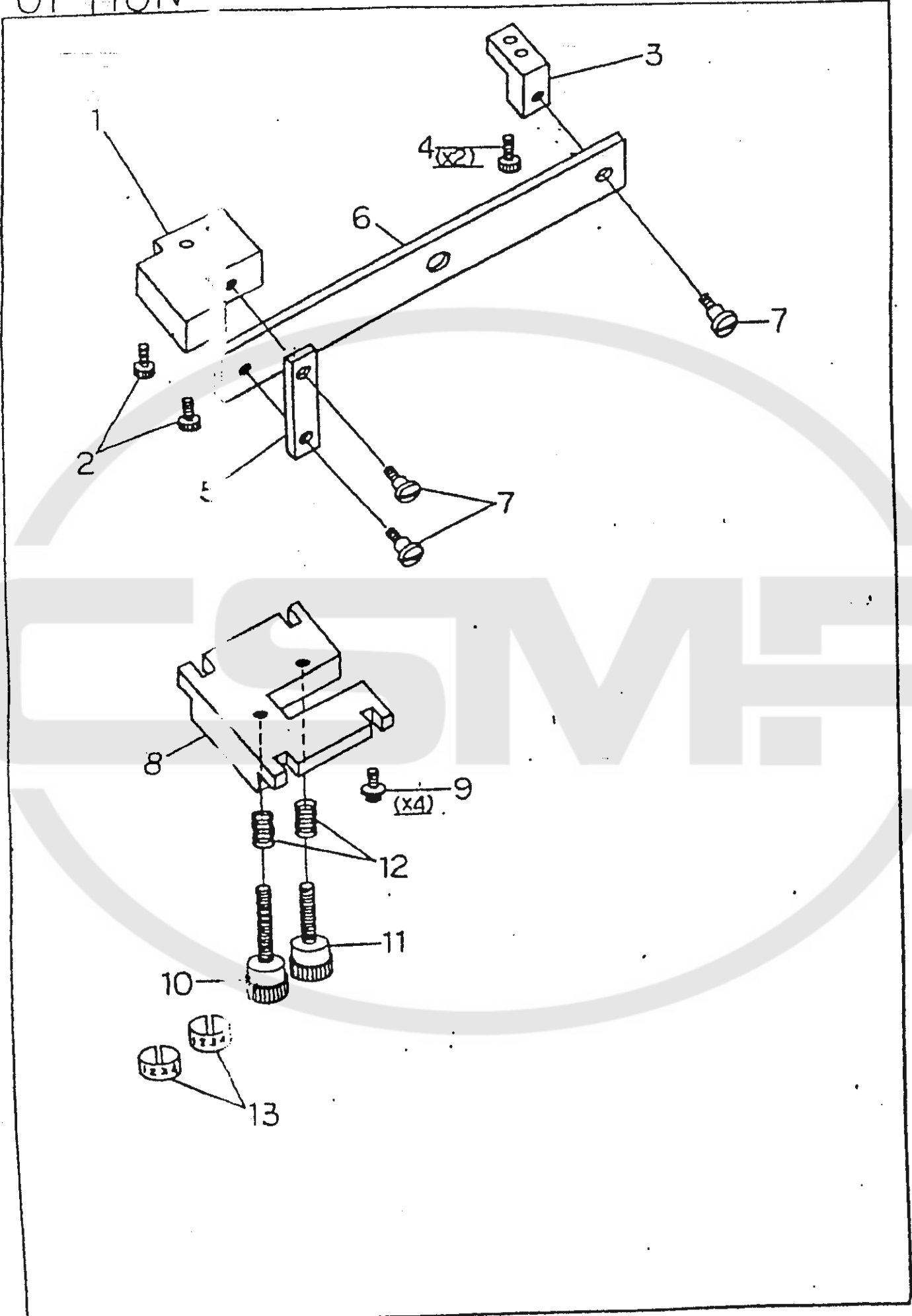

OPTION PARTS FOR ORIGINAL COMPLETE SET

REF NO.	Parts No.	Description
1	21752-H	Disc Adjusting Holder A Block
2	0214008	Bolt
3	21753	Disc Adjusting Holder B Block
4	0214008	Bolt
5	21754	Plunger Dropper Link Plate
6	21755	Plunger Dropper Lever
7	5179	Screw
8	21756	Plunger Dropper Adjusting Block
9	5739	Bolt
10	21757-A	Plunger Dropper Adjusting Screw A
11	21758-A	Plunger Dropper Adjusting Screw B
12	8103	Spring
13	11383-2	Plunger Dropper Regulating Mark

CSTMP

OPTION

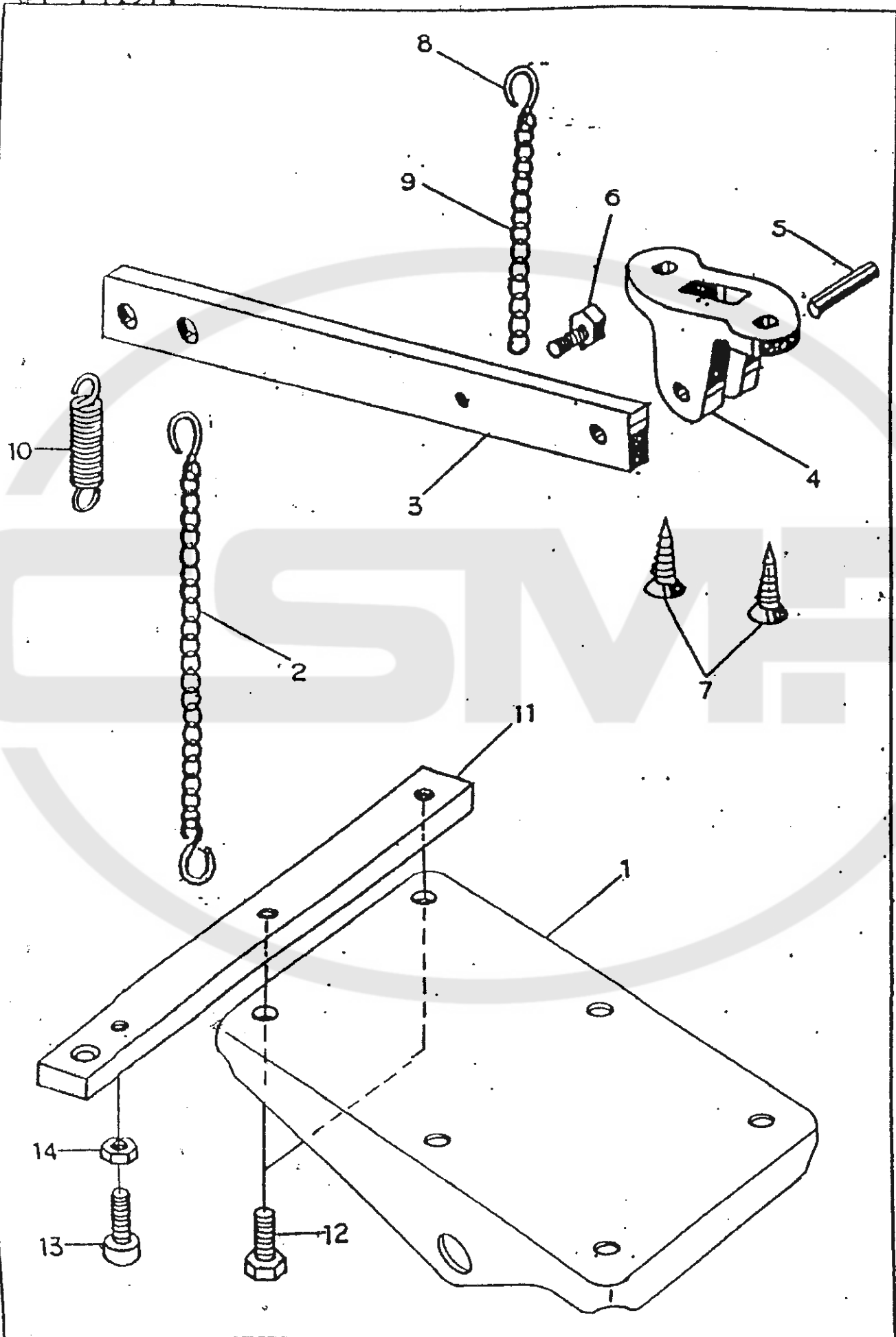

OPTION PARTS FOR ORIGINAL COMPLETE SET

REF NO.	Parts No.	Description
1	7257-A	Foot Pedal
2	7249-A	Foot Pedal Chain (Long)
3	26651	Foot Pedal Lever
4	7228-2	Foot Pedal Lever Block
5	7247	Foot Pedal Lever Pin
6	7108	Foot Pedal Chain Set Screw
7	AC-10A	Wood Screw
8	7269	S-Shaped Hook
9	7249-B	Foot Pedal Chain (Short)
10	5137-C	Foot Pedal Lever Spring
11	21763-A	Plunger Dropper Pedal Link Bar
12	0208012	Bolt
13	0148030	Screw
14	0308013	Nut

CSMP

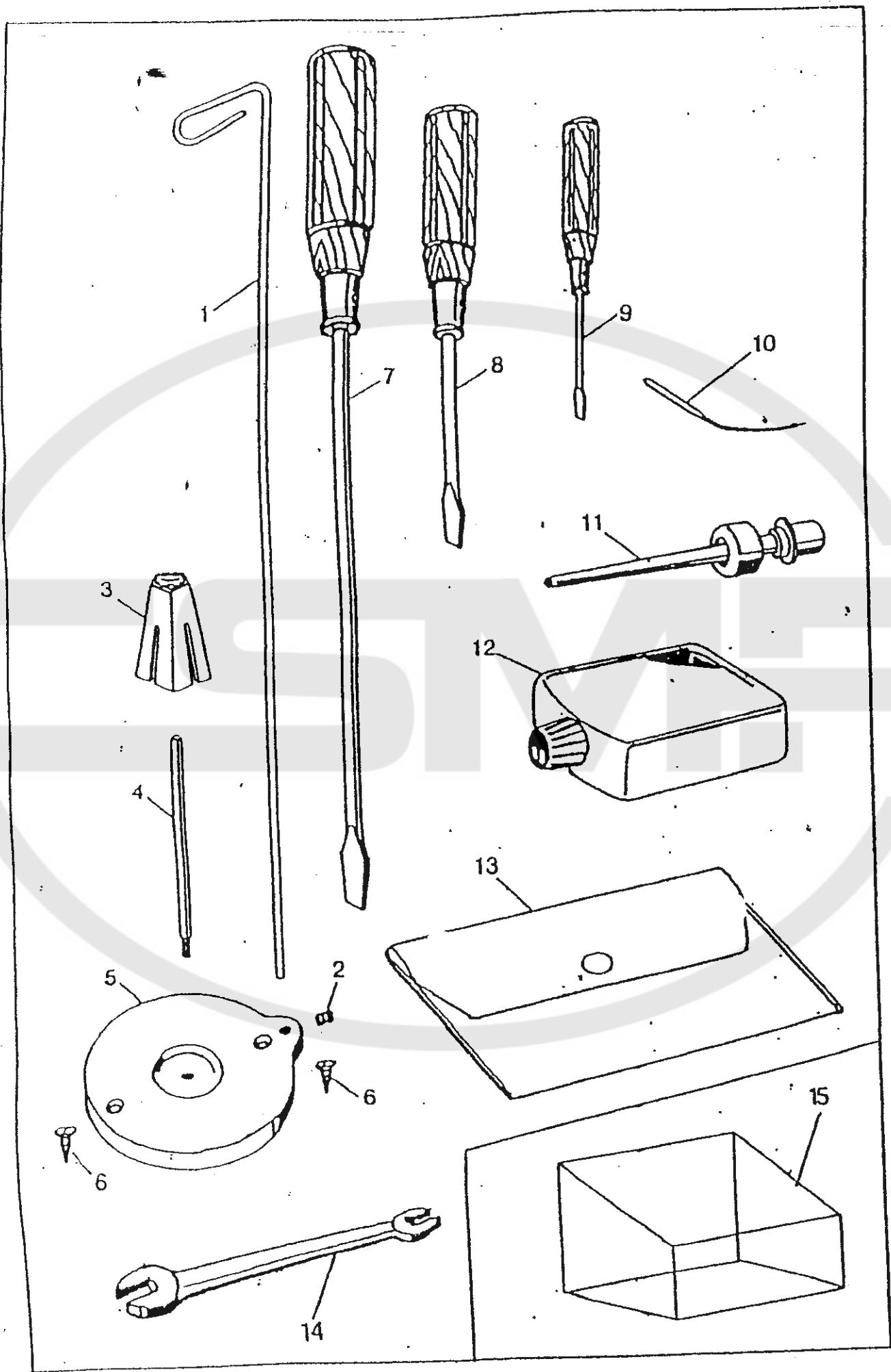

STANDARD ACCESSORIES

REF NO.	Parts No.	Description
1	4152	Thread Guide
2	129-A	Screw
3	AC-101	Plastic Cap
4	4151	Spool Pin
5	4150	Cotton Stand Base
6	AC-10A	Wood Screw
7	AC-01	Screw Driver (Large)
8	AC-02	Screw Driver (Medium)
9	AC-03	Screw Driver (Small)
10-1	21790-G1	Groz Needle #80
10-2	21790-G2	Groz Needle #70
11	AC-04-A	Oiler
12	AC-05-A	Oil
13	AC-08-A	Accessory Bag
14	AC-104	Spanner
15	C-30	Vinyl Cover