



# 超高速筒式绷缝机 ZJC2500

SUPER HIGH SPEED CYLINDER BED INTERLOCK SEWING MACHINE

## 使用说明书 零件手册 OPERATION MANUAL PARTS BOOK

中国·中捷缝纫机股份有限公司  
ZOJE SEWING MACHINE CO.,LTD.

## 前 言

### Preface

1、感谢您使用我公司生产的高速筒式绷缝机。

Congratulations and thank you for using high-speed cylinder bed interlock sewing machine manufactured by our company Sewing Machine Co.,Ltd.

2、在安装和使用之前，请仔细阅读本手册。若您不遵守本手册的说明而造成的人身伤害、机器损坏及其他财物损失我们将不承担责任。如有疑问，请与我们联系，我们将及时、热情地为您提供服务。

Please read this manual carefully before installing and using. If you do not abide by this manual that result in human hurt, machine damaged or some other losses, we will not be responsible for them. If you have any questions, please contact us, we will provide you in time and warm service.

3、本手册主要对高速绷缝机的结构特征、工作原理、安装与调试、使用与维护、故障分析与排除以及运输等方面作出说明。

This manual mainly describes the structure features, working principle, installation & debugging, usage & maintenance, failure analysis & solution, delivery etc.

4、本手册适用高速绷缝机。用户特殊定制的其他规格的同类产品可参照使用。

This manual is suitable for C2, some customize product can take this manual for reference.

5、本手册中出现的 product 外观图或其他图例或菜单屏幕等若与实际产品有所不同，使用时以实际产品为准。

pared the manual with actual products, if there are some differences in the attached images and other images like menu screen, it will be subject to the actual product during operation.

6、公司的产品技术会不断创新，产品手册也会随之更改。以后的所有更改，均不另行通知。

With constant technology innovation of our company, operation manual will change in correspondence. Data afterwards are subject to change without notice.

目录	INDEX	页/PAGE
1. 安装	INSTALL ATION	1
2. 马达与皮带	MOTOR AND BELT	1
3. 润滑	LUBRICATION	2
4. 润滑油更换	HOW TO CHANGE OIL	2
5. 滤油器更换	HOW TO CHANGE OIL FILTER	2
6. 机针与线的冷却与润滑	LUBRICATE AND THE COOLING OF NEEDLES AND THREADS	3
7. 机针更换	TO REPLACE NEEDLES	3
8. 穿线方法	THREADING	4
9. 压线松紧度调整	ADJUSTING THREAD TENSION	4
10. 针线张力调整	NEEDLE THREAD TENSION	4
11. 上饰线张力	TOP COVER THREAD TENSION	5
12. 压脚调整	ADJUSTING PRESSER FOOT	5
13. 针距调节	ADJUSTING STITCH LENGTH	5
14. 差动比调整	ADJUSTING DIFFERENTIAL FEED RATIO	6
15. 压脚压力强度调整	ADJUSTING THE PRESSURE OF PRESSER FOOT	6
16. 棉屑清除	CLEAN UP DUST	6
17. 穿线图	THREADING DIAGRAM	7
18. 台板图	TABLE CUT-OUT	8
19. 重要安全事项说明	IMPORT SAFETY INSTRUCTION	10
20. 规格件表	CONVERSION CHART	11
21. 零件手册	PARTS LIST	12

## 1、安装

## INSTALLATION

1. 依本机器附有台板裁制图及零件组合图所列之配件，依序安装防震机座、线架等。  
1. Before installing machine, please refer table cut-out drawing, and the necessary attachment as enclosed, according to the sequence of installation, to fix cushion base, thread stand.
2. 马达之转向为顺时针方向，皮带之松紧度以用于相向内压下2cm为宜，同时为了安全起见，请将皮带防护罩盖上，并旋紧螺钉。（图1&2）  
2. Be sure that the motor turning direction is clockwise, and the motor belt tension can be pressed with finger inward about 2cm. For safety reason, please fasten the belt cover.(Fig1&2)
3. 皮带轮与缝纫速度参照表1。  
3. Regarding machine speed and motor pulley diameter, please refer to Table 1.



图 Fig.1



图 Fig.2

S.P.M 转速	MOTOR PULLEY SIZE 皮带轮尺寸		BELT 皮带 尺寸
6000	105	125	36"
5500	95	115	↑
5000	85	105	35"
4500	80	90	↑
4000	70	85	34"

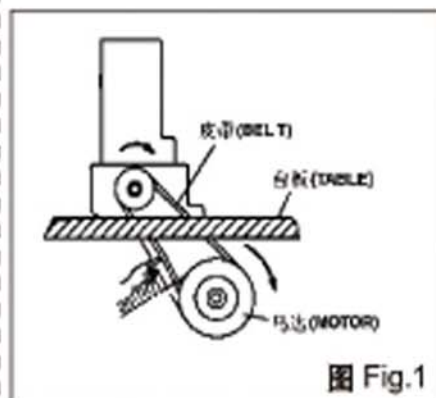
### 注意:

1. 使用新机器最初一个月运转速度约为最高转速的70%，并请选择正确的马达带轮尺寸（如表1）。
2. 台板厚度约50mm。

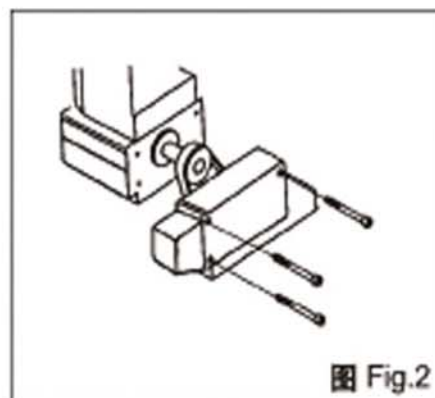
### Remarks:

1. During the first month of using the machine, the maximum speed shouldn't exceed 70% of the speed listed in Table 1. Make sure to choose the correct size of motor pulley.
2. The standard thickness of Table is about 50mm.

## 2、马达与皮带

## MOTOR AND BELT

1. 离合器马达 (550w) ,3相2极M番V型皮带。  
1. Clutch Motor (550W), 3 phase, 2 pole M type V belt.
2. 安装马达时，机器皮带轮与马达皮带轮的中线必须是一直线。  
2. The center line of both motor's and machine's pulley must be aligned each other, when installing the motor.

### 3、润滑

### LUBRICATION

1. 请选用M O B I L #1或E S S O #32或同级的润滑油。
2. 由于新机器在装运前已将油倒尽，因此新机器在使用前必须注入新油，转开上盖喷油窗(A)将油注入机器中，待油量满至油标指示上下线之间即可。(图3&4)
3. 每天必须检查，如果油已低于油标指示窗之下限，必须加注新油，当机器开始运转。操用前，必须检查整个润滑系统是否畅顺。

1. Please oil Mobit#10 or Esso#32 or its equivalent.
2. The lubricating oil has been drained from the machine before delivery, to remove screw(A), and fill the oil until the oil level reaches between lines H and L of oil level gauge. (Fig3&4)
3. Be sure to check every day and refill the oil, if oil level is lower than line L of oil level gauge.

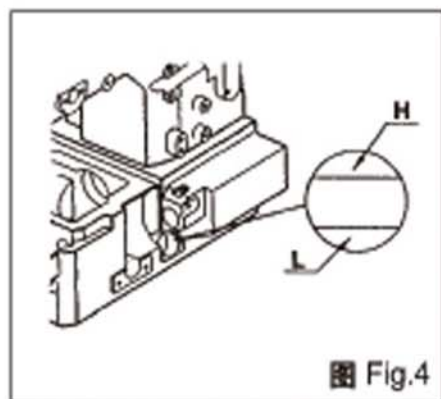
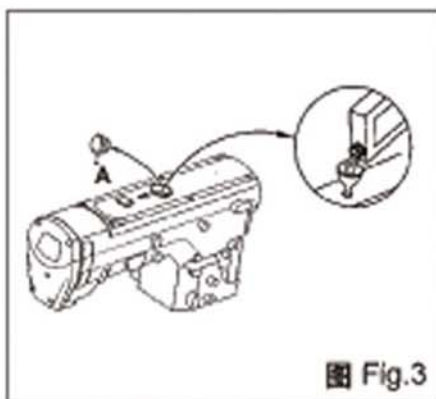

\* 新机器或久未使用的机器重新使用时，请先在针杆上下部加油润滑。

\* Before starting a brand-new machine or a machine which has not been used for more than a couple of week, oiling the needle bar.

### 4、润滑油更换

### HOW TO CHANGE OIL

1. 将螺丝(D)松开，使油槽之油完全排出后再锁紧。(图)
2. 为延长本机器寿命，请于开始使用的四个星期后更换新油，尔后约每四个月更换一次。

1. Loosen Screw(D), drain all the oil from the tank, then fasten the screw. (Fig 5)
2. For extending the life of the machine, change oil after the initial 4-week operation. After that, change oil every four months.

### 5、滤油器更换

### HOW TO CHANGE OIL FILTER

本机器特别装有滤油器，约每使用一个月后应卸下清洗，必要时得换新品。(图6)

This machine is equipped with an oil filter, and the filter must be cleaned every month, replace the filter if necessary. (Fig 6)

## 6、机针与线冷却润滑

## LUBRICATE AND THE COOLING OF NEEDLES AND THREADS

在油槽①②内注入硅油以防止断线。(图7)

Fill reservoir ① and ② with silicone oil to prevent the thread from breaking. (Fig 7)

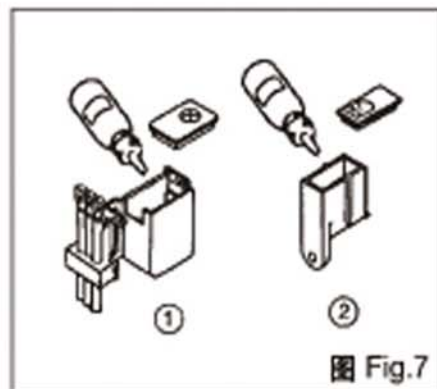
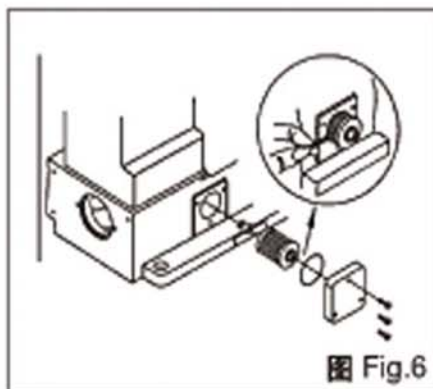
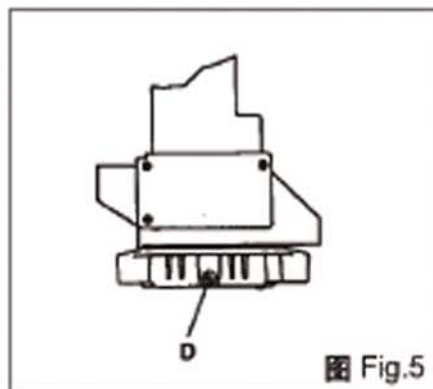

## 7、机针更换

## HOW TO REPLACE THE NEEDLES

1. 选用机针的规格与尺寸请参照(表2)。
2. 旋转螺丝并取下针，将新针插至针座最底端，并使针的长沟面向自己。(图8)
3. 重新锁紧螺丝。

1. See Table 2 of the sizes and the specifications of the needles.
2. Loosen Screw, then pull out the used needles, inset the new needles into the holder holes as far as they can go, and let the long groove of the needle face you. (Fig 8)
3. Fasten Screw.

Table (表2)		
Needle System 针代号	Needle Size/针尺寸	
	2 Needles	3 Needles
SCHMETTZ UY128GAS	#70	#75
ORGAN 128GAS	#10	#11

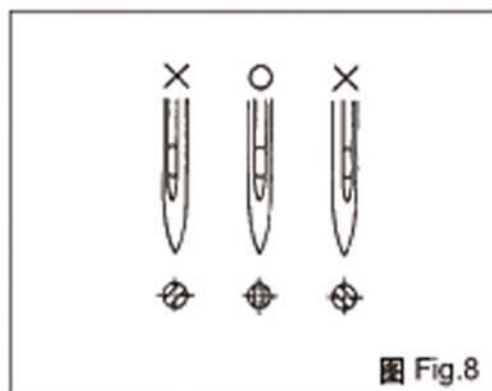

\* 特殊机种针的代号请参考规格表。

\* Needle size of special model, please refer to conversion Chart.

## 8、穿线方法

应按照不同缝合情况穿线，错误的穿线方法将引起断线、跳线针或缝样不平等现象。必须参照第七页穿线图。

## THREADING

Follow the procedures shown in(Fig 9)for threading. Wrong threading may cause thread breaking,skipping stitch, puckering or unexpected sewing. Please refer to Page 7.

## 9、压线松紧度调整

线的拉力强度必须根据缝料的材质厚薄。线与针距不同而调整，将调节旋钮顺时针方向旋转，线压得越紧；向逆时针方向旋转，线压力越轻。(图 9)

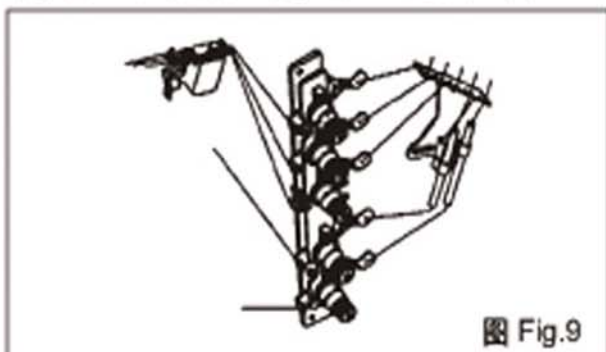

## ADJUSTING THREAD TENSION

The tension of the thread should be adjusted according to:

1. The material and the thickness of the fabric being sewed;
2. The thread;
3. The needle gauge.

If you turn the thread tension knob clockwise, thread will be tighter. (Fig 9)

If you turn it counterclockwise, will be looser.

## 10、针线张力调整

当针杆处于上限位置时，针线挑线杆A的a边处于水平状态，其顶部距螺钉B中心为52mm，这是标准的。紧线时，先松螺钉B，将针线挑线杆向Y向移动，相反，松线时向X向移动。如果通过以上调整针线张力还未能调好，可以松掉螺钉C移动油箱固定板来调整，向Y同移动时线收紧，向X向移动时线放松，在标准状态下，穿线孔上边缘到螺钉C中心距离为8mm。(图10&11)

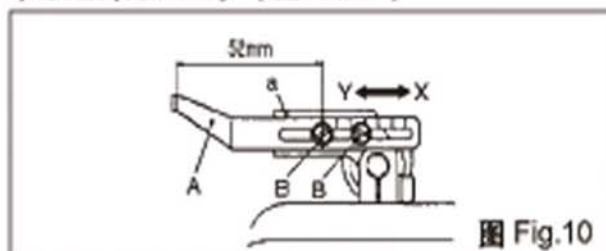

## Needle thread tension

The part(a) of Needle Thread take-up(A)is horizontal when its tip is 52mm from the center of Screw(B) and Needle Bar is at its highest position. That is the standard. To tighten needle thread, move Needle Thread Take-up(A) in the direction of (Y),and to release, move it in the direction of (X). This adjustment is made by loosening Screw (B) (Fig.10)

When this adjustment is not sufficient,check thread tension by moving Thread Eyelet (D)after loosening Screw (C). When it is moved in the direction of (Y),the thread is tightened and in the direction(X),the thread is loosened. The upper end of Eyelet is 8mm above the center of Serew(C). That is the standard adjustment. (Fig.11)

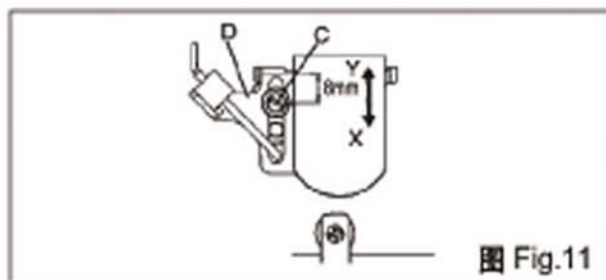

## 11、上饰线张力

## TOP COVER THREAD TENSION

沿X向提升右绷线过线板A，线松弛，沿Y向降下右绷线过线板A，线收紧，当绷线为弹性线（如毛质线）时，线要松弛，松开螺钉B，降低右绷线过线板，并将毛质线从右绷线过线板的下孔穿过。

(图12)

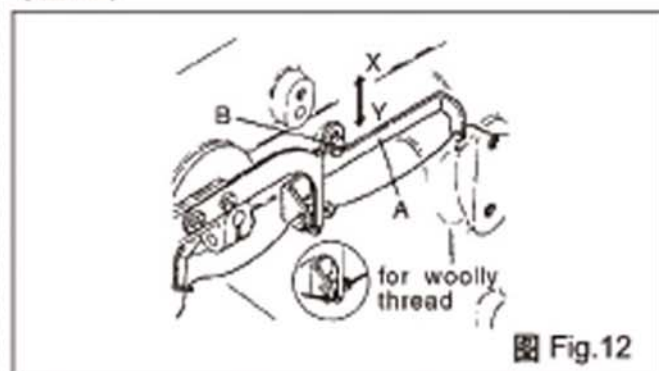

When raising Top Cover Thread Eyelet (Right)(A) to the direction(X),the thread take-up decreases,and descending it downward the thread take-up increases. When using stretchable thread such as woolly thread for top cover thread, descend Top Cover Thread Eyelet(Right)(A) to the direction (Y) by loosening Screw (B).In case of using woolly thread, pass it through the lower eye. (Fig.12)

## 12、压脚调整

## ADJUSTING PRESSER FOOT

松开螺钉①，左右摇动以调整压脚②，使针尖端刚好位于如示之中心点。调整后，再锁紧螺钉①。

(图13)

Loosen Screw ①and adjust Presser Foot ②left and Right to a proper position to let the needle may get into the centre of Presser Foot's eyelet. After adjusting, tighten screw ①. (Fig.13)

## 13、针距调节

## ADJUSTING STITCH LENGTH

针距调节范围为1.4—4.4mm，采用摇杆式针距调节机构，可轻松方便的调整针距。(图14)

松开螺母①，上下移动针距调节杆②，调整针距。

Stitch length can be adjusted from 1.4-4.4mm, The micro stitch length regulating lever which could adjust the stitch length easily. (Fig.14)

To adjust the stitch length, loosen the nut ①, move the indicator ②up or down.

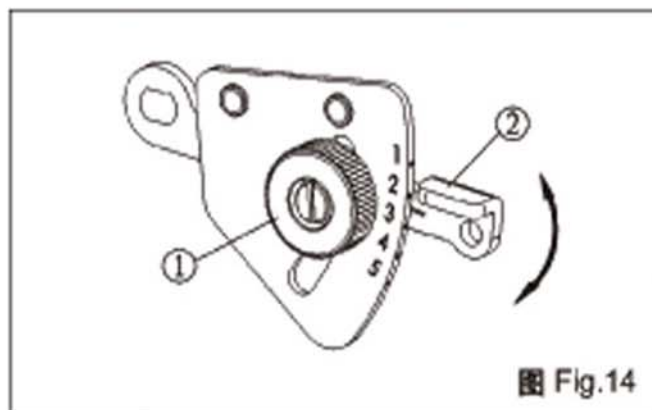
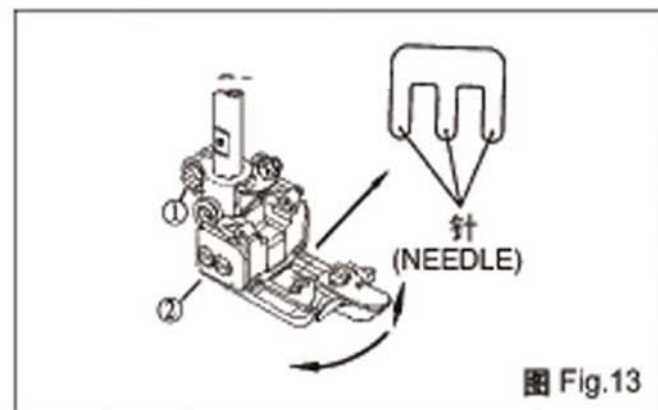



#### 14、差动比调整

#### ADJUSTING DIFFERENTIAL FEED RATIO

本机器之差动比可从1:0.7调整至1:1.6, 松开螺钉②, 上下移动调节滑块①调整差动。(图15)

The differential feed Ratio of this machine is adjustable from 1:0.7 to 1:1.6. (Fig.15) To adjust the ratio, loosen the screw ②, move the adjusting slick block ① up or down.

\* 要伸张布料车缝即差动变小时, 则将调节滑块往下移。

\* To stretch the cloth, or minish the feed ratio, move the Adjusting Slide Block ① downward.

\* 需要褶皱车缝即差动调大时, 则将调节滑块往上移。

\* To gather the cloth, or in crease the feed ratio, move the Adjusting Slide Block ① upward.



图 Fig.15

#### 15、压脚压力强度调整

#### ADJUSTING THE PRESSURE OF PRESSER FOOT

在布料推送顺畅且缝合完美之情况下, 压脚压力尽量轻些。(图16)

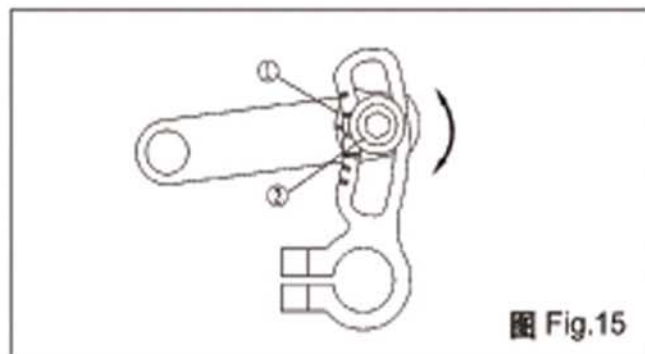
Pressure of the Presser Foot should be as light as possible, so that cloth can be feed and sewed smoothly.(Fig.16)

#### 16、棉屑清除

#### CLEAN UP DUST

请定期打开MQ22, 清除棉屑, 以维护机器寿命。(图17)。

Please unplug the stopper MQ22, clean up dust and waste every month.(Fig.17)



图 Fig.16



图 Fig.17

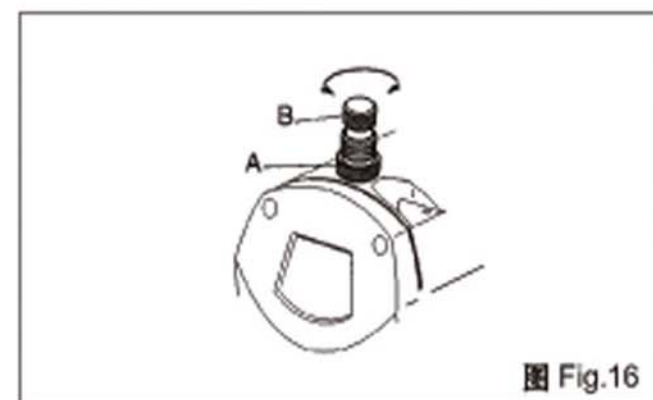

## 18、台板图(1)

## TABLE CUT-OUT (1)

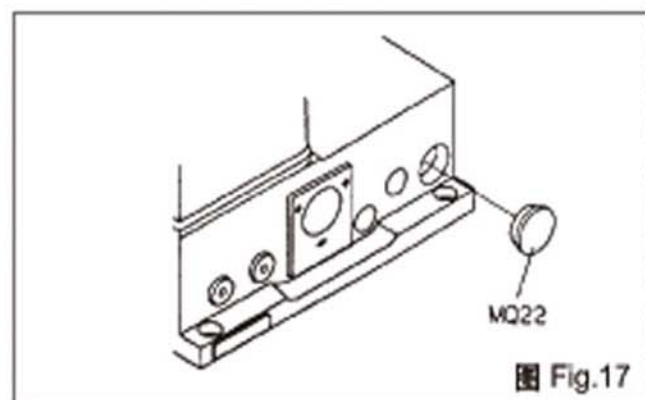
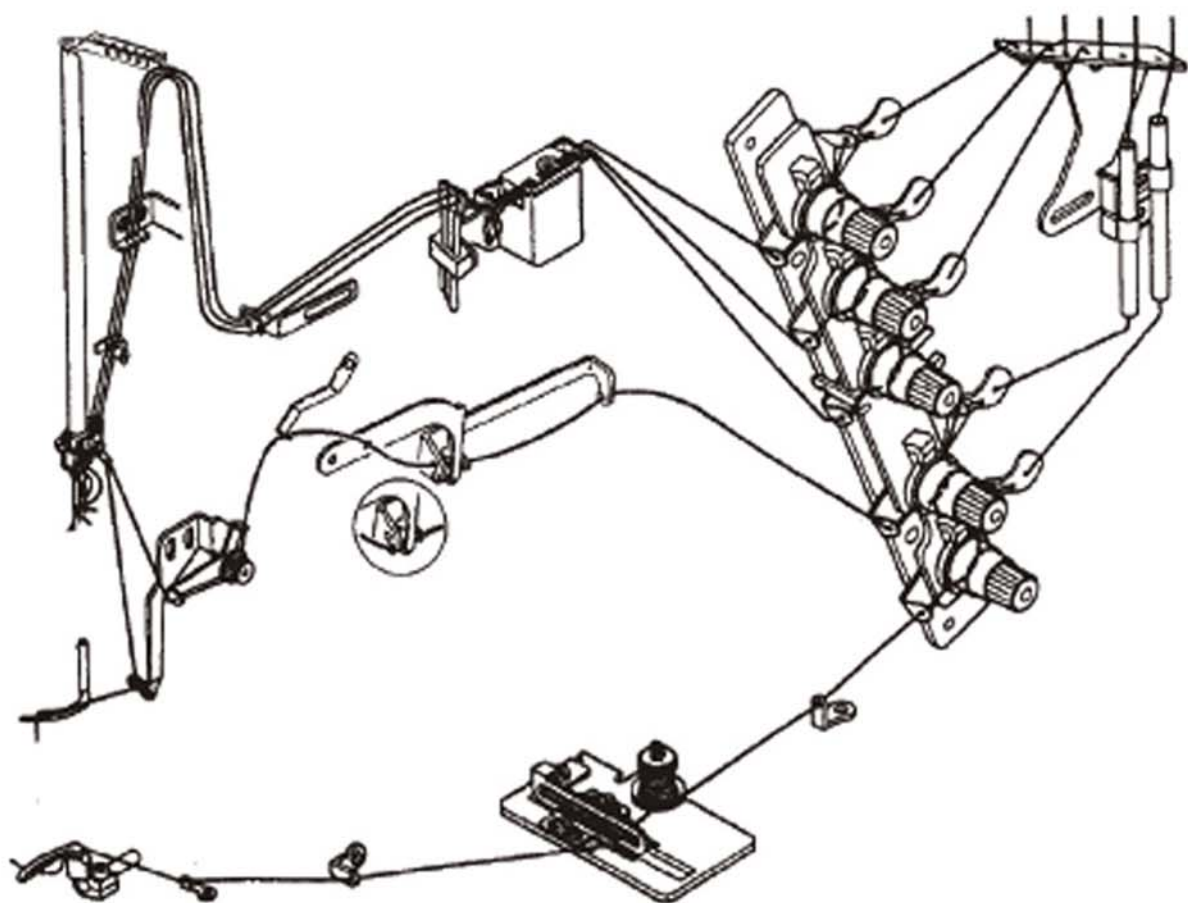
FOR: C 2500、C 2400

单位/UNIT: MM

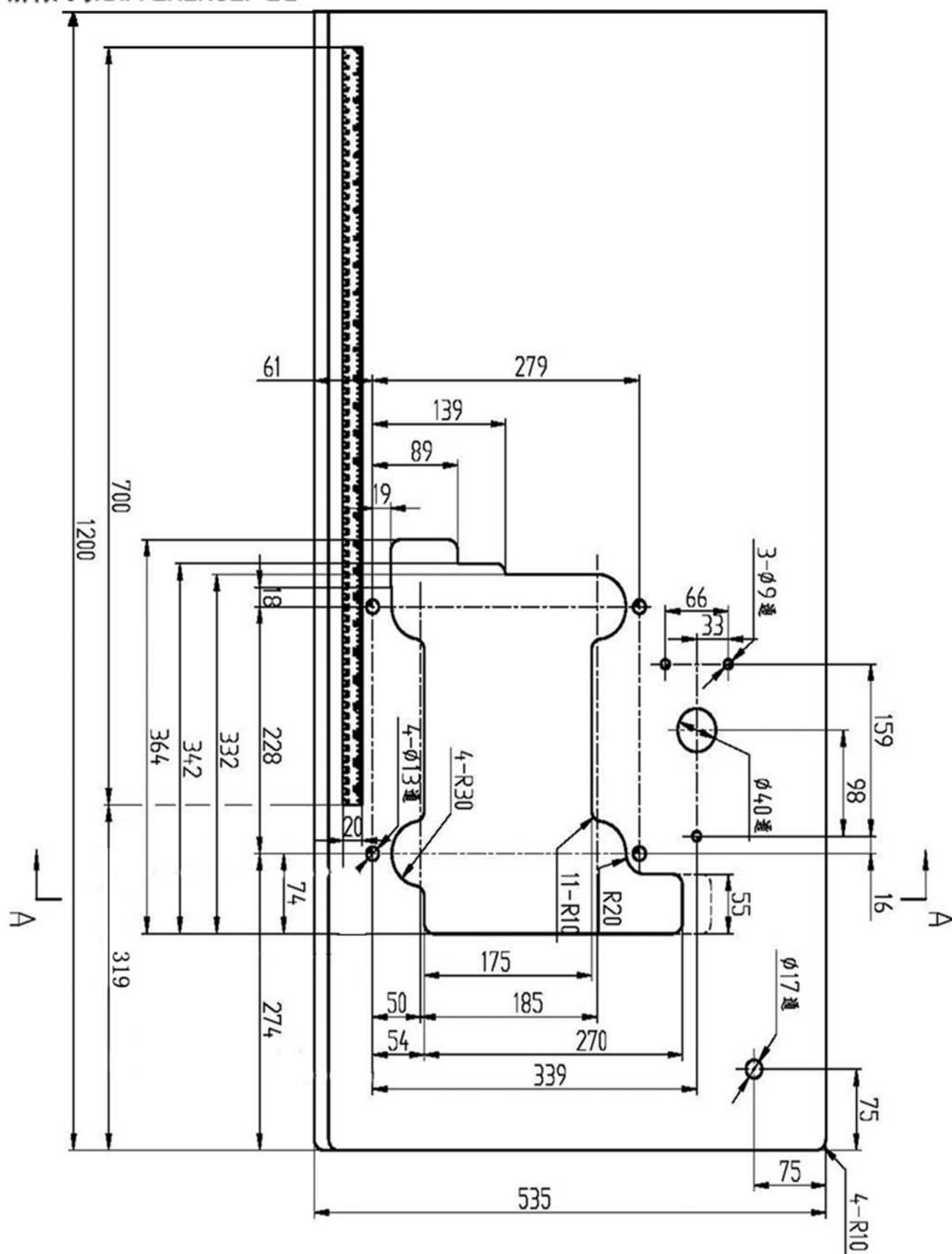
所有尺寸/DIFFERENCE:  $\pm 2$ 

## 18、台板图(2)

## TABLE CUT-OUT (2)

FOR: C 2542

单位/UNIT: MM

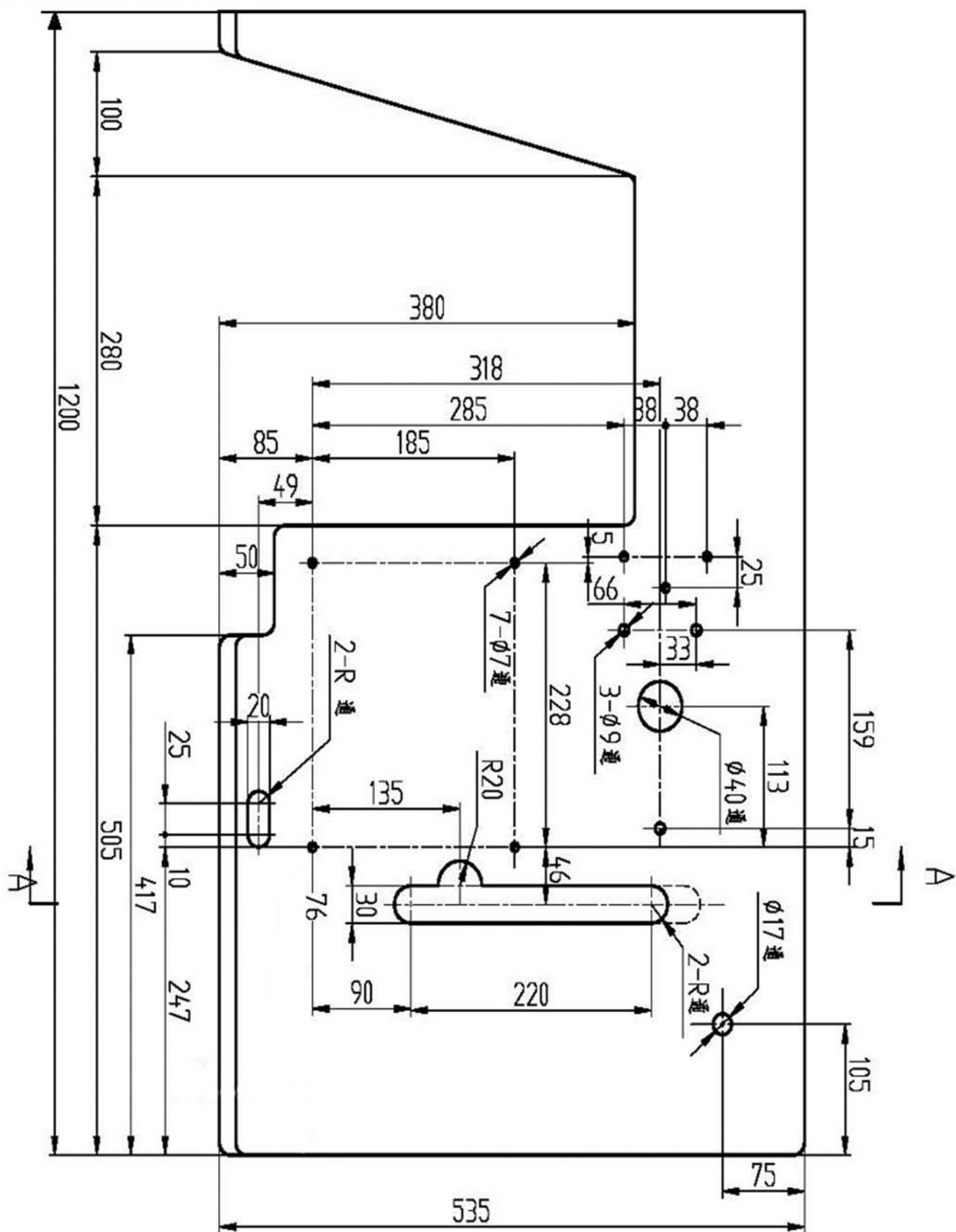
所有尺寸/DIFFERENCE:  $\pm 2$ 

## 1. 搬运作业

- (1). 使用机头袋将机器包装防护。
- (2). 放入纸箱内。
- (3). 用手推车或二人用双手抬动搬运。

## 2. 储存作业

- (1). 机器不使用时，应用防尘罩将其罩上。
- (2). 避免储存于高于45℃以上的高温。

## 3. 作业中

机器不要在高于40℃以上的温度工作。

## 4. 警告

在贴有警告标示之处请注意

1. 机械运动部份，请注意装上保护装置。
2. 穿线、换线、调整、清洁时请注意关闭电源。

## 1. Transportation

- (1). The machine packed with machine cover.
- (2). Put the machine into a carton.
- (3). Use a cart or by two men's hands to move it.

## 2. Storage

- (1). The machine must use duster-cover to cover it when it did not work.
- (2). The machine avoid to storage in the temperature more than 45℃.

## 3. Working











The machine doesn't work over 40℃.

## 4. Warning

1. Pay attention to this warning advice as follow.
  - a. Working area is dangerous.
  - b. Never touch the needle if the machine is still running.
  - c. Be careful if you infeed fabric.
  - d. Do not insert your finger between needle and roller for transportation on fabric.
2. Pay attention to the warning sticker.
  - a. Movable parts must be enclosed with guard when you operate.
  - b. Pull out the plug from socket when you adjust, thread, change bobbin and needle clean.

规格件表

CONVERSION CHART

									
MODEL 机型	SUB- CLASS 规格	NEEDLE CLAMP 针轧	NEEDLE PLATE 针板	MAINFEEED DOG 主送料牙	KIFF. FEED DOG 差动送料牙	PRESSER FOOT 压脚	SPREADER 绷针	LOOPER 弯针	NEEDLE 针号
C2400-140M	240	10011331	10010364	10012877	10014447	10004571			
C2400-148M	248	10011386	10012314	10012877	10014447	10010042			
C2500-156M	356	10011608	10012291	10012837	10012863	10014315			
C2500-164M	364	10011266	10010362	10012877	10014447	10014105			
C2403-140M	240	10011331	10010490	10014423	10014421	10006032			
C2403-148M	248	10011386	10010400	10014423	10014421	10014192			
C2503-156M	356	10011608	10010489	10014423	10014421	10014304			
C2503-164M	364	10011266	10010401	10012876	10012874	10014193			
C2413-148M	248	10011386	10012314	10012877	10014447	10005578			
C2513-156M	356	10011608	10012291	10012837	10012863	10005599			
C2513-164M	364	10011266	10010362	10012877	10014447	10014427	10011662	10012780	UY128GAS 11#
C2542PR-156M	356	10011608	10010489	10014423	10014421	10012556			
C2542PR-164M	364	10011266	10010401	10012876	10012874	10010363			
C2421-148M	248	10011386	10004187	10012247	10009690	10004190			
C2521-156M	356	10011608	10012256	10012247	10009690	10009756			
C2521-164M	364	10011266	10010615	10012247	10009690	10004192			
C2500P-156M	356	10011608	10012291	10012837	10012863	10014315			
C2500P-164M	364	10011266	10010362	10012877	10014447	10014105			
C2400-148M/S	248	10011386	10010400	10014423	10014421	10014192			
C2500-156M/S	356	10011608	10010489	10014423	10014421	10014304			
C2500-164M/S	364	10011266	10010401	10012876	10012874	10014193			

目录	CONTENTS	页/PAGE
1 机壳部件(1)	MISCELLANEOUS COVERS (1)	13
2 机壳部件(2)	MISCELLANEOUS COVERS (2)	15
3 过线部件	MISCELLANEOUS THREAD EYELETS	17
4 上轴及挑线部件	UPPER SHAFT & NEEDLE THREAD TADKE-UP MECHANISM	19
5 抬压脚部件	PRESSER FOOT MECHANISM	21
6 针杆部件	NEEDLE BAR MECHANISM	23
7 主轴部件	MAIN SHAFT DRIVING MECHANISM	25
8 弯针部件	LOOPER DRIVING MECHANISM	27
9 差动送布部件	FEED DRIVING MECHANISM	29
10 差动调节部件	FEED DRIVING CONTROL MECHANISM	31
11 绷针部件	SPREADER MECHANISM	33
12 润滑部件	LUBRICATING MECHANISM	35
13 滚领绷缝机专用件	SUBMODEL EXCLUSIVE PARTS	37
14 倒骨缝绷缝机专用件	SEAMS COVRING SEWING MACHINE EXCLUSIVE PARTS	39
15 氨轮专用零部件(1)	Urethane Stitch EXCLUSIVE PARTS (1)	41
16 氨轮专用零部件(2)	Urethane Stitch EXCLUSIVE PARTS (2)	43
17 直驱机型专用件	DIRECTLY DRIVING TYPE EXCLUSINE PARTS	45
18 拖布轮专用件(1)	UPPER FEED ROLLER EXCLUSIVE PAETS (1)	47
19 拖布轮专用件(2)	UPPER FEED ROLLER EXCLUSIVE PAETS (2)	49
20 左切刀专用件(1)	LEFT-COUNTER EXGLUSIVE PART (1)	51
21 左切刀专用件(2)	LEFT-COUNTER EXGLUSIVE PART (2)	53
22 左切刀专用件(3)	LEFT-COUNTER EXGLUSIVE PART (3)	55
23 附件盒	ATTACHMENT BOX	57
24 线架	THEAD STAND	59
25 包装箱	BOX	61

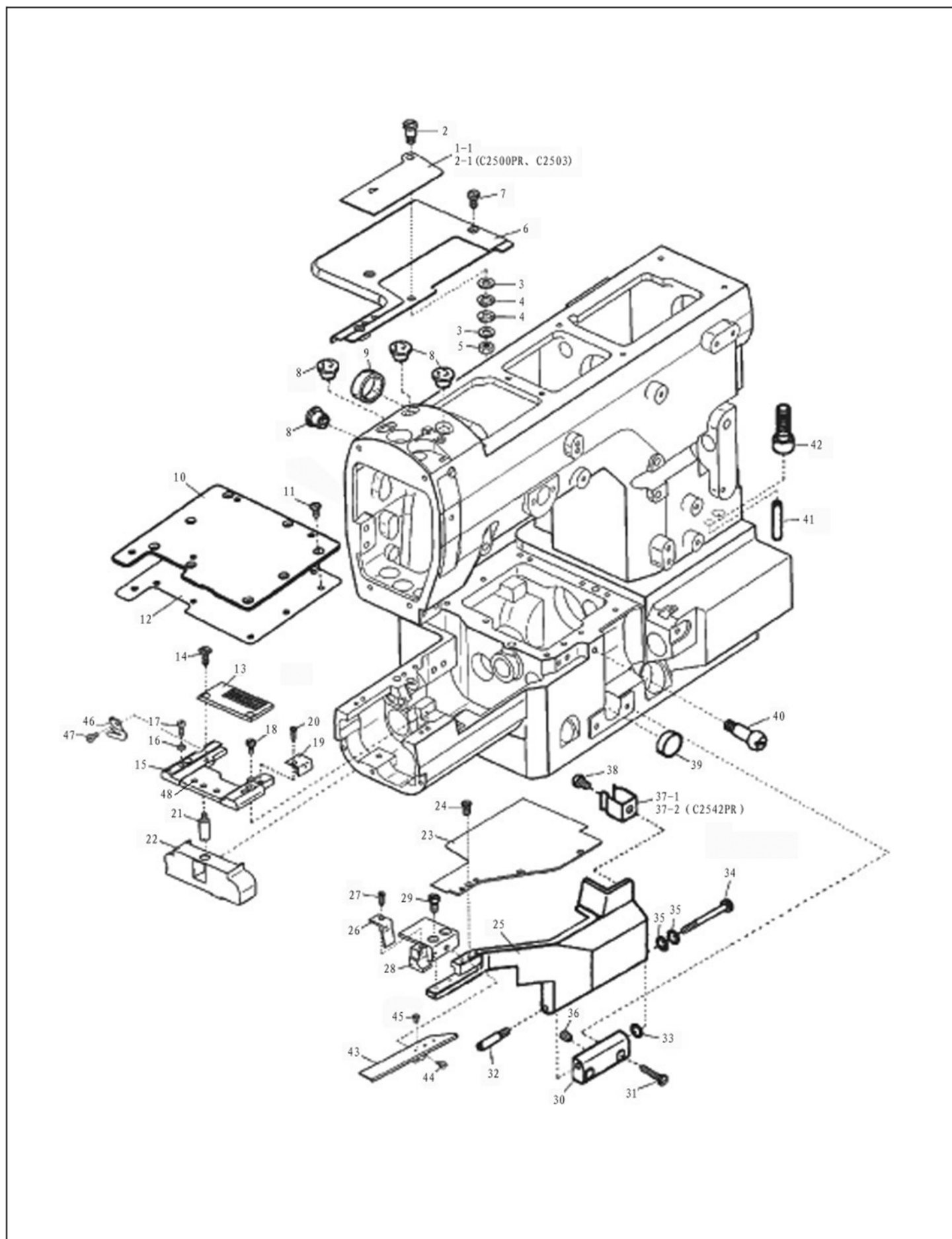



## 机壳部件(1)

## MISCELLANEOUS COVERS(1)

序号 No.	件号 Pars No.	名称	Description	数量 Number
1-1	10012292	上罩板摇板	Looper Thread Take-up Cover	1
1-2	10010500	上罩板摇板	Looper Thread Take-up Cover	1
2	10011222	螺钉(M4)	Screw(M4)	1
3	10002995	垫圈	Washer	2
4	10009470	垫圈	Washer	2
5	10009471	螺母	Nut	1
6	20003641	上罩板焊合件	Cloth Plate	1
7	10013178	螺钉(M4×12)	Screw(M4×12)	3
8	10013170	橡胶塞	Seal Pulg	4
9	10011186	油封	Oil Seal	1
10	10012588	弯针传动盖	Crant Chamber Cover	1
11	10012641	螺钉(M4×6.4)	Screw(M4×6.4)	8
12	10012595	弯针传动盖防油垫	Crant Chamber Cover Gasket	1
13	*	针板	Stitch Plate	1
14	10012688	螺钉(M3.5×4.5)	Screw(M3.5×4.5)	2
15	10012309	针板接板	Stitch Plate Support	1
16	10013872	针板架定位销	Knock Pin	2
17	10012253	螺钉(M3×8)	Screw(M3×8)	2
18	10013938	螺钉(M4×10)	Screw(M4×10)	2
19	10012293	针板接板罩组件	Stitch Plate Support Cover	1
20	10012730	螺钉(M3×5.6)	Screw(M3×5.6)	1
21	10012295	螺钉(M5)	Screw(M5)	1
22	10012248	挡油板	Oil Proof Cover	1
23	20003622	穿线罩板盖	Front Cover (Upper)	1
24	10012642	螺钉(M3.5×7)	Screw(M3.5×7)	3
25	20003621	穿线罩板	Front Cover	1
26	10012240	穿线罩板前板罩组件	Front Plate	1
27	10012730	螺钉(M3×5.6)	Screw(M3×5.6)	1
28	20003619	穿线罩板前板	Front Plate Support	1
29	10002959	螺钉(M4×16)	Screw(M4×16)	2
30	20003623	穿线罩板铰链	Front Cover Hinge	1
31	10012594	螺钉(M4×18.5)	Screw(M4×18.5)	2
32	10012598	螺钉(M4×8)	Screw(M4×8)	1
33	10003073	垫圈	Washer	1
34	10012592	螺钉(M4×30)	Screw(M4×30)	1
35	10003026	垫圈	Washer	2
36	10009074	螺钉(M4×4)	Screw(M4×4)	1
37-1	10011220	弹簧	Spring	1
37-2	10012699	弹簧	Spring	1
38	10012728	螺钉(M3.5×4)	Screw(M3.5×4)	1
39	10012764	橡胶塞	Seal Pulg	1
40	10012721	螺钉(M4)	Screw(M4)	1
41	10007433	销	Pin	2
42	10007432	螺钉(M10)	Screw(M10)	4
43	10012250	穿线罩板接板	Front Cover Plate	1
44	10010594	螺钉(M4×7.5)	Screw(M4×7.5)	2
45	10012599	螺钉(M5×7.8)	Screw(M5×7.8)	2
46	10012311	割线刀	Cutter	1
47	10010888	螺钉(M3×6.6)	Screw(M3×6.6)	1
48	10012726	防震垫	Gasket	2

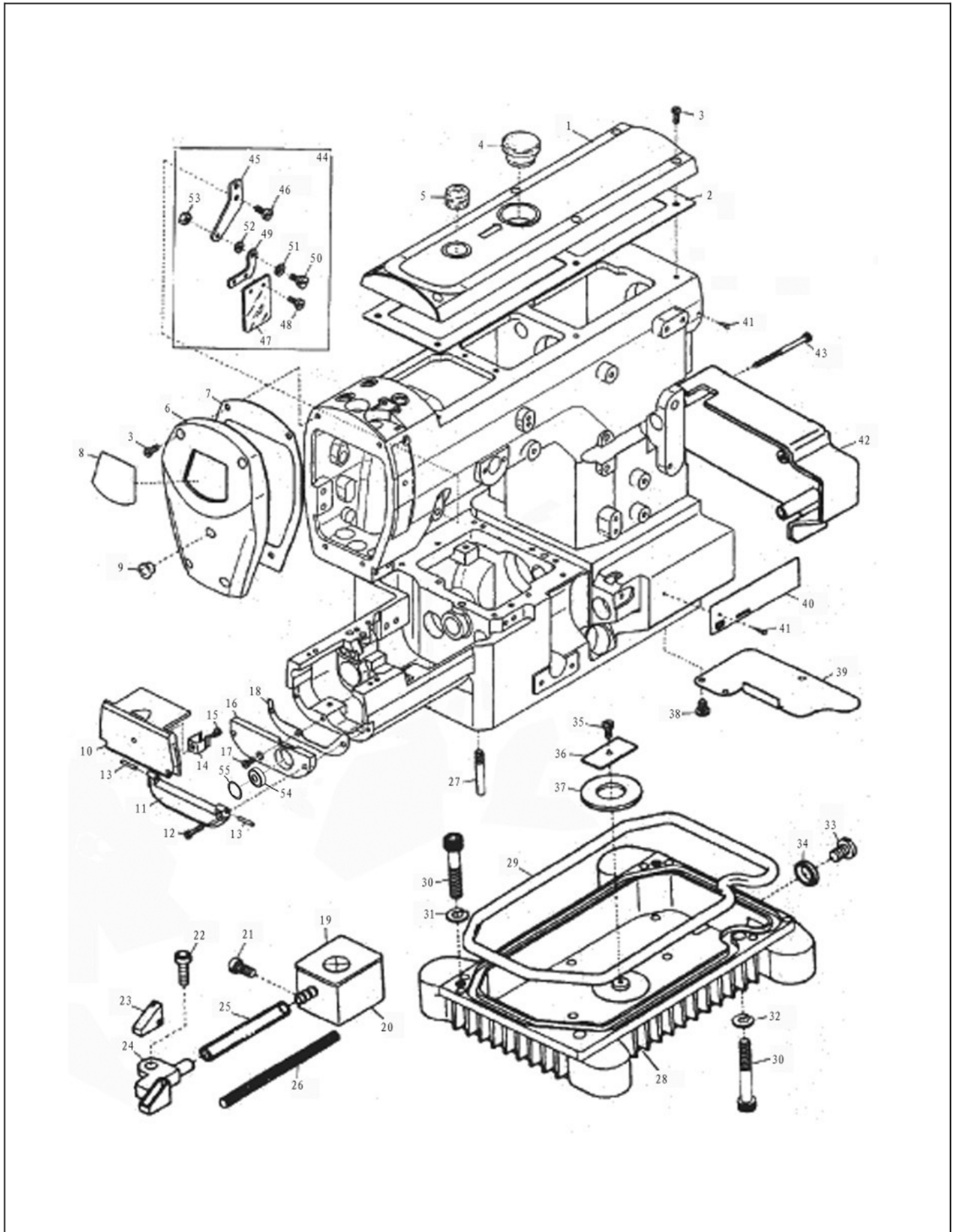

## 机壳部件(2)

## MISCELLANEOUS COVERS(2)

序号 No.	件号 Pars No.	名称	Description	数量 Number
1	20003608	上盖板	Top Cover	1
2	10012294	上盖板油垫	Top Cover Gasket	1
3	10010697	螺钉(M4×12)	Screw(M4×12)	10
4	10011006	橡胶塞	Seal Pulg	1
5	10012958	上盖油窗	Oil Sight Window	1
6	20006670	面板A	Head Cover	1
7	10010189	面板油垫	Head Cover Gasket	1
8	10005468	面板装饰牌	Emblem	1
9	10013170	橡胶塞	Seal Pulg	1
10	10012290	前罩板	Cylinder Side Cover(Upper)	1
11	10010184	前罩铰链座	Cylinder Side Cover Hinge	1
12	10010186	螺钉(M3.5×16)	Screw(M3.5×16)	2
13	10010185	螺钉(M2.5)	Screw(M2.5)	2
14	10011220	弹簧	Cover Latch Spring	1
15	10010188	螺钉(M3.5×3.6)	Screw(M3.5×3.6)	1
16	10010187	下轴前轴承安装板	Cylinder Side Cover(Lower)	1
17	10010157	螺钉(M3.5×9)	Screw(M3.5×9)	1
18	10012720	前罩铰链座垫	Gasket	1
19	10012542	硅油储盒	HP Container	1
20	10012551	硅油储盒盖	HP Container Cover	1
21	10012509	螺钉(M3.5×8)	Screw(M3.5×8)	2
22	10012553	螺钉(M4×8)	Screw(M4×8)	1
23	10012552	毛毡	HP Felt	1
24	10012547	硅油盒壳体	HP Cup	1
25	10007796	油管φ4×φ6×45	Oil Tube	1
26	10008075	油线φ2×80	Felt	1
27	10012684	底板支柱	Machine Frame Supporting Bar	4
28	10012545	油盘	Oil Reservoir	1
29	10012541	油盘垫	Oil Reservoir Gasket	1
30	10003142	螺钉(M8×25)	Screw(M8×25)	4
31	10006282	垫圈	Washer	2
32	10003331	垫圈	Spring Washer	2
33	10009264	螺钉(SM3/8"×28)	Screw(SM3/8"×28)	1
34	10009263	垫圈组件	Washer	1
35	10002963	螺钉(M4×10)	Screw(M4×10)	1
36	10012110	压板	Magnet Holder	1
37	10004427	油盘磁铁	Magnet	1
38	10012723	螺钉(M4×5)	Screw(M4×5)	3
39	10012683	底罩板	Dust Proot Plate	1
40	*	型号牌	Modle Plate(See The Below)	1
41	10002840	铆钉	Rivet	3
42	10012310	皮带罩	Belt Cover	1
43	10012685	螺钉(M4×47)	Screw(M4×47)	3
44	20002142	安全板组件	Eye Guard, Complete Set	1
45	10011179	安全架座	Safety Plate Support	1
46	10011618	螺钉(M6×9)	Screw(M6×9)	1
47	10011164	安全板	Safety Plate	1
48	10011176	螺钉(SM3/32"×56)	Screw(SM3/32"×56)	2
49	10011167	安全板架	Safety Plate Holder	1
50	10011178	螺钉(SM11/64"×40)	Screw(SM11/64"×40)	1
51	10011261	垫圈	Spring Washer	1
52	10011168	垫圈	Washer	1
53	10011170	螺母	Nut	1
54	10027118	轴承	Ball Bearing	1
55	10010041	下轴前轴承安装板盖	Bearing Cover	1

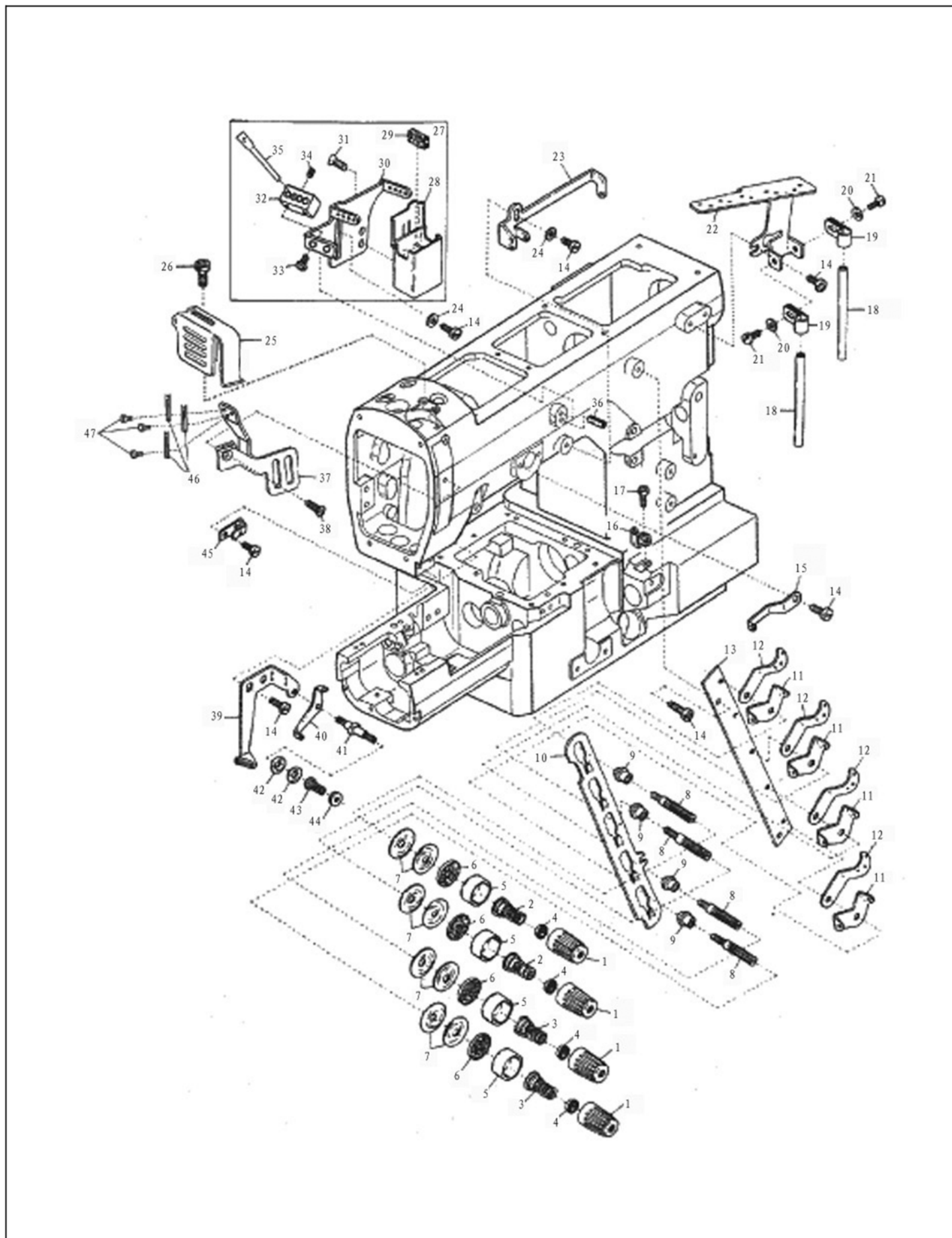

## 过线部件

## MISCELLANEOUS THREAD EYELETS

序号 No.	件号 Pars No.	名称	Description	数量 Number
1	10002538	夹线螺母	Thread Tension Spring Cap	5
2	10004233	弹簧	Spring	3
3	10004240	弹簧	Spring	2
4	10003111	防松垫	Tension Spring Disc Support	5
5	10004231	夹线簧座	Thread Tension Spring Retainer	5
6	10004238	夹线板垫	Felt	5
7	10003116	夹线盘	Tension Disc	10
8	10004232	螺钉	Screw	5
9	10004236	松线板套管	Tension Post Ferrule	5
10	10004234	松线板	Tension Disc Separater	1
11	10004239	双线过线板	Tension Disc Eyelet	5
12	10004241	单线过线板	Thread Lead-in Guide	5
13	10004235	夹线底板	Tension Post Support	1
14	10011264	螺钉 (M4×8)	Screw (M4×8)	10
15	10010486	左绷缝过线板	Top Cover Thread Eyelet (Left)	1
16	10012768	弯针过线座	Looper Thread Eyelet (Rear)	1
17	10010594	螺钉 (M4×7.5)	Screw (M4×7.5)	1
18	10010692	面线过线管	Thread Eyelet Pipe	2
19	10010693	面线过线管夹	Thread Eyelet Pipe Stay	2
20	10010696	垫圈	Washer	2
21	10009325	螺钉 (SM9/64"×40)	Screw (SM9/64"×40)	2
22	10010691	总过线板	Thread Guide Plate	1
23	10010754	绷缝调节过线板	Top Cover Thread Eyelet (Right)	1
24	10010761	垫圈	Washer	2
25	10013910	针杆护罩组件	Needle Thread Take-up Guard	1
26	10011264	螺钉 (M4×8)	Screw (M4×8)	2
27	20001572	硅油盒组件	SP Device, Complete Set	1
28	10010753	面线润滑油箱	SP Container	1
29	10010687	毛毡	Felt	1
30	10010522	油箱座	Needle Thread Eyelet	1
31	10010690	螺钉	Screw	2
32	10010497	硅油盒挑线座	Thread Eyelet Support	1
33	10002943	螺钉 (M3×5)	Screw (M3×5)	2
34	10013019	螺钉 (M3×4)	Screw (M3×4)	3
35	10010494	挑线钉	Thread Eyelet	3
36	10010750	销	Pin	1
37	10010499	面线中过线板	Needle Thread Eyelet	1
38	10011049	螺钉 (M4×8)	Screw (M4×8)	1
39	10004130	绷缝勒线板	Top Cover Thread Guide	1
40	10010747	绷缝调节过线板	Supplementary Thread Guide	1
41	10004254	螺钉	Screw	1
42	10004255	绷针夹线板	Supplementary Tension Disc	2
43	10005522	弹簧	Spring	1
44	10004253	螺母	Nut	1
45	10012229	面线下夹线座	Needle Thread Retainer Support	1
46	10010523	针杆松线钉	Needle Bow Diaplasia Plate	3
47	10014413	螺钉 (M2.5×4)	Screw (M2.5×4)	3

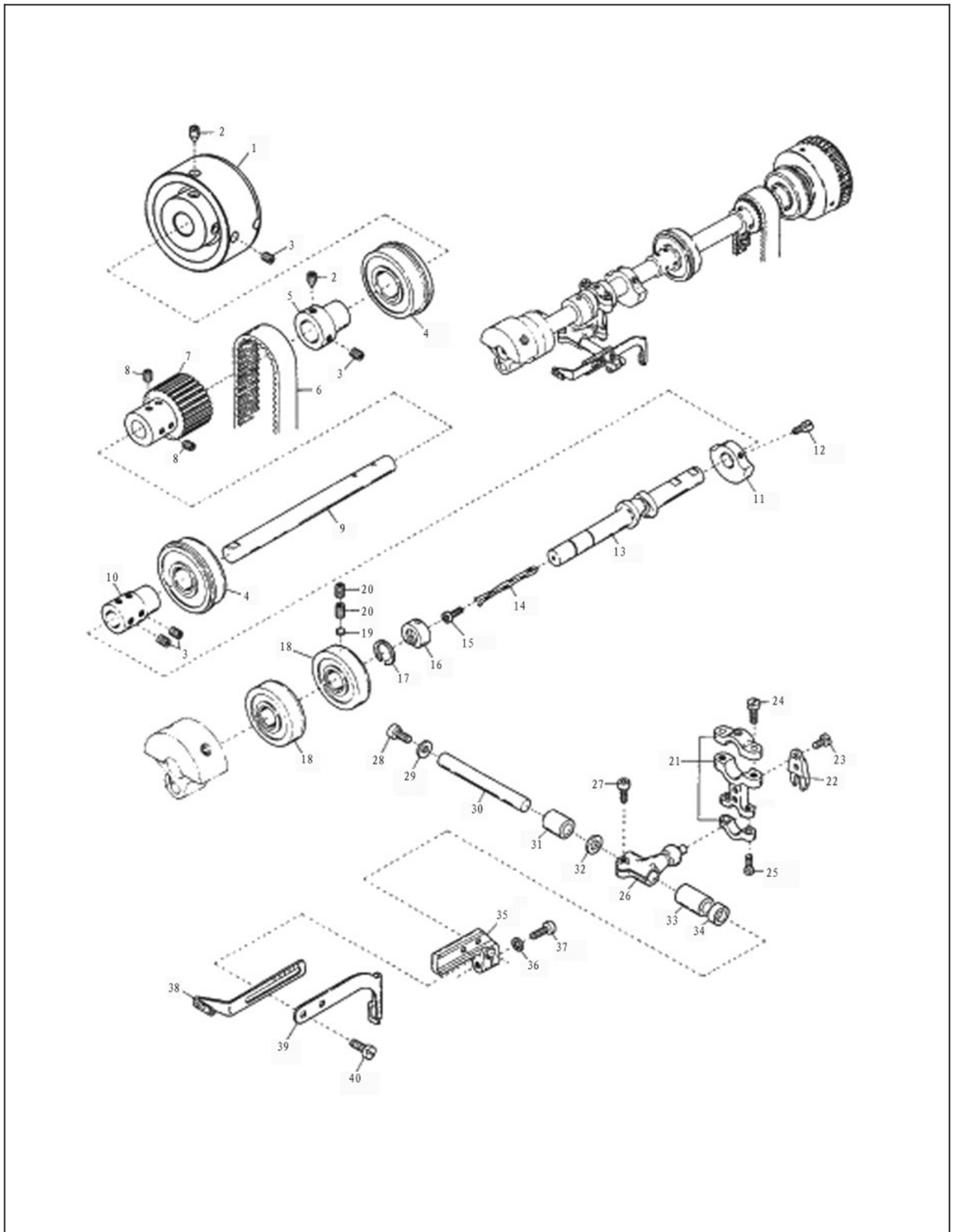

## 上轴及挑线部件

## UPPER SHAFT &amp; NEEDLE THREAD TAKE-UP MECHANISM

序号 No.	件号 Pars No.	名称	Description	数量 Number
1	20003609	手轮	Hand Wheel	1
2	10011966	螺钉 (M6×8)	Screw (M6×8)	2
3	10010907	螺钉 (M6×6)	Screw (M6×6)	6
4	10025881	轴承	Ball Bearing	2
5	10010950	挡圈	Hand Wheel Adapter	1
6	10008146	同步齿形带	Timing Belt (Upper)	1
7	10012801	从动时规轮	Upper Shaft Sprocher	1
8	10011969	螺钉 (M6×5)	Screw (M6×5)	4
9	10011163	上轴后节轴	Upper Shaft	1
10	10011172	上轴联接套	Upper Shaft Joint	1
11	10010955	上轴前接轴平衡块	Counterweight (Small)	1
12	10011264	螺钉 (M4×8)	Screw (M4×8)	2
13	10004407	上轴前节轴	Upper Crankshaft	1
14	10008063	油线 $\phi 1.5 \times 180$	Oil Wick	1
15	10011069	螺钉 (M4×4)	Screw (M4×4)	1
16	10011072	上轴前节进油套	Oil Sleeve	1
17	10003290	挡圈	Retaining Ring	1
18	10025896	轴承	Ball Bearing	2
19	10011174	轴承支头螺钉垫	Pulg	1
20	10011177	螺钉 (M6×5)	Screw (M6×5)	2
21	10004406	面线挑线连杆组件	Connecting Rod	1
22	10011052	球曲柄导向叉	Guide Fork	1
23	10011068	螺钉 (SM1/8"×44)	Screw (SM1/8"×44)	2
24	10014395	螺钉 (M4×14)	Screw (M4×14)	2
25	10011054	螺钉 (M3.5×10)	Screw (M3.5×10)	2
26	10004409	面线挑线球曲柄	Driving Lever	1
27	10009008	螺钉 (M6×16)	Screw (M6×16)	1
28	10010953	螺钉 (M5×10)	Screw (M5×10)	1
29	10010954	垫圈	Washer	1
30	10010959	球曲柄轴	Driving Shaft	1
31	10011112	轴套	Bushing	1
32	10011171	垫圈	Washer	1
33	10011115	轴套	Bushing	1
34	10011180	油封	Oil Seal	1
35	10010956	面线挑线插座	Bracket	1
36	10005537	垫圈	Washer	1
37	10010958	螺钉 (M5×14)	Screw (M5×14)	1
38	10010960	面线挑线杆	Needle Thread Take-up	1
39	10010957	绷线挑线杆	Top Cover Thread Take-up	1
40	10013159	螺钉 (M3.5×7.5)	Screw (M3.5×7.5)	2

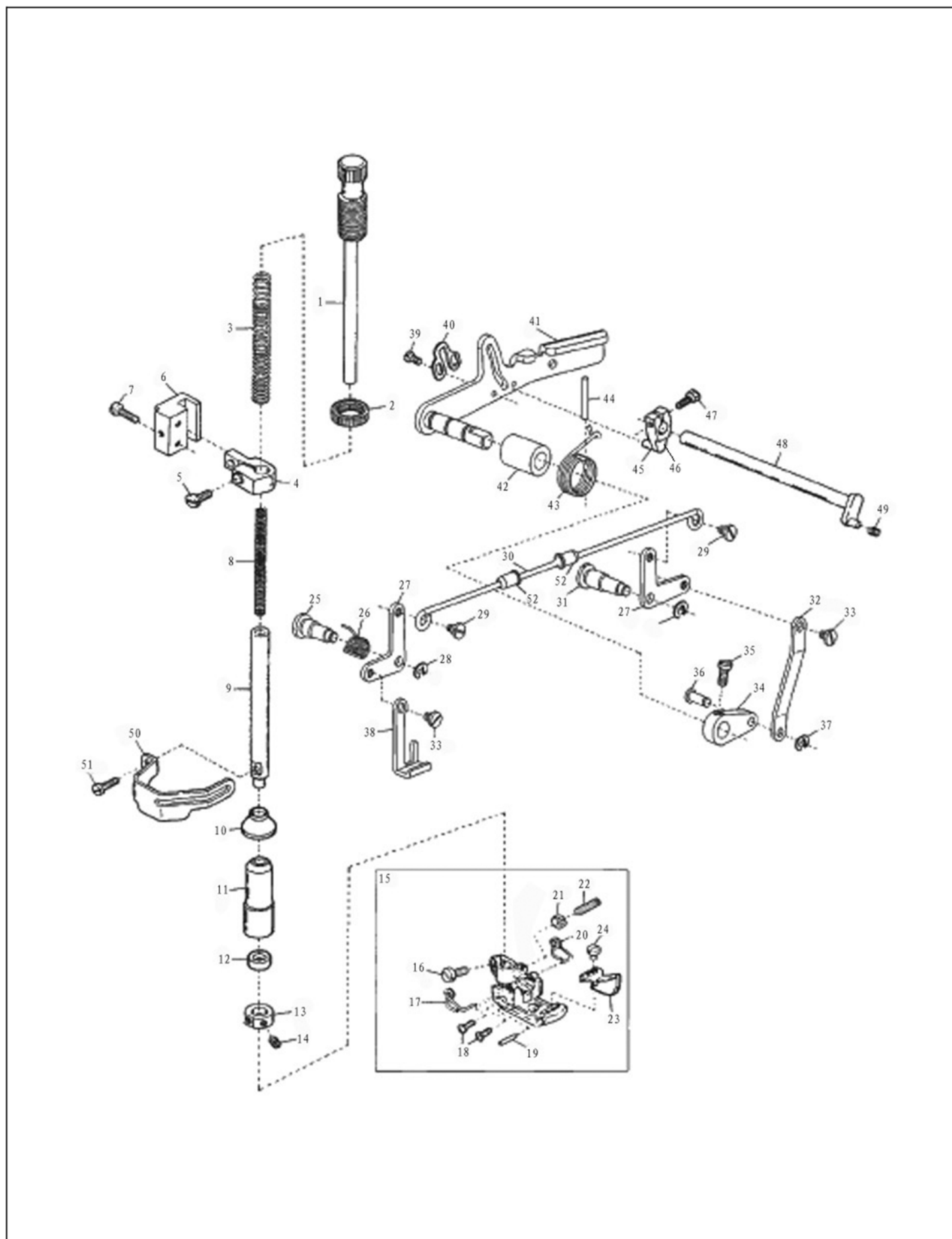



## 抬压脚部件

## PRESSER FOOT MECHANISM

序号 No.	件号 Pars No.	名称	Description	数量 Number
1	10004127	螺钉	Screw	1
2	10011913	螺母	Nut	1
3	10010492	调压簧	Spring	1
4	10011879	压杆导架部件	Presser Bar Connecting Bracket	1
5	10009037	螺钉 (M4×12)	Screw (M4×12)	1
6	10011883	压杆导轨	Presser Bar Guide	1
7	10013732	螺钉 (SM11/64"×40)	Screw (SM11/64"×40)	2
8	10011888	弹簧	Spring	1
9	10010496	压杆	Presser Bar	1
10	10011457	压紧杆防油罩	Oil Protector Cover	1
11	10011108	轴套	Bushing	1
12	10011180	油封	Oil Seal	1
13	10011878	挡圈	Collar	1
14	10011887	螺钉 (SM9/64"×40)	Screw (SM9/64"×40)	2
15	*	压脚组件	Presser Foot, Complete Set	1
16	10009115	螺钉 (M3.5×8)	Screw (M3.5×8)	1
17	10004710	弹簧	Spring	1
18	10003933	螺钉 (M2.5×4.2)	Screw (M2.5×4.2)	4
19	10005598	销	Pin	1
20	10004809	弹簧	Spring	1
21	10005577	螺母	Nut	1
22	10005576	螺钉	Screw	1
23	10005595	导向片体	Fabric Guide	1
24	10005573	螺钉 (M2.5×3.5)	Screw (M2.5×3.5)	1
25	10010521	杠杆螺纹销	Lever Pin	1
26	10010493	抬压脚复位扭簧2	Spring	2
27	10010463	抬压脚杠杆	Presser Foot Lever	2
28	10010649	挡圈	Collar	2
29	10013217	螺钉 (SM3/16"×40)	Screw (SM3/16"×40)	2
30	10010464	抬压脚拉杆	Presser Foot Rod	1
31	10010524	后杠杆螺纹销	Lever Pin	1
32	10010468	抬压脚连接板	Connecting Plate	1
33	10003496	轴位螺钉	Screw	2
34	10010458	抬压脚曲柄	Lifter Lever	1
35	10011664	螺钉 (SM15/64"×28)	Screw (SM15/64"×28)	1
36	10011886	销	Pin	1
37	10003248	挡圈	Collar	1
38	10010487	抬压脚升降板	Lifter Link Plate	1
39	10010904	螺钉 (SM9/64"×40)	Screw (SM9/64"×40)	2
40	10011889	抬压脚限位板	Lifter Lever Stop	1
41	10010469	抬压脚凸轮板组件	Lifter Lever	1
42	10011105	轴套	Bushing	1
43	10010495	抬压脚复位扭簧1	Spring	1
44	10002772	销	Pin	1
45	10011628	销	Pin	1
46	10011617	抬压脚松线曲柄	Tension Release Lever	1
47	10011625	螺钉 (SM11/64"×40)	Screw (SM11/64"×40)	1
48	10014069	松线曲柄轴组件	Tension Release Shaft	1
49	10011880	弹簧	Spring	1
50	10011881	机针前护架	Finger Guard	1
51	10011882	螺钉 (M3×4.6)	Screw (M3×4.6)	1
52	10004599	扫线拉板橡胶罩	Seal Pulg	2

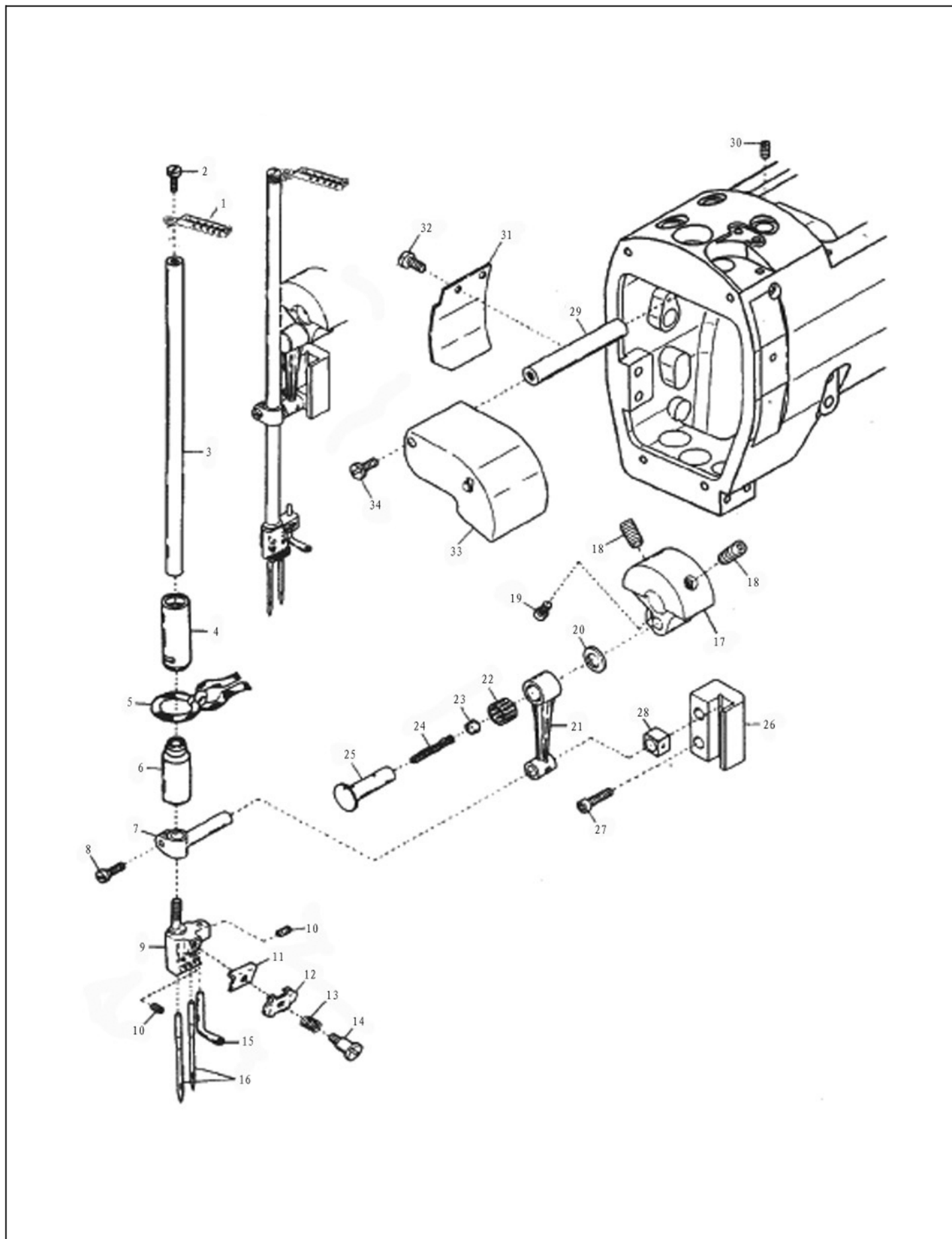

## 针杆部件

## NEEDLE BAR MECHANISM

序号 No.	件号 Pars No.	名称	Description	数量 Number
1	10013191	针杆挑线杆	Needle Bar Thread Eyelet	1
2	10010904	螺钉 (SM9/64"×40)	Screw (SM9/64"×40)	1
3	10010488	针杆	Needle Bar	1
4	10011103	轴套	Bushing	1
5	10008075	油线 $\phi 2 \times 80$	Oil Wick	1
6	10011104	轴套	Bushing	1
7	10011616	针杆连接柱	Needle Bar Bracket	1
8	10011044	螺钉 (M4×10)	Screw (M4×10)	1
9	*	针夹	Needle Clamp	1
10	10009255	螺钉 (SM1/8"×44)	Screw (SM1/8"×44)	4
11	10011349	针夹过线板	Thread Retainer Disc Support	1
12	10011345	针夹过线压板	Needle Thread Retainer Disc	1
13	10011338	弹簧	Spring	1
14	10011348	螺钉 (SM1/8"×44)	Screw (SM1/8"×44)	1
15	10011627	绷针过线勾	Top Cover Thread Eyelet	1
16	10004902	机针UY128GBS 11#	Needle	3
17	10013017	针杆曲柄	Counterweight	1
18	10011582	螺钉 (SM5/16"×24)	Screw (SM5/16"×24)	2
19	10010953	螺钉 (M5×10)	Screw (M5×10)	1
20	10011622	垫圈	Washer	1
21	10011629	针杆连杆	Connecting Rod	1
22	10007398	轴承	Roller Bearing	1
23	10011175	橡胶塞	Seal Plug	1
24	10008066	油线 $\phi 2.5 \times 48$	Oil Wick	1
25	10011169	销	Pin	1
26	10011619	针杆滑块导轨	Needle Bar Guide	1
27	10009103	螺钉 (M4×16)	Screw (M4×16)	2
28	10011340	针杆滑块	Slide Block	1
29	10011165	罩板销	Pin	1
30	10009074	螺钉 (M4×4)	Screw (M4×4)	1
31	10011173	针杆连杆后罩	Connecting Rod Cover (Rear)	1
32	10013040	螺钉 (M3×6)	Screw (M3×6)	2
33	10011581	针杆连接前罩	Connecting Rod Cover (Front)	1
34	10010837	螺钉 (M4×5)	Screw (M4×5)	1

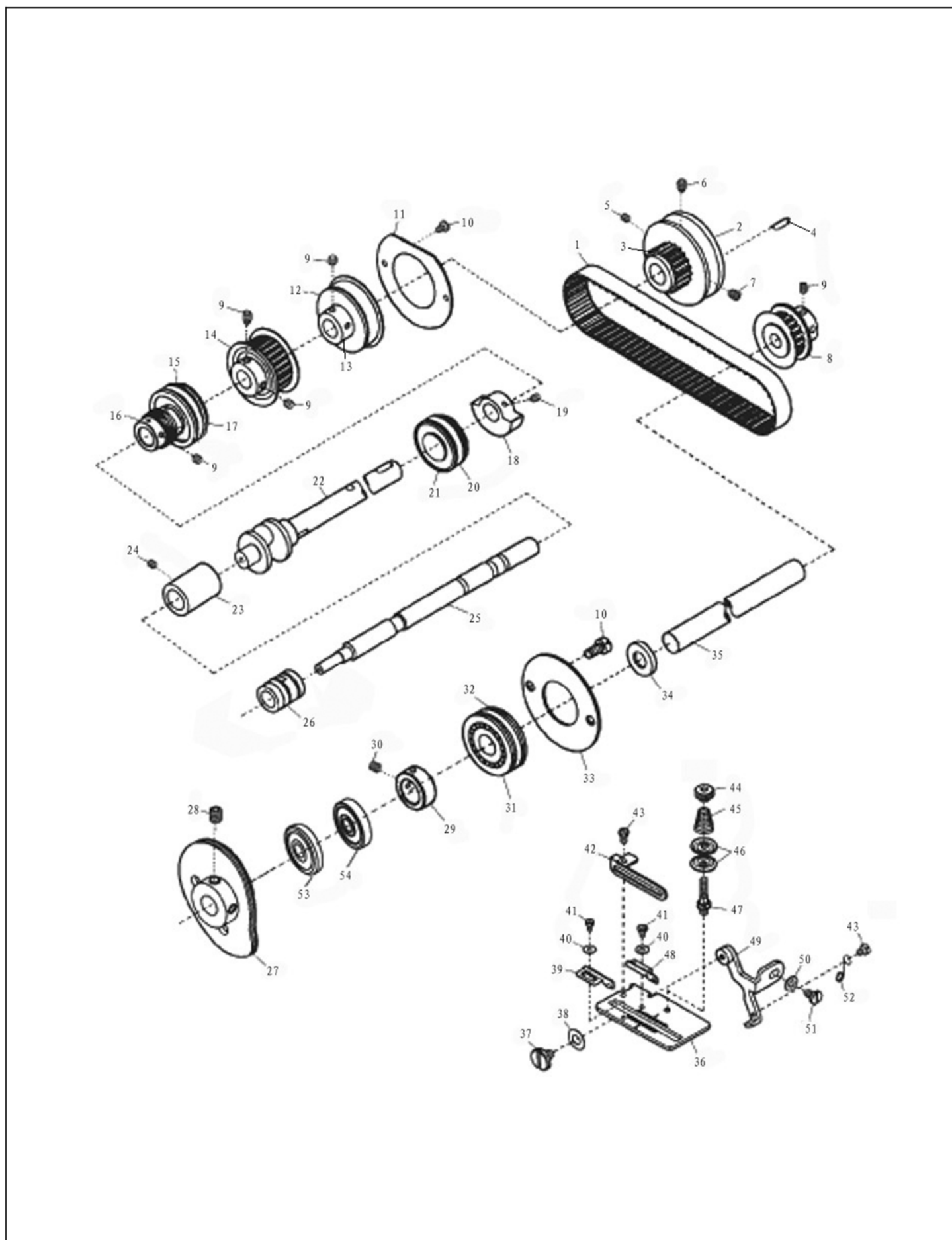

主轴部件

MAIN SHAFT DRIVING MECHANISM

序号 No.	件号 Pars No.	名称	Description	数量 Number
1	10008124	下过线同步齿形带	Timing Belt	1
2	10012826	从动轮	Pulley	1
3	10012827	下过线主动时规轮	Looper Thread Take-up Driving Sprocket	1
4	10003475	键	Pin	1
5	10009187	螺钉 (M6×8)	Screw (M6×8)	2
6	10012828	螺钉 (M6×5)	Screw (M6×5)	1
7	10012865	螺钉 (M6×4.5)	Screw (M6×4.5)	1
8	10014361	下过线从动时规轮组件	Looper Thread Take-up Shaft Sprocket	1
9	10011969	螺钉 (M6×5)	Screw (M6×5)	10
10	10014441	螺钉 (M4×6)	Screw (M4×6)	4
11	10014444	压紧环	Rear Cover	1
12	10025862	轴承	Ball Bearing	1
13	10012835	下轴后衬套	Ball Bearing Adapter	1
14	10012834	主动时规轮组件	Looper Thread Take-up Driving Sprocket	1
15	10025876	轴承	Ball Bearing	1
16	10011968	蜗杆	Oil Pump Driving Worm	1
17	10011923	O形圈	Seal Ring	2
18	10010955	上轴前接轴平衡块	Counterweight	1
19	10009074	螺钉 (M4×4)	Screw (M4×4)	2
20	10011805	O形圈	Seal Ring	2
21	10025877	轴承	Ball Bearing	1
22	10014438	下轴后节组件	Lower Grankshaft	1
23	10012862	下轴联轴器	Lower Shaft Joint	1
24	10012859	螺钉 (M5×3)	Screw (M5×3)	4
25	10023334	下轴前节组件	Lower Shaft	1
26	10012407	轴套	Bushing	1
27	10010475	打线凸轮组件	Looper Thread Take-up	1
28	10012162	螺钉 (M5×5)	Screw (M5×5)	2
29	10014442	挡圈	Collar	2
30	10014381	螺钉 (M5×2.6)	Screw (M5×2.6)	4
31	10014439	轴承	Ball Bearing	1
32	10014436	O形圈	Seal Ring	2
33	10014465	轴承止动环	Ball Bearing Cover	1
34	10014440	垫圈	Washer	1
35	10014434	下过线传动轴	Looper Thread Take-up Shaft	1
36	10014417	下过线座	Thread Take-up Eyelet Holder	1
37	10014411	螺钉 (M4)	Screw (M4)	1
38	10009470	垫圈	Washer	1
39	10014410	左下过线	Thread Take-up Eyelet (Left)	1
40	10003123	垫圈	Washer	2
41	10014413	螺钉 (M2.5×4)	Screw (M2.5×4)	2
42	10014414	下过线板	Looper Thread Guide	1
43	10012728	螺钉 (M3.5×4)	Screw (M3.5×4)	2
44	10004865	螺母	Nut	1
45	10004843	弹簧	Spring	1
46	10004866	绷线过线小夹线板	Looper Thread Supplementary Tension Disc	2
47	10004864	螺钉	Screw	1
48	10014412	右下过线	Thread Take-up Eyelet (Right)	1
49	10010215	下过线铰链支架组件	Thread Take-up Eyelet Bracket	1
50	10010761	垫圈	Washer	1
51	10011794	螺钉 (M4×10)	Screw (M4×10)	1
52	10012868	弹簧	Spring	1
53	10025873	轴承	Ball Bearing	1
54	10025872	轴承	Ball Bearing	1

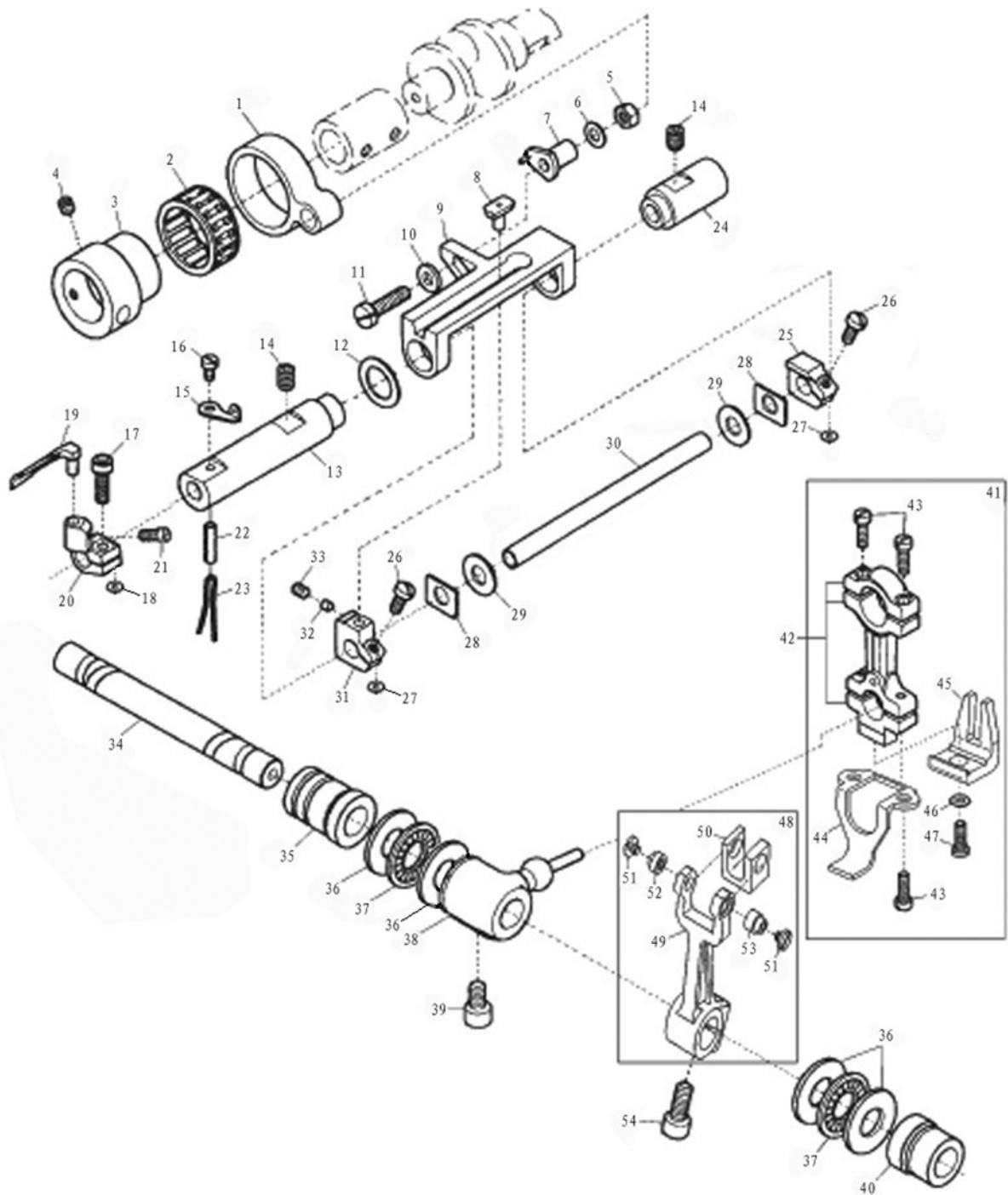

## 弯针部件

## LOOPER DRIVING MECHANISM

序号 No.	件号 Pars No.	名称	Description	数量 Number
1	10010461	弯针凸轮连杆	Looper Rocker Connecting Rod	1
2	10007406	轴承	Roller Bearing	1
3	10014466	弯针凸轮	Looper Rocker Regulating Eccentric	1
4	10012162	螺钉 (M5×5)	Screw (M5×5)	2
5	10009467	螺母	Nut	1
6	10010459	垫圈	Washer	1
7	10013842	弯针调节柱组件	Looper Rocker Adjusting Pin	1
8	10012741	弯针导架	Slider	1
9	10010462	弯针传动座	Slider Holder	1
10	10010466	垫圈	Washer	1
11	10010249	螺钉 (M5×28.2)	Screw (M5×28.2)	1
12	10012747	垫圈	Washer	1
13	10014373	轴套	Bushing	1
14	10009187	螺钉 (M6×8)	Screw (M6×8)	2
15	10014472	弯针过线板	Looper Thread Eyelet	1
16	10010467	螺钉 (M3.5×4)	Screw (M3.5×4)	1
17	10012752	螺钉 (M4×10)	Screw (M4×10)	1
18	10012756	垫圈	Washer	1
19	10012780	弯针	Looper	1
20	10012743	弯针座	Looper Holder	1
21	10012032	螺钉 (M4×7)	Screw (M4×7)	1
22	10002848	销	Pin	1
23	10024499	油线 $\phi 2 \times 44$	Oil Wick	1
24	10012406	轴套	Bushing	1
25	10012745	弯针轴右挡块	Rocker Arm, Holder	1
26	10013178	螺钉 (M4×12)	Screw (M4×12)	2
27	10012756	垫圈	Washer	2
28	10012786	垫圈	Washer	2
29	10012784	垫圈	Washer	2
30	10027629	弯针轴	Looper Bar	1
31	10014473	弯针轴左挡块	Slider Holder	1
32	10012751	弯针导架螺钉压块	Slider Presser	1
33	10009074	螺钉 (M4×4)	Screw (M4×4)	1
34	10014369	弯针横轴组件	Looper Shaft	1
35	10012411	轴套	Bushing	1
36	10012782	垫圈	Washer	4
37	10007849	轴承	Roller Bearing	2
38	10005592	弯针球曲柄	Looper Driving Lever	1
39	10012024	螺钉 (M6×15)	Screw (M6×15)	1
40	10012405	轴套	Bushing	1
41	10005594	弯针连杆组件	Looper Connecting Rod, Complete Set	1
42	10005591	弯针连杆	Looper Connecting Rod	1
43	10005593	螺钉 (M4×12)	Screw (M4×12)	4
44	10014437	连杆打油板	Oil Splasher	1
45	10004829	叉板	Guide Fork	1
46	10002991	垫圈	Washer	1
47	10011967	螺钉 (M4×9)	Screw (M4×9)	1
48	10010255	弯针横轴摆杆组件	Loop Rocker Arm, Complete Set	1
49	10004020	弯针横轴摆杆	Loop Rocker Arm	1
50	10004029	弯针横轴摆杆滑块	Slider Block	1
51	10010217	螺钉 (M3×3.3)	Screw (M3×3.3)	2
52	10010248	弯针横轴摆杆滑块短销	Pin	1
53	10010246	弯针横轴摆杆滑块长销	Pin	1
54	10012024	螺钉 (M6×15)	Screw (M6×15)	1

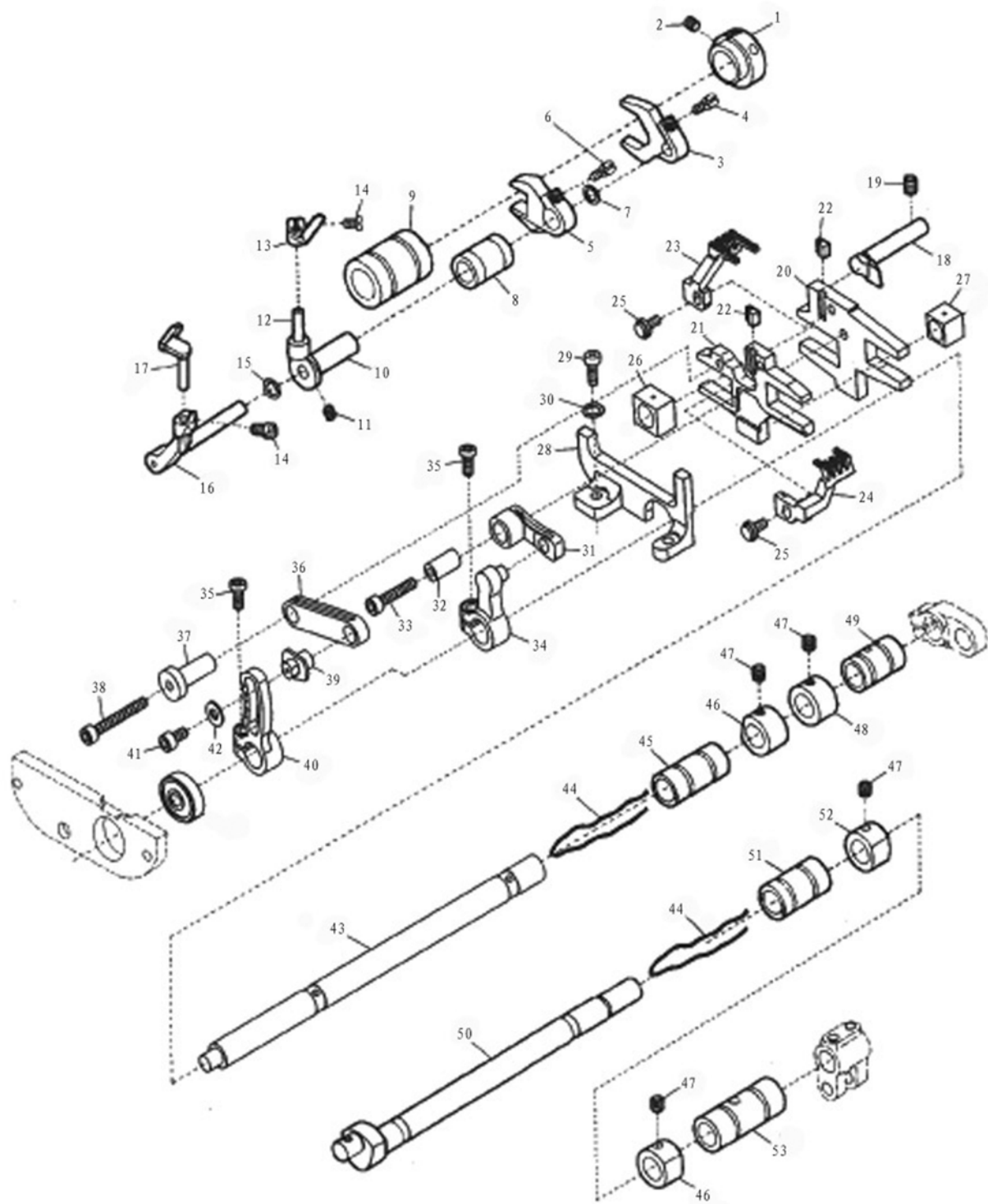



## 差动送布部件

## FEED DRIVING MECHANISM

序号 No.	件号 Pars No.	名称	Description	数量 Number
1	10012772	保针凸轮	Needle Guard(Front) Eccentric	1
2	10012162	螺钉 (M5×5)	Screw (M5×5)	2
3	10012769	外保针牙叉	Needle Guard(Rear) Lever	1
4	10009115	螺钉 (M3.5×8)	Screw (M3.5×8)	1
5	10012767	内保针牙叉	Needle Guard(Front) Lever	1
6	10012763	螺钉 (M3.5×12)	Screw (M3.5×12)	1
7	10012830	垫圈	Washer	1
8	10012403	轴套	Bushing	1
9	10012412	轴套	Bushing	1
10	10027637	内保针曲柄	Needle Guard(Front) Holder	1
11	10012773	螺钉 (M3.5×3)	Screw (M3.5×3)	1
12	10012771	销	Pin	1
13	10012832	内保针	Needle Guard(Rear)	1
14	10012738	螺钉 (M3.5×6.5)	Screw (M3.5×6.5)	2
15	10012830	垫圈	Washer	1
16	10012736	外保针曲柄	Needle Guard(Front) Holder	1
17	10012829	外保针	Needle Guard(Front)	1
18	10012831	牙架右限位块	Feed Lift Block	1
19	10009187	螺钉 (M6×8)	Screw (M6×8)	1
20	10005171	送布牙架	Main Feed Bar	1
21	10004013	差动牙架	Differential Feed Bar	1
22	10005866	送料牙安装座	Feed Dog Key	2
23	*	送料牙	Main Feed Dog	1
24	*	差动牙	Differential Feed Dog	1
25	10011733	螺钉 (SM9/64"×40)	Screw (SM9/64"×40)	2
26	10012864	牙架后滑块	Feed Lift Block (Front)	1
27	10012690	牙架前滑块	Feed Lift Block (Rear)	1
28	10010212	牙架外挡板	Feed Bar Guide	1
29	10012752	螺钉 (M4×10)	Screw (M4×10)	2
30	10002954	垫圈	Washer	2
31	10010247	送料连杆	Main Feed Bar Driving Connection	1
32	10010213	送料连杆销	Pin	1
33	10010214	螺钉 (M4×19)	Screw (M4×19)	1
34	10010251	送料曲柄	Main Feed Rocker Lever	1
35	10012752	螺钉 (M4×10)	Screw (M4×10)	2
36	10010250	差动连杆	Differential Feed Bar Driving Connection	1
37	10010253	差动连杆销	Pin	1
38	10010216	螺钉 (M4×28)	Screw (M4×28)	1
39	10010252	差动调节曲柄滑块	Differential Feed Adjusting Pin	1
40	10010254	差动调节曲柄	Differential Feed Rocker Lever	1
41	10012553	螺钉 (M4×8)	Screw (M4×8)	1
42	10011055	垫圈	Washer	1
43	10012252	送布轴	Feed Rocker Shaft	1
44	10008066	油线 $\phi 2.5 \times 260$	Oil Wick	2
45	10012404	轴套	Bushing	1
46	10012691	挡圈	Collar	2
47	10012014	螺钉 (M5×4)	Screw (M5×4)	4
48	10012693	挡圈	Collar	1
49	10012410	轴套	Bushing	1
50	10005887	抬牙送布轴	Feed Lift Shaft	1
51	10012508	轴套	Bushing	1
52	10012643	挡圈	Collar	1
53	10012408	轴套	Bushing	1

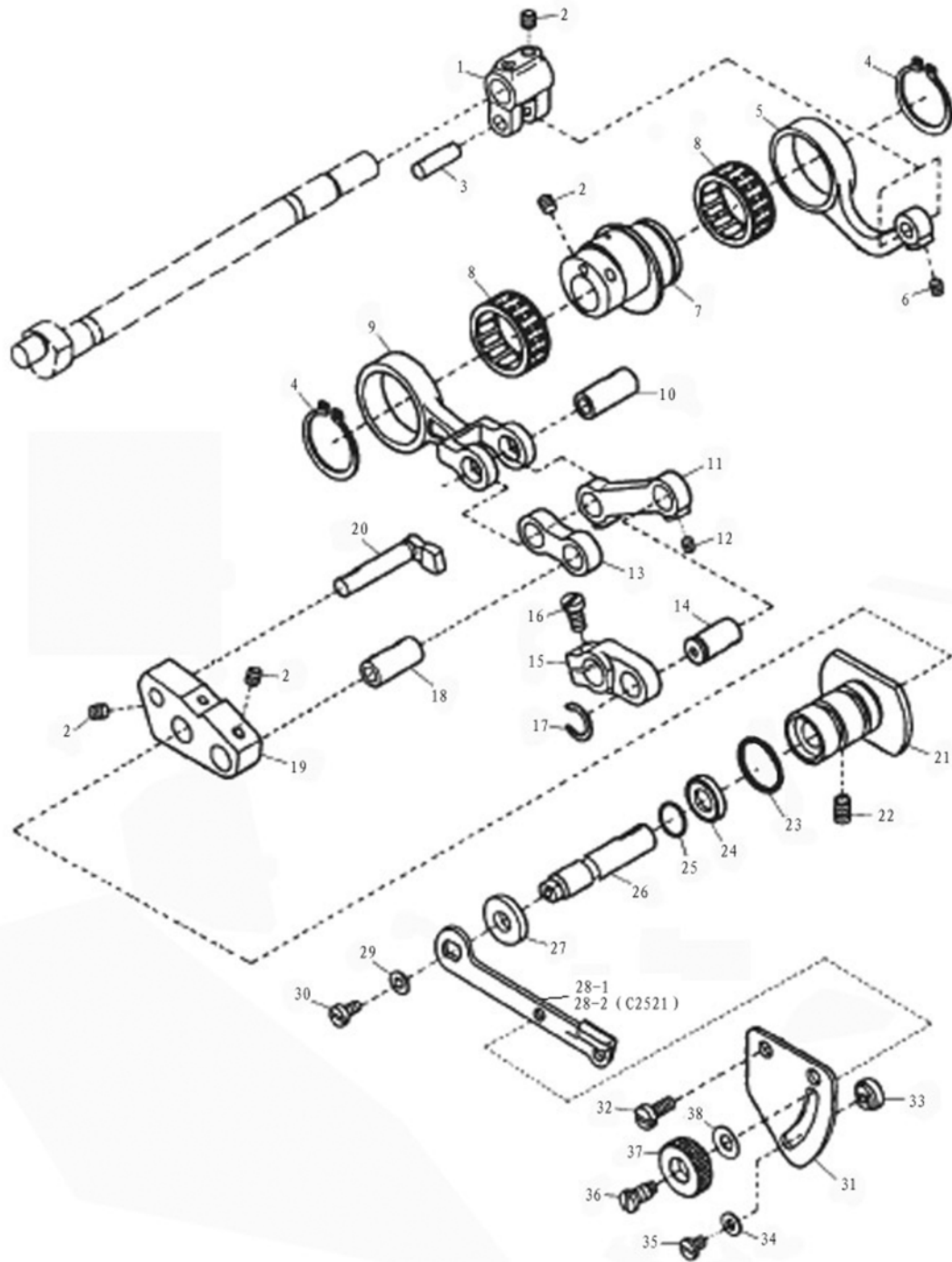

## 差动调节部件

## FEED DRIVING CONTROL MECHANISM

序号 No.	件号 Pars No.	名称	Description	数量 Number
1	10012792	抬牙轴连杆座	Feed Lift Lever	1
2	10012162	螺钉(M5×5)	Screw(M5×5)	7
3	10012781	抬牙轴连杆座销	Pin	1
4	10003238	挡圈	Collar	2
5	10012789	抬牙轴连杆	Feed Lift Connecting Rod	1
6	10009074	螺钉(M4×4)	Screw(M4×4)	1
7	10012791	差动抬牙凸轮	Feed Eccentric	1
8	10007371	轴承	Roller Bearing	2
9	10012788	差动器连杆	Feed Connecting Rod	1
10	10012481	差动器连杆销	Pin	1
11	10012783	差动器连杆长连杆	Lever Link	1
12	10012778	螺钉(M4×4)	Screw(M4×4)	2
13	10012779	差动器连杆短连杆	Lever Link	1
14	10012515	差动器连杆长短连杆销轴	Lever Link Pin	1
15	10012790	差动轴连杆	Feed Shaft Lever	1
16	10012793	螺钉(M5×10)	Screw(M5×10)	1
17	10012519	挡圈	Collar	1
18	10012481	差动器连杆销	Pin	1
19	10012518	差动器座	Control Bracker	1
20	10012521	差动器连杆限位块	Connecting Rod Guide	1
21	10012333	差动器衬套	Control Lever Shaft Bushing	1
22	10009187	螺钉(M6×8)	Screw(M6×8)	1
23	10012513	O形圈	O-Ring	1
24	10014443	油封	Oil Seal	1
25	10009608	O形圈	O-Ring	1
26	10010532	差动调节销轴	Control Lever Shaft	1
27	10012487	垫圈	Washer	1
28-1	10010498	针距调节拉杆	Feed Connecting Lever	1
28-2	10009714	针距调节拉杆	Feed Connecting Lever	1
29	10010111	垫圈	Washer	1
30	10010594	螺钉(M4×7.5)	Screw(M4×7.5)	1
31	10010501	差动调节板组件	Feed Graduation	1
32	10012480	螺钉(M4×12.5)	Screw(M4×12.5)	2
33	10012516	螺母	Nut	1
34	10011653	垫圈	Washer	1
35	10014441	螺钉(M4×6)	Screw(M4×6)	1
36	10010856	螺钉	Screw	1
37	10010491	针距调节锁紧螺母	Nut	1
38	10010861	垫圈	Washer	1

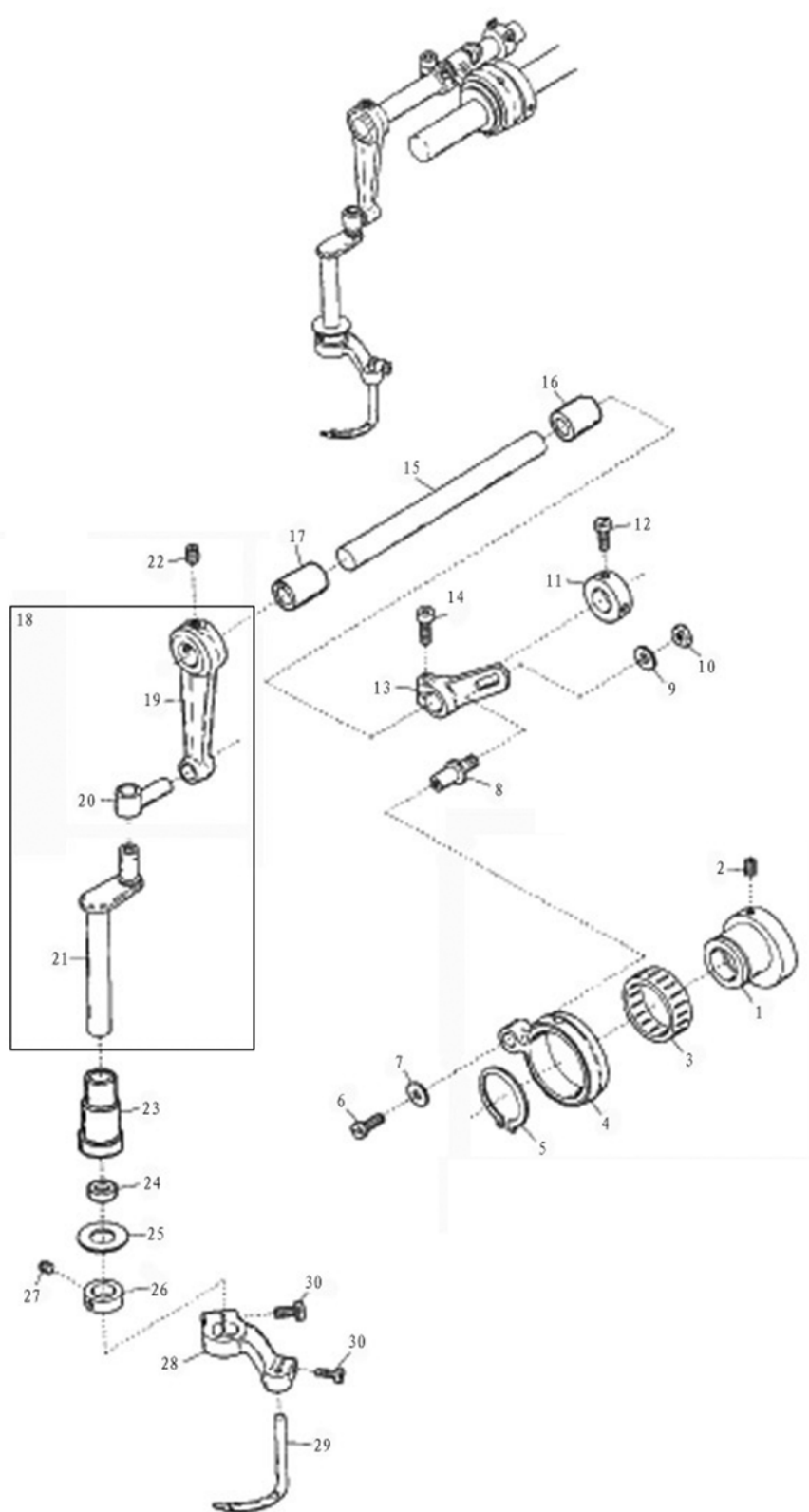

绷针部件

SPREADER MECHANISM

序号 No.	件号 Pars No.	名称	Description	数量 Number
1	10011074	绷针偏心轮	Eccentric	1
2	10012162	螺钉 (M5×5)	Screw (M5×5)	2
3	10007400	轴承	Roller Bearing	1
4	10011071	偏心轮连杆	Connecting Rod	1
5	10011076	挡圈	Collar	1
6	10011005	螺钉 (M4×9)	Screw (M4×9)	1
7	10011055	垫圈	Washer	1
8	10011053	调整曲柄销	Pin	1
9	10012393	垫圈	Washer	1
10	10003084	螺母	Nut	1
11	10013016	挡圈	Collar	1
12	10013015	螺钉 (SM11/64"×40)	Screw (SM11/64"×40)	1
13	10011073	绷针调整曲柄	Adjusting Lever	1
14	10009008	螺钉 (M6×16)	Screw (M6×16)	1
15	10011658	绷针轴	Driving Shaft	1
16	10011116	轴套	Bushing	1
17	10011106	轴套	Bushing	1
18	10007588	绷针曲柄轴连杆组件	Needle Bar Rocking Arm, Complete Set	1
19	10011666	绷针轴连杆	Rocking Arm	1
20	10011651	绷针连接柱	Rocking Pin	1
21	10011656	绷针曲柄轴	Spreader Bar	1
22	10010907	螺钉 (M6×6)	Screw (M6×6)	2
23	10011110	轴套	Bushing	1
24	10011657	油封	Oil Seal	1
25	10011665	垫圈	Washer	1
26	10011722	挡圈	Collar	1
27	10011887	螺钉 (SM9/64"×40)	Screw (SM9/64"×40)	2
28	10011659	绷针摆动曲柄	Spreader Holder	1
29	10011662	绷针	Spreader	1
30	10009037	螺钉 (M4×12)	Screw (M4×12)	2

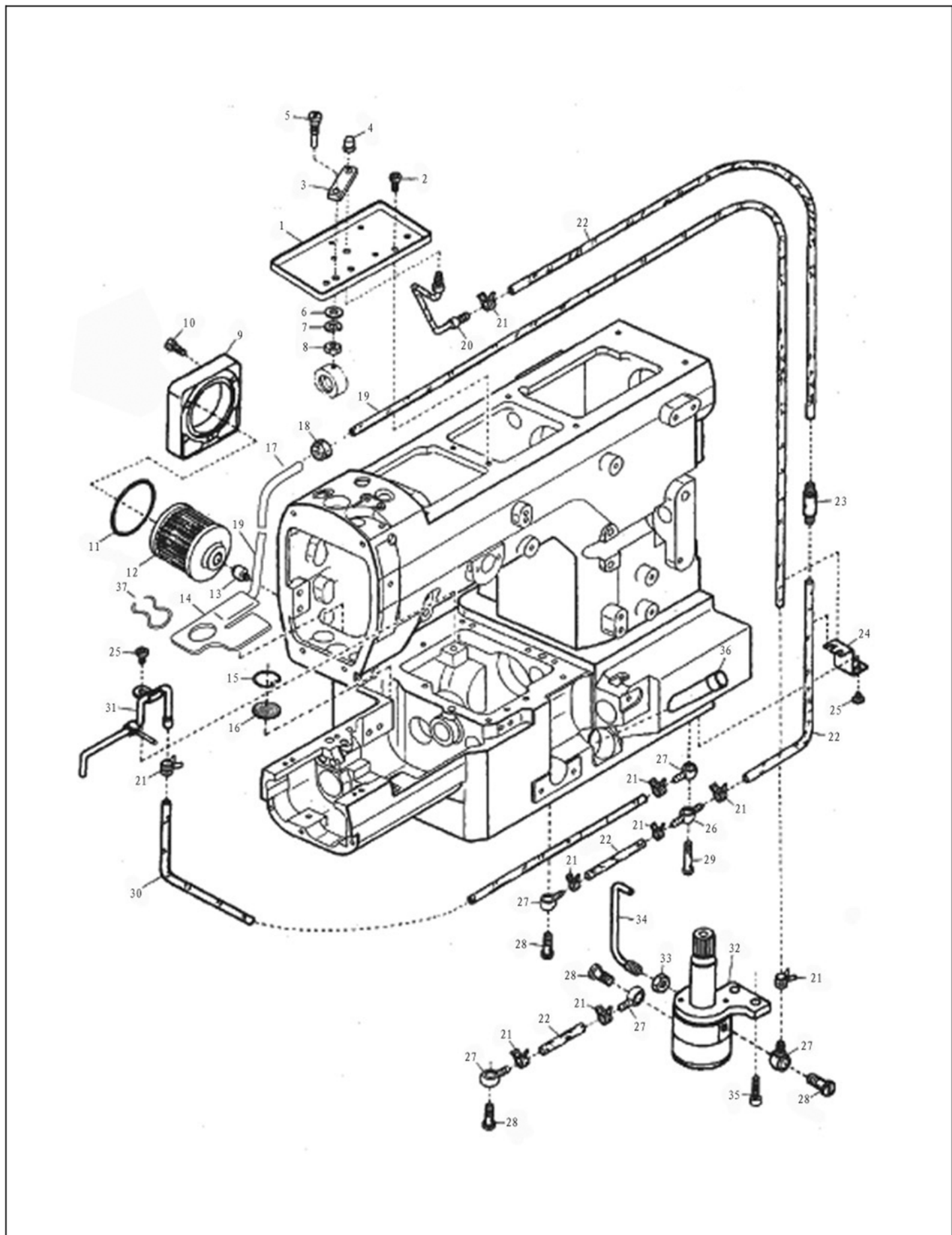

润滑部件

LUBRICATING MECHANISM

序号 No.	件号 Pars No.	名称	Description	数量 Number
1	10011465	上轴喷油分布盘	Oil Receiver	1
2	10010837	螺钉 (M4×5)	Screw (M4×5)	2
3	10011468	上轴两孔通油板	Lubricant Guiding Block	1
4	10011467	上轴喷油管嘴	Top Nozzle	1
5	10011464	螺钉 (M5)	Screw (M5)	1
6	10011653	垫圈	Washer	1
7	10005537	垫圈	Washer	1
8	10009467	螺母	Nut	1
9	20003647	滤油器盖	Oil Filter Cap	1
10	10012710	螺钉 (M4×14)	Screw (M4×14)	3
11	10003793	O形圈	O-Ring	1
12	10014236	滤油器组件	Oil Filter	1
13	10012104	螺钉 (M10×7)	Screw (M10×7)	1
14	10012328	回油毡	Felt	1
15	10003280	挡圈	Collar	1
16	10010777	过滤网	Oil Filter Screen	1
17	10012331	回油管	Suction Pipe	1
18	10012092	橡胶塞	Seal Pulg	1
19	10007795	油管 $\phi 3.5 \times \phi 5 \times 510$	Oil Tube	1
20	10011461	上轴喷油管组件	Oil Pipe Unit	1
21	10011471	进油短油管夹	Oil Tube Clam	9
22	10007796	油管 $\phi 4 \times \phi 6 \times 400$	Oil Tube	1
23	10014235	单向阀组件	Non-return Valve Unit	1
24	10012808	油管挡板	Oil Tube Stay	1
25	10014441	螺钉 (M4×6)	Screw (M4×6)	3
26	10012095	油泵进油分流管接头	Oil Tube Joint, Two Way	1
27	10012103	管接头	Oil Tube Joint, One Way	5
28	10012084	螺钉 (SM1/4"×40)	Screw (SM1/4"×40)	4
29	10012102	螺钉 (SM1/4"×40)	Screw (SM1/4"×40)	1
30	10007796	油管 $\phi 4 \times \phi 6 \times 160$	Oil Tube	1
31	10012805	弯针机构供油管组件	Lower Shaft Oiling Shower	1
32	10007770	油泵组件	Oil Pump	1
33	10012107	螺母	Nut	1
34	10011460	回油出油管组件	Oil Nozzle For Worm Gear	1
35	10011313	螺钉 (M6×12)	Screw (M6×12)	2
36	10012871	油标	Oil Sight Gauge Oil Receiver	1
37	10012332	回油毡夹	Felt Clam	1

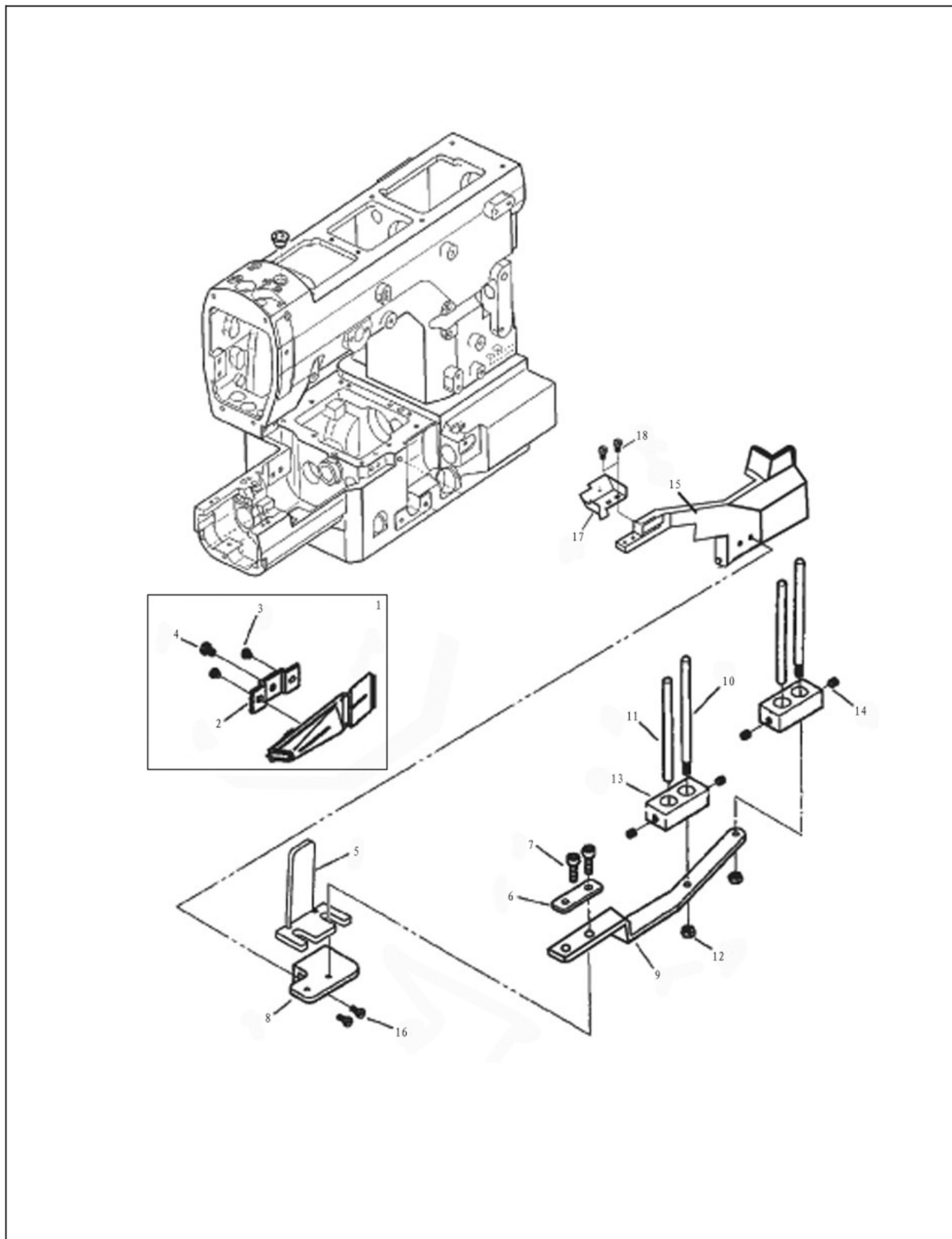





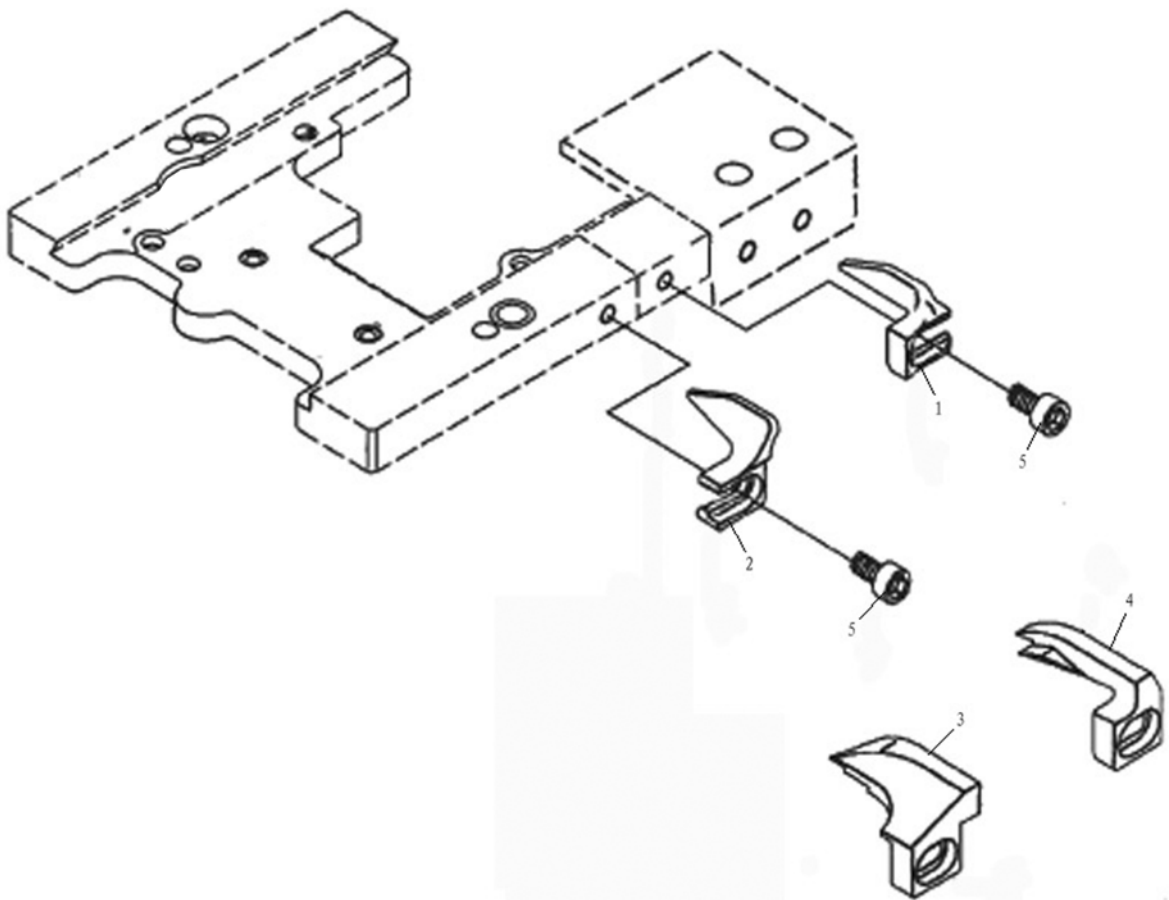



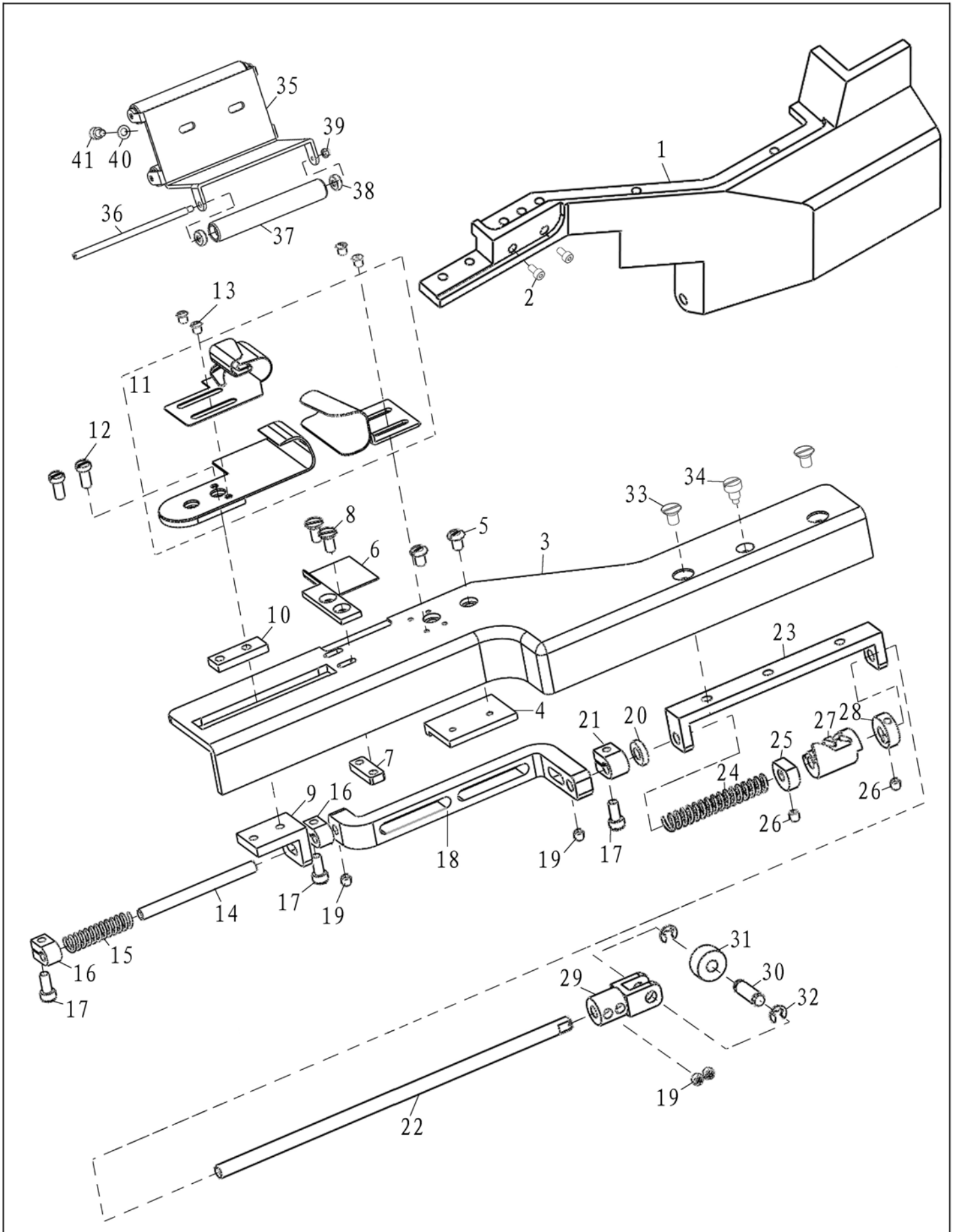

氨纶专用零部件(1)

Urethane Stitch EXCLUSIVE PARTS(1)

序号 No.	件号 Pars No.	名称	Description	数量 Number
1	20003621	穿线罩板		1
2	10012553	M4×8螺钉		2
3	10012568	座板		1
4	10012560	安装座		1
5	10014474	SM11/64"×40螺钉		2
6	10014475	挡布板		1
7	10014455	螺母		1
8	10014458	M4×12螺钉		2
9	10014457	滑块座		1
10	10014451	滑块		1
11	10025049	包缝板组件		1
12	10011798	M4×10螺钉		2
13	10014454	M3.5×4螺钉		4
14	10012561	短顶杆		1
15	10012566	弹簧		1
16	10012559	短顶杆定位块		2
17	10012752	M4×10螺钉		3
18	10012565	连接杆		1
19	10012014	M5×4螺钉		4
20	10012523	垫圈		1
21	10012564	长顶杆定位块		1
22	10012522	长顶杆		1
23	10012558	导向座		1
24	10012562	弹簧		1
25	10012567	挡圈		1
26	10011802	SM11/64"×40螺钉		4
27	10012557	定位器		1
28	10012563	右紧圈组件		1
29	10014450	顶杆头		1
30	10012802	顶轮轴		1
31	10014456	顶轮		1
32	10009653	挡圈		2
33	10014453	M5×8.7螺钉		2
34	10014476	螺钉		1
35	20003677	中轮座板		1
36	10012656	中过布轮轴		3
37	10012650	中过布轮		3
38	10003575	轴承		6
39	10012658	螺母		3
40	10004936	垫圈		2
41	10003105	M6×8螺钉		2

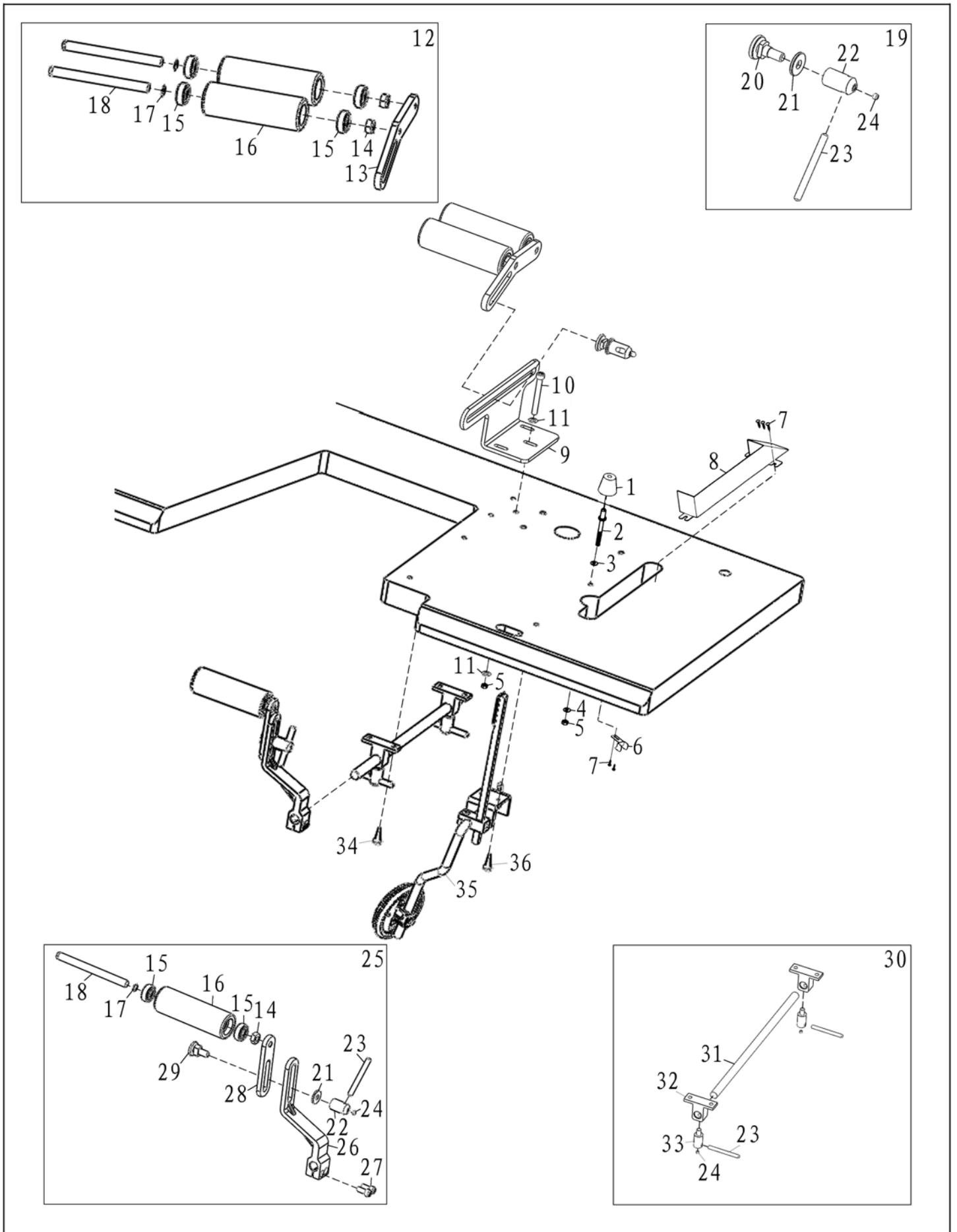

氨纶专用零部件(2)

Urethane Stitch EXCLUSIVE PARTS (2)

序号 No.	件号 Pars No.	名称	Description	数量 Number
1	10011315	防震垫		4
2	10012704	M6×57螺钉		4
3	10012701	垫圈		8
4	10003077	垫圈		4
5	10002994	螺母		7
6	10011309	挡链板		1
7	10008323	螺钉		7
8	20003667	台板防护罩		1
9	20003680	前过布轮支座		1
10	10003790	M6×55螺钉		3
11	10004936	垫圈		6
12	20001519	前过布轮组件		1
13	10012602	前轮座板		1
14	10012605	螺母		3
15	10025874	轴承		6
16	10012604	前过布轮		3
17	10003277	挡圈		3
18	10012655	前轮轴		3
19	20001526	前轮夹紧装置		1
20	10012651	前轮夹紧块		1
21	10012652	垫圈		2
22	10012657	螺母		2
23	10012649	夹紧手柄		4
24	10012014	M5×4螺钉		4
25	20001527	后过布轮组件		1
26	10012648	后过布轮支架		1
27	10009008	M6×16螺钉		2
28	10012603	后轮座板		1
29	10012653	后轮夹紧块		1
30	20001528	前轮安装座		1
31	10012711	接杆		1
32	10012700	固定座		2
33	10012712	螺钉		2
34	10003181	螺钉		4
35	10013939	操纵杆组件		1
36	10008323	螺钉		2

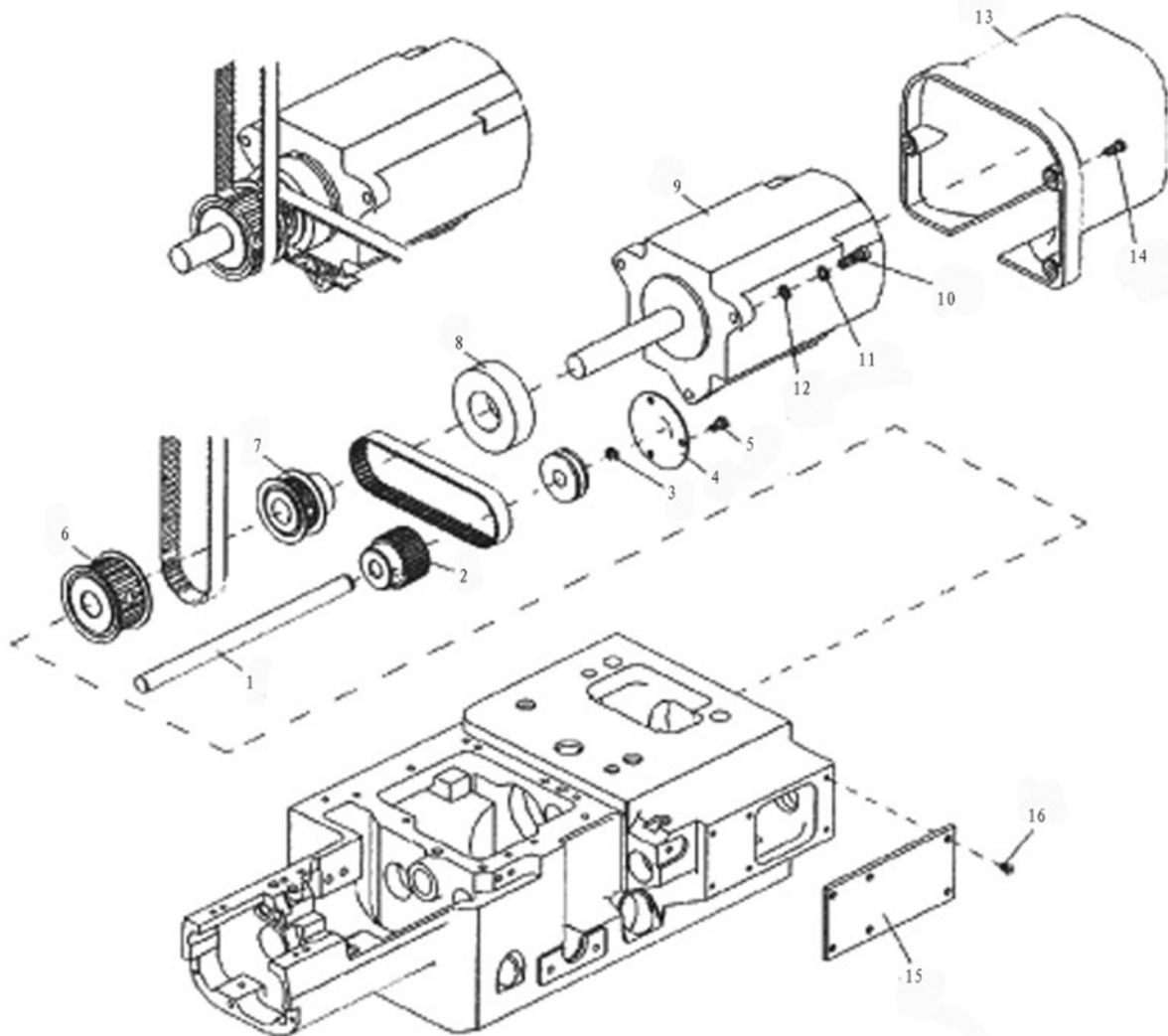





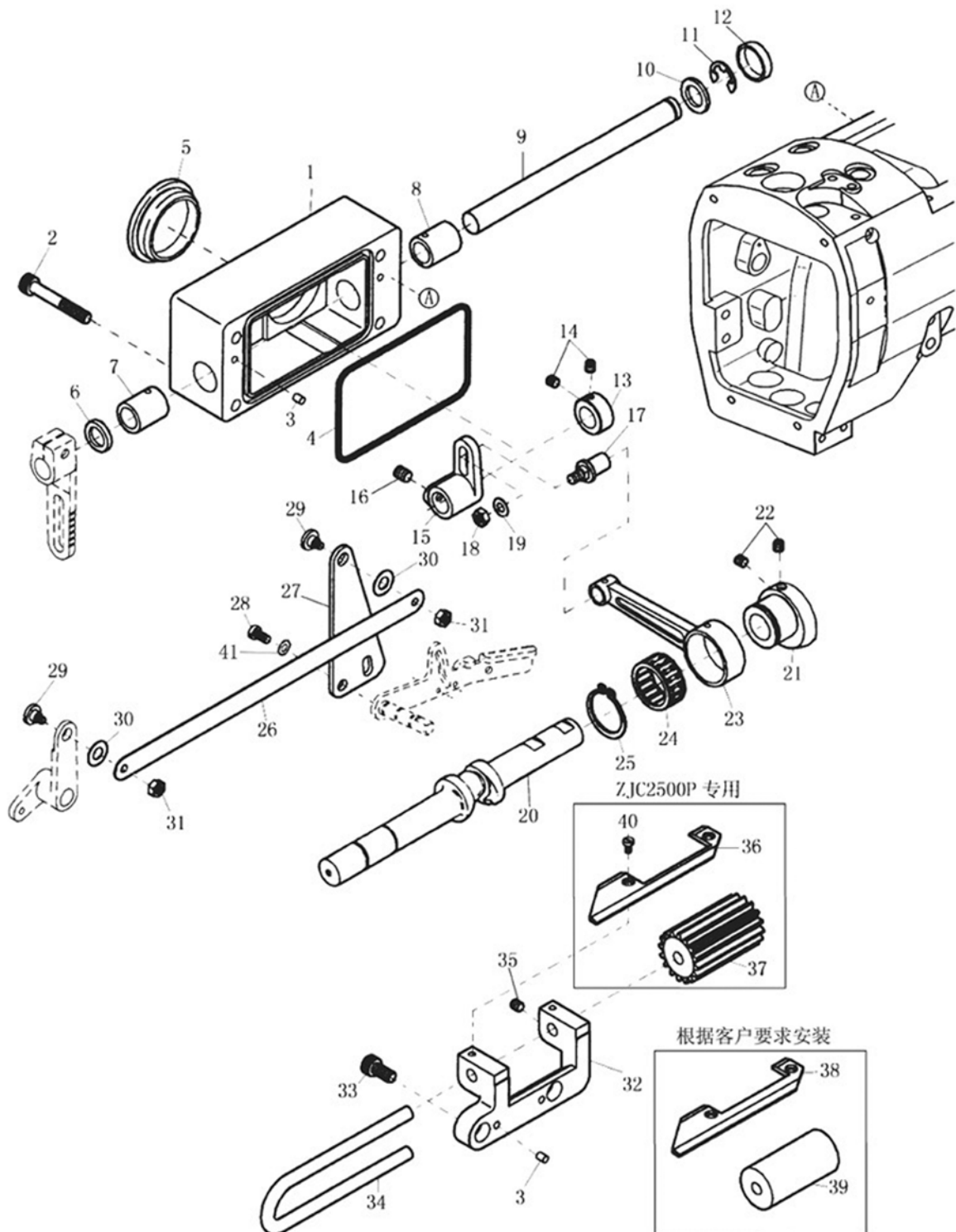

## 拖布轮专用件(1)

## UPPER FEED ROLLER EXCLUSIVE PARTS(1)

序号 No.	件号 Pars No.	名称	Description	数量 Number
1	20003688	拖布轮轴架	Upper Feed Roller Shaft Bracket	1
2	10010233	螺钉(M6×41)	Screw(M6×41)	4
3	10012319	销	Pin	4
4	10010276	密封圈	Gasket	1
5	10010266	油塞	Seal Plug	1
6	10010577	油封	Oil Seal	1
7	10010574	轴套	Bushing	1
8	10010572	轴套	Bushing	1
9	10010275	拖布轮轴	Upper Feed Roller Shaft	1
10	10010265	挡圈	Washer	1
11	10003281	挡圈	Retaining Ring	1
12	10011186	油封	Oil Seal	1
13	10011284	挡圈	Collar	1
14	10012014	螺钉(M5×4)	Screw(M5×4)	2
15	10010571	拖布轮轴上曲柄	Upper Feed Roller Shaft Lever	1
16	10009187	螺钉(M6×8)	Screw(M6×8)	2
17	10010576	上曲柄调节销	Pin	1
18	10009467	螺母	Nut	1
19	10003073	垫圈	Washer	1
20	10004038	上轴前节轴	Upper Crankshaft	1
21	10010232	拖布轮偏心轮	Upper Feed Roller Eccentric	1
22	10012162	螺钉(M5×5)	Screw(M5×5)	4
23	10010195	拖布轮轴上连杆	Upper Feed Roller Lever Rod	1
24	10021300	轴承	Bearing	1
25	10003282	挡圈	Retaining Ring	1
26	10010219	连接片	Lifter Connecting Plate	1
27	10010230	拖布轮右曲柄	Upper Feed Roller Lifter	1
28	10009556	螺钉(M4×7)	Screw(M4×7)	2
29	10010223	螺钉(M4×3.3)	Screw(M4×3.3)	2
30	10010231	垫片	Washer	2
31	10009471	螺母	Nut	2
32	20003721	拖布轮下轮支架	Feed Roller Yoke	1
33	10003402	螺钉(M6×10)	Screw(M6×10)	2
34	10010228	拖布轮下轮轴	Feed Roller Shaft	1
35	10012323	下轮支架罩板B	Plate(B)	1
36	10014198	拖布轮下轮B	Feed Roller(B)	1
37	10012330	下轮支架罩板A	Plate(A)	1
38	10012327	拖布轮下轮A	Feed Roller(A)	1
39	10009600	螺钉(M3×6)	Screw(M3×6)	2
40	10003083	垫圈	Washer	2

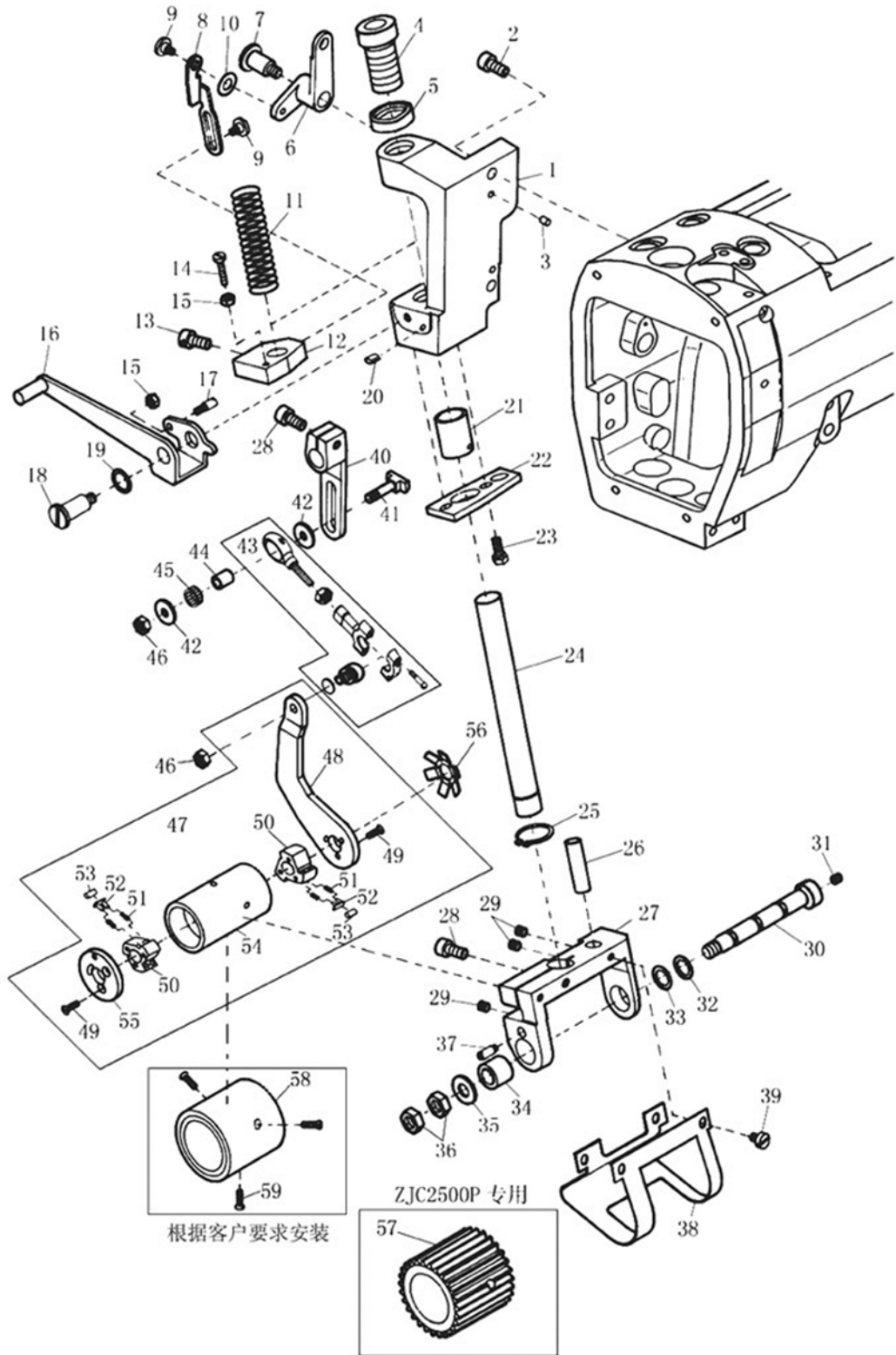

## 拖布轮专用件(2)

## UPPER FEED ROLLER EXCLUSIVE PARTS(2)

序号 No.	件号 Pars No.	名称	Description	数量 Number
1	20003689	拖布轮压杆支架	Upper Feed Roller Yoke Bracket	1
2	10008982	螺钉(M6×16)	Screw(M6×16)	2
3	10012319	销	Pin	2
4	10010575	螺钉	Screw	1
5	10010573	螺母	Nut	1
6	10010225	拖布轮左曲柄	Upper Feed Roller Lifter	1
7	10010268	螺钉(M6×8)	Screw(M6×8)	1
8	10012321	左曲柄连接板	Lifter Connecting Plate	1
9	10010193	螺钉(M4×3.3)	Screw(M4×3.3)	2
10	10010231	垫片	Washer	2
11	10010194	调压簧	Spring	1
12	10010227	压杆导架	Roller Press Bar Bracket	1
13	10009008	螺钉(M6×16)	Screw(M6×16)	2
14	10012089	螺钉(M4×25)	Screw(M4×25)	1
15	10009471	螺母	Nut	3
16	10010226	拖布轮手柄组件	Upper Feed Roller Lifting Lever C. Set	1
17	10010224	螺钉(M4×7)	Screw(M4×7)	1
18	10010192	螺钉(M6×8)	Screw(M6×8)	1
19	10010218	垫圈	Washer	1
20	10002772	销	Pin	1
21	10010533	轴套	Bushing	1
22	10010221	支架压板	Roller Press Bar Bracket	1
23	10009349	螺钉(M5×9.8)	Screw(M5×9.8)	2
24	10010222	拖布轮压杆	Upper Feed Roller Press Bar	1
25	10003334	挡圈	Retaining Ring	1
26	10010220	拖布轮支架销	Upper Feed Roller Yoke Pin	1
27	10010229	拖布轮上轮支架	Upper Feed Roller Yoke	1
28	10012162	螺钉(M5×5)	Screw(M5×5)	3
29	10010477	离合器轴	Clutch Driving Shaft	1
30	10011803	螺钉(M5×6)	Screw(M5×6)	1
31	10010478	垫圈	Ring	1
32	10010480	垫圈	Ring	1
33	10010479	轴套	Bushing	1
34	10003031	垫圈	Ring	1
35	10003131	螺母	Nut	2
36	10012325	螺钉(M4×3.5)	Screw(M4×3.5)	1
37	10010476	拖布轮支架罩	Feed Cover	1
38	10002957	螺钉(M5×6)	Screw(M5×6)	4
39	10010264	拖布轮轴下曲柄	Upper Feed Roller Lever	1
40	10010272	下曲柄调节销	Upper Feed Roller Lever Pin	1
41	10010954	垫圈	Washer	2
42	10013893	拖布轮轴下连杆组件	Feed Roller Rod C. Set	1
43	10010267	下曲柄调节销内套	Bushing	1
44	10021304	轴承	Bearing	1
45	10009467	螺母	Nut	2
46	10010273	离合器组件	Clutch C. Set	1
47	10010274	垫圈	Washer	1
48	10014195	拖布轮上轮B	Upper Feed Roller(B)	1
49	10012326	拖布轮上轮A	Upper Feed Roller(A)	1
50	10012480	螺钉(M4×12.5)	Screw(M4×12.5)	3
51	10003073	垫圈	Washer	4
52	10012080	螺钉(M4×20)	Screw(M4×20)	1

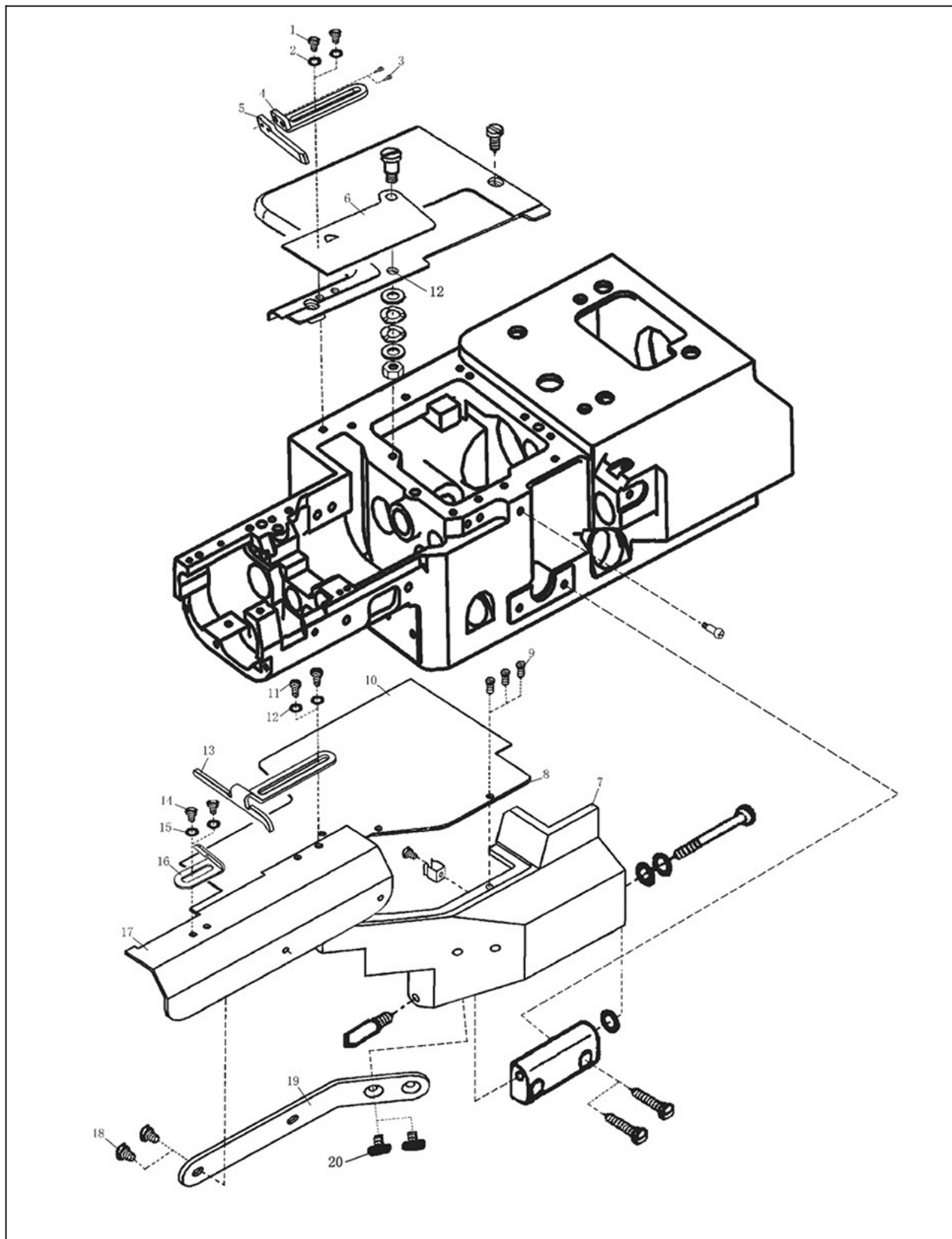

## 左切刀专用件(1)

## LEFT-COUNTER EXGLUSIVE PART(1)

序号 No.	件号 Pars No.	名称	Description	数量 Number
1	10013161	螺钉(M3.5×7)	Screw(M3.5×7)	2
2	10003083	垫圈	Washer	2
3	10011670	螺钉(M2.5×4.5)	Screw(M2.5×4.5)	2
4	10012246	后挡布板安装座	Fixing Board	1
5	10013454	后挡布板	Back Cloth Guide Plate	1
6	10010500	上罩板摇板	Upper Cover Swing Board	1
7	20003668	穿线罩板	Front Cover	1
8	10006833	穿线罩板盖组件	Front Cover(Upper)	1
9	10012642	螺钉(M3.5×7)	Screw(M3.5×7)	3
10	10012512	螺钉(M3.5×5.8)	Screw(M3.5×5.8)	6
11	10003083	垫圈	Washer	4
12	10013453	右挡布板	Cloth Guide Plate(right)	1
13	10012257	左挡布板	Cloth Guide Plate(left)	1
14	10012211	螺钉(M3.5×4)	Screw(M3.5×4)	2
15	10012258	穿线罩加强板	Front Cover Strengthen Hdder	1

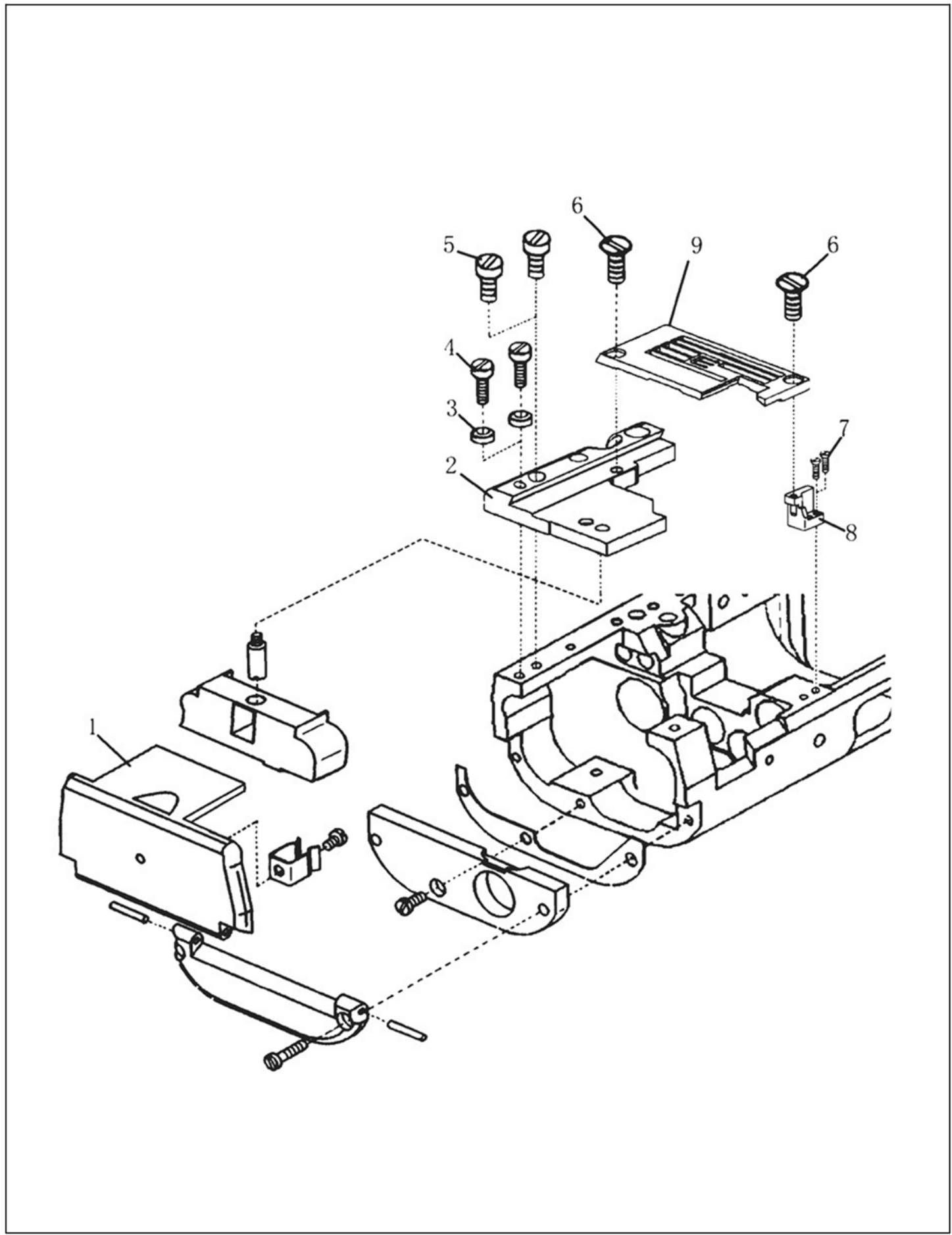





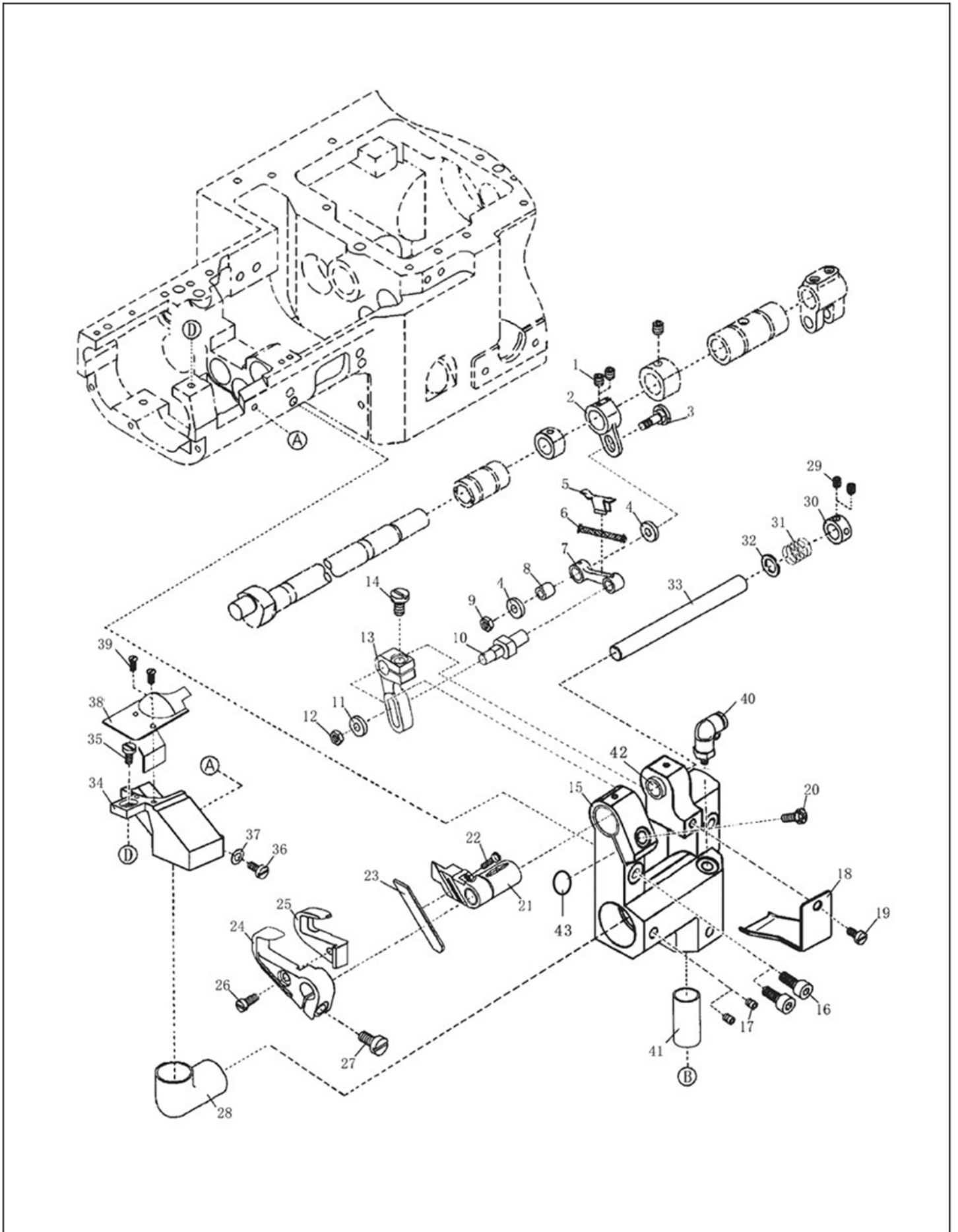

## 左切刀专用件(3)

## LEFT-COUNTER EXCLUSIVE PART(3)

序号 No.	件号 Pars No.	名称	Description	数量 Number
1	10012014	螺钉(M5×4)	Screw(M5×4)	2
2	10009754	传动曲柄	Connecting Crank	1
3	10009722	曲柄调节螺钉	Screw	1
4	10011055	垫圈	Washer	2
5	10009723	油芯夹	Oil Core Damp	1
6	10008075	油线φ2×28	Oil Core	1
7	10009718	传动连杆	Connecting Link	1
8	10009721	连杆衬套	Connecting Bush	1
9	10003027	螺母	Nut	1
10	10009715	连杆销	Link Pin	1
11	10012318	垫圈	Washer	1
12	10009467	螺母	Nut	1
13	10009719	切刀曲柄	Cutter Shaft	1
14	10012485	螺钉(M5×9.8)	Screw(M5×9.8)	1
15	10009717	安装座	Holder	1
16	10012073	螺钉(M5×16)	Screw(M5×16)	2
17	10012014	螺钉(M5×4)	Screw(M5×4)	2
18	10010183	防油板	Cover	1
19	10014441	螺钉(M4×6)	Screw(M4×6)	1
20	10010666	螺钉(SM11/64"×40)	Screw(SM11/64"×40)	1
21	10006677	定刀安装座组件	The Counter Knife Holder Asm	1
22	10009037	螺钉(M4×12)	Screw(M4×12)	1
23	10009752	定刀	Counter Knife	1
24	10006812	动刀安装座	Round Knife Holder	1
25	10009712	动刀	Round Knife	1
26	10012763	螺钉(M3.5×12)	Screw(M3.5×12)	1
27	10007068	螺钉(M4×10)	Screw(M4×10)	1
28	10009713	导管	Gas Guide	1
29	10010196	螺钉(M3×3)	Screw(M3×3)	2
30	10010929	挡圈	Ring	1
31	10010617	调压簧	Pressure Spring	1
32	10010932	垫圈	Washer	1
33	10009720	切刀轴	Cutter Shaft	1
34	10010182	气管吸座	Gastube Sustion Holder	1
35	10013195	螺钉(M3×8.5)	Screw(M3×8.5)	1
36	10013159	螺钉(M3.5×7.5)	Screw(M3.5×7.5)	1
37	10009755	分料板	Disprat	1
38	10009379	螺钉(M2.5×4.8)	Screw(M2.5×4.8)	2
39	10007681	气管接头	Connecting Peg	1
40	10009753	气管	Gas Guide	1
41	10009716	安装座轴套	Bushing	1
42	10010846	垫圈	Washer	1

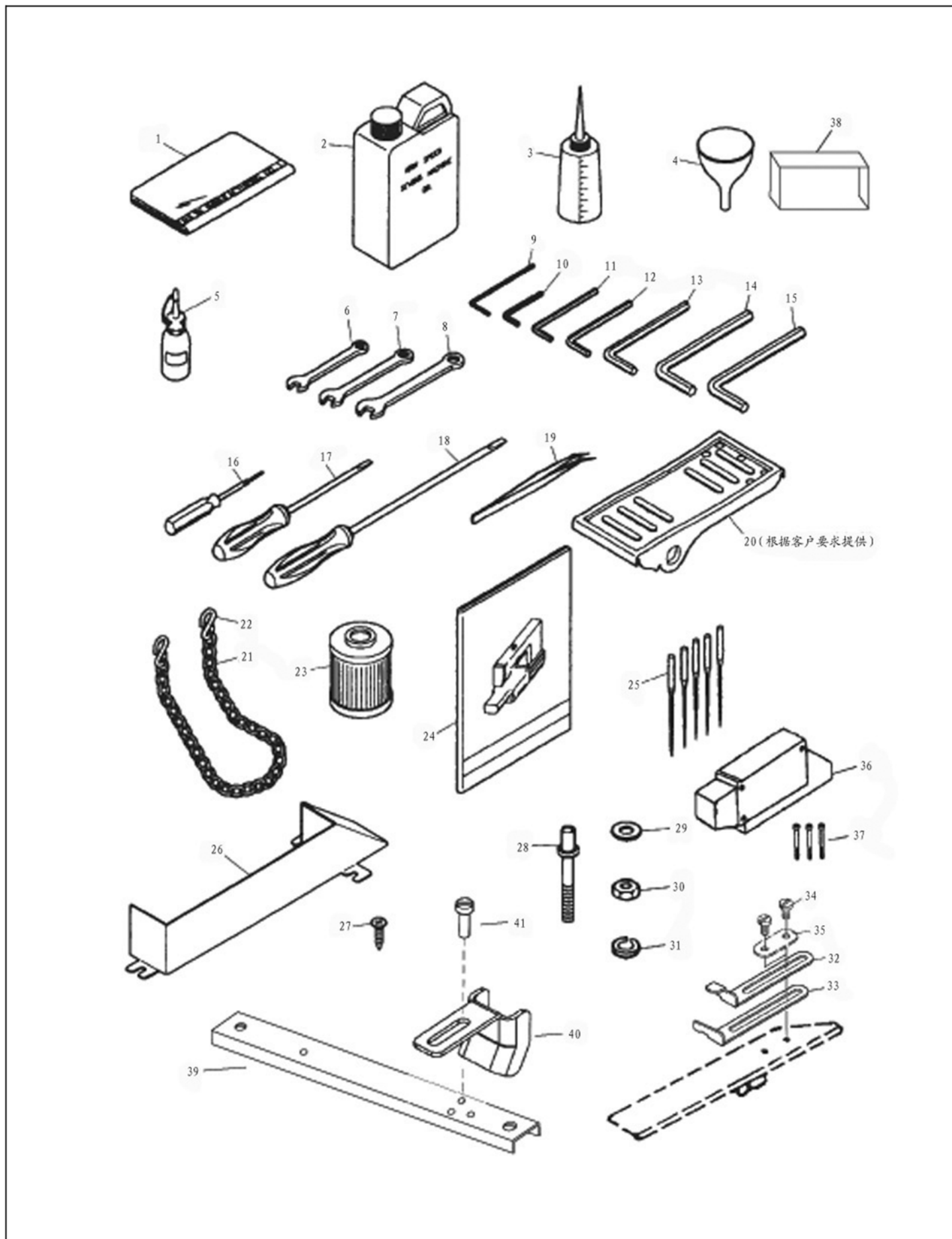

附件盒

ATTACHMENT BOX

序号 No.	件号 Pars No.	名称	Description	数量 Number
1	10011311	机头罩	Machine Cover	1
2	10004882	油壶	Jerrican	1
3	20001784	小油壶组件	Oiler	1
4	10008932	漏斗	Funnel	1
5	10011155	硅油瓶	HP Oiler	1
6	10014185	扳手6#	Spanner (6#)	1
7	10014122	扳手7#	Spanner (7#)	1
8	10014186	扳手8#	Spanner (8#)	1
9	10009684	内六角扳手1.5#	Hexagonal Wrench (1.5#)	1
10	10009683	内六角扳手2#	Hexagonal Wrench (2#)	1
11	10009686	内六角扳手2.5#	Hexagonal Wrench (2.5#)	1
12	10009685	内六角扳手3#	Hexagonal Wrench (3#)	1
13	10009687	内六角扳手4#	Hexagonal Wrench (4#)	1
14	10009689	内六角扳手5#	Hexagonal Wrench (5#)	1
15	10009688	内六角扳手6#	Hexagonal Wrench (6#)	1
16	10009270	内六角开刀	Hexagonal Screwdriver	1
17	10014159	平口开刀110	Screwdriver	1
18	10013982	平口开刀220	Screwdriver	1
19	10004247	镊子组件	Thread Tweezers	1
20	10014375	踏板组件	Pedal C. Set	1
21	10011360	踏板链条	Chain	1
22	10014203	链勾	Hook	2
23	10014236	滤油器组件	Oil Filter	1
24	10006138	使用说明书 零件手册	Explain Book	1
25	10004902	机针UY128GBS 11#	Needle (UY128GBS 11#)	10
26	20003667	台板防护罩	Belt Cover	1
27	10008323	螺钉	Screw	7
28	10012704	螺钉 (M6×57)	Screw (M6×57)	4
29	10012701	垫圈	Washer	8
30	10003077	垫圈	Washer	4
31	10002994	螺母	Nut	4
32	10012838	导布板1	Plate 1	1
33	10012840	导布板2	Plate 2	1
34	10012807	导布板压板	Plate	1
35	10009104	螺钉 (M4×9.5)	Screw (M4×9.5)	2
36	10012310	皮带罩	Beef Cover	1
37	10012685	螺钉 (M4×47)	Screw (M4×47)	3
38	10004956	五线线架部件	Thread Stand	1
39	20003666	固定板	Instead Plate	2
40	10011309	挡链板	Prevent Chain Plate	1
41	10012028	螺钉 (M5×8)	Screw (M5×8)	2

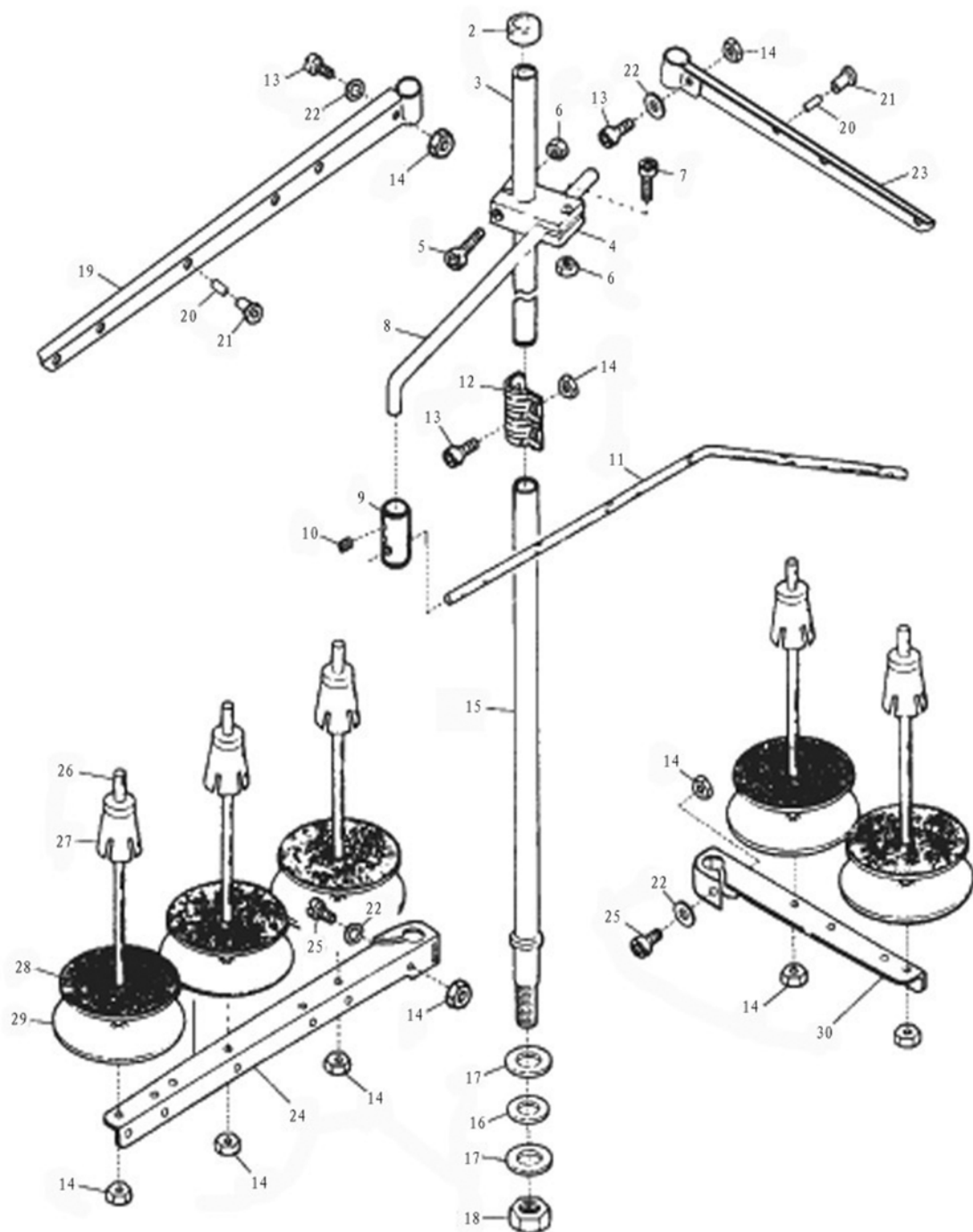

## 线架

## THREAD STAND

序号 No.	件号 Pars No.	名称	Description	数量 Number
1	10004956	五线线架部件	Thread Stand	
2	10004282	线架上撑管套	Column Cop	1
3	10004293	线架上撑管	Column Pipe	1
4	10004335	保持架	Thread Guide Holder	1
5	10002937	螺钉 (M4×25)	Screw (M4×25)	1
6	10005297	螺母	Nut	2
7	10002958	螺钉 (M4×12)	Screw (M4×12)	1
8	10004346	过线杆支杆	Thread Guide Arm	1
9	10004334	过线杆支柱	Thread Guide Holder	1
10	10002851	螺钉 (M6×5)	Screw (M6×5)	2
11	10006076	过线杆	Thread Guide	1
12	10004286	撑管夹	Column Pipe Connector	1
13	10003301	螺钉 (M5×14)	Screw (M5×14)	4
14	10002953	螺母	Nut	11
15	10004291	线架下撑管	Column Pipe	1
16	10004295	垫圈	Washer	1
17	10004290	垫圈	Washer	2
18	10002985	螺母	Nut	1
19	10006345	上过线架	Thread Hanger	1
20	10004289	过线管	Thread Guide Pipe	5
21	10004285	过线管套	Thread Guide Bushing	5
22	10003022	垫圈	Washer	4
23	10004298	上过线架	Thread Hanger	1
24	10006351	下过线架	Thread Hanger	1
25	10003312	螺钉 (M5×30)	Screw (M5×30)	2
26	10004288	线轴	Spool Pin	5
27	10004287	线盘塑料压块	Spool Cushion	5
28	10004281	线盘软垫	Spool Mat	5
29	10004299	线盘	Spool Seat Disc	5
30	10004284	下过线架	Thread Hanger	1

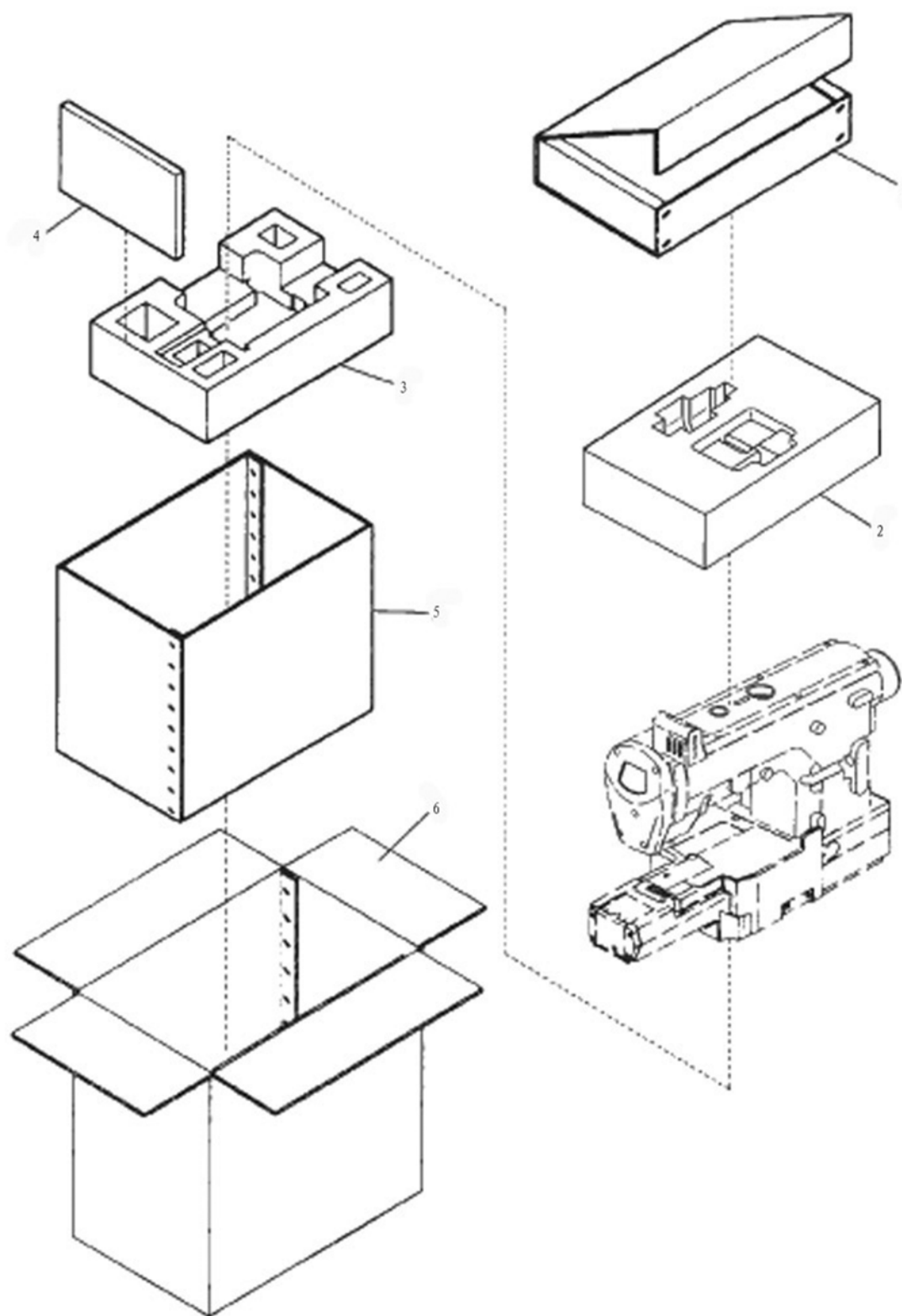







ZOJE

中捷

中国·中捷缝纫机股份有限公司  
ZOJE SEWING MACHINE CO.,LTD.

地址：浙江玉环大麦屿开发区  
ADD: DAMAYU ZONE, YUHUAN, ZHEJIANG, 317604 CHINA  
免费咨询电话: TEL: 800-667-6715

