

高速带刀平缝机 零件手册

ZJ5300

HIGH SPEED LOCKSTITCH WITH VERTICAL EDGE TRIMMER



一. 机壳部件 Arm Bed Components

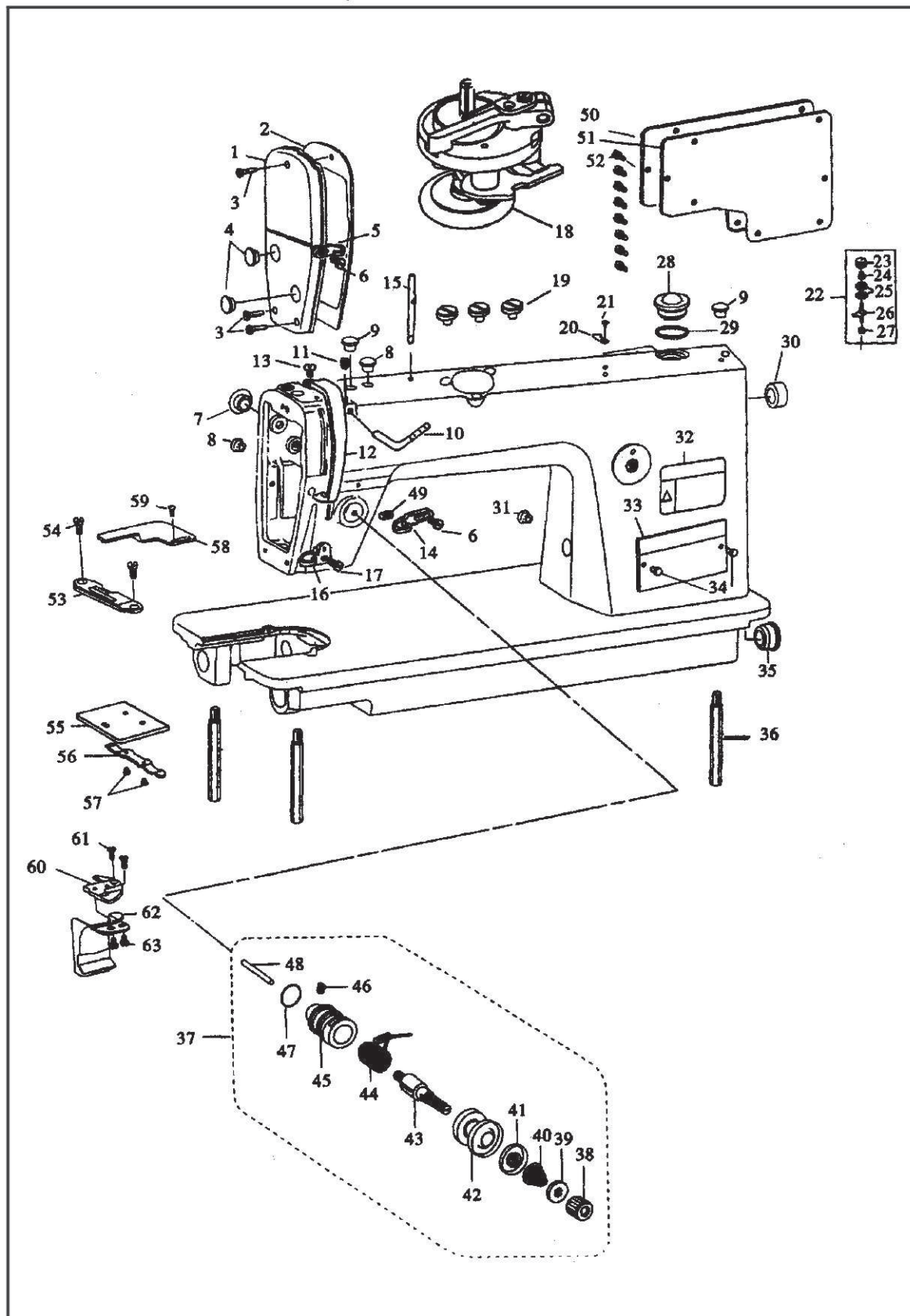

序号 No.	图号 Part number	名称 Name	数量 Qt.	备注 Remark
1	20-01-001	面板Face plate	1	
2	20-01-002	面板垫Gasket	1	
3	20-01-003	面板螺钉Screw	3	
4	20-01-004	面板橡皮塞Rubber plug	2	
5	20-01-005	面板线勾Thread guid on plate	1	
6	20-01-006	线钩螺钉Screw	2	
7	20-01-007	针杆曲柄螺孔塞hole plug	1	
8	20-01-008	膝控提升杠杆(左)螺孔塞hole plug	2	
9	20-01-009	上轴油孔塞Rubber plug	2	
10	20-01-010	三眼线钩Thread-hole guid	1	
11	20-01-011	三眼线钩螺钉Screw	1	
12	20-01-012	挑线杆防护罩Thread take-up lever cover	1	
13	20-01-013	挑线杆防护罩螺钉Screw	1	
14	20-01-014	右线钩Frame thread guid right	1	
15	20-01-015	过线柱Needle thread guid pin		
16	20-01-016	下线钩Frame thread guid lower	1	
17	20-01-017	下线钩螺钉Screw	1	
18	20-01-018	绕线器Bobbin winder base components	1	
19	20-01-019	绕线器安装螺钉Screw	3	
20	20-01-020	切线刀Knife	1	
21	20-01-021	塑料夹线螺母Nuts	1	
22	20-01-022	中过线板组件Middle thread guid plate asm.	1	
23	20-01-023	夹线螺母Thread tension nut	1	
24	20-01-024	夹线簧Thread tension spring	1	
25	20-01-025	小夹线板Disc for pre-tension	1	
26	20-01-026	切线刀螺钉Screw	1	
27	20-01-027	绕线夹线器垫圈Thread tension asm.	1	
28	20-01-028	油窗Oil sight window	1	
29	20-01-029	针距调节器孔塞Rubber plug	1	
30	20-01-030	竖轴下套右孔塞Rubber plug	1	
31	20-01-031	橡皮塞Rubber plug	1	
32	20-01-032	警示牌Warning plate	1	
33	20-01-033	型号牌Model plate	2	
34	20-01-034	铆钉Screw	1	
35	20-01-035	下轴盲孔塞Rubber plug	3	
36	20-01-036	底板撑杆Arm bed assy	1	
37	20-01-037	夹线器组件Thread tension asm.	1	
38	20-01-038	夹线螺母Thread tension nut	1	
39	20-01-039	夹线螺母止动板Tread disc rotation stopper	1	
40	20-01-040	夹线弹簧Thread tension spring	1	
41	20-01-041	松线板Tension release disc	2	
42	20-01-042	夹线板Thread tension disc	1	
43	20-01-043	夹线螺钉Screw	1	
44	20-01-044	挑线簧Take-up spring	1	
45	20-01-045	夹线调节座Thread tension post socket	1	
46	20-01-046	夹线调节座螺钉Screw	1	
47	20-01-047	O型圈O ring	1	
48	20-01-048	松线钉Tension release pin	1	
49	20-01-049	夹线器固定螺钉Screw	1	
50	20-01-050	后盖板Side plate	1	
51	20-01-051	后盖板垫Gasket	8	
52	20-01-052	后盖板螺钉组件Screw asm.	1	
53	20-01-053	针板Threat plate	2	
54	20-01-054	针板螺钉Screw	1	
55	20-01-055	推板Slide plate	1	
56	20-01-056	推板簧Slide plate spring	2	
57	20-01-057	推板簧螺钉Screw	1	
58	20-01-058	布屑导板Chip funnelcover	2	
59	20-01-059	布屑导板螺钉Screw	1	
60	20-01-060	排屑斗板Chip funnel plate	1	
61	20-01-061	排屑斗板螺钉Screw	1	
62	20-01-062	排屑斗Chip funnel	2	
63	20-01-063	排屑斗螺钉Screw	2	

二. 上轴针杆挑线部件 Arm Shaft , Vertical Shaft And Thread Take -up Mechanism

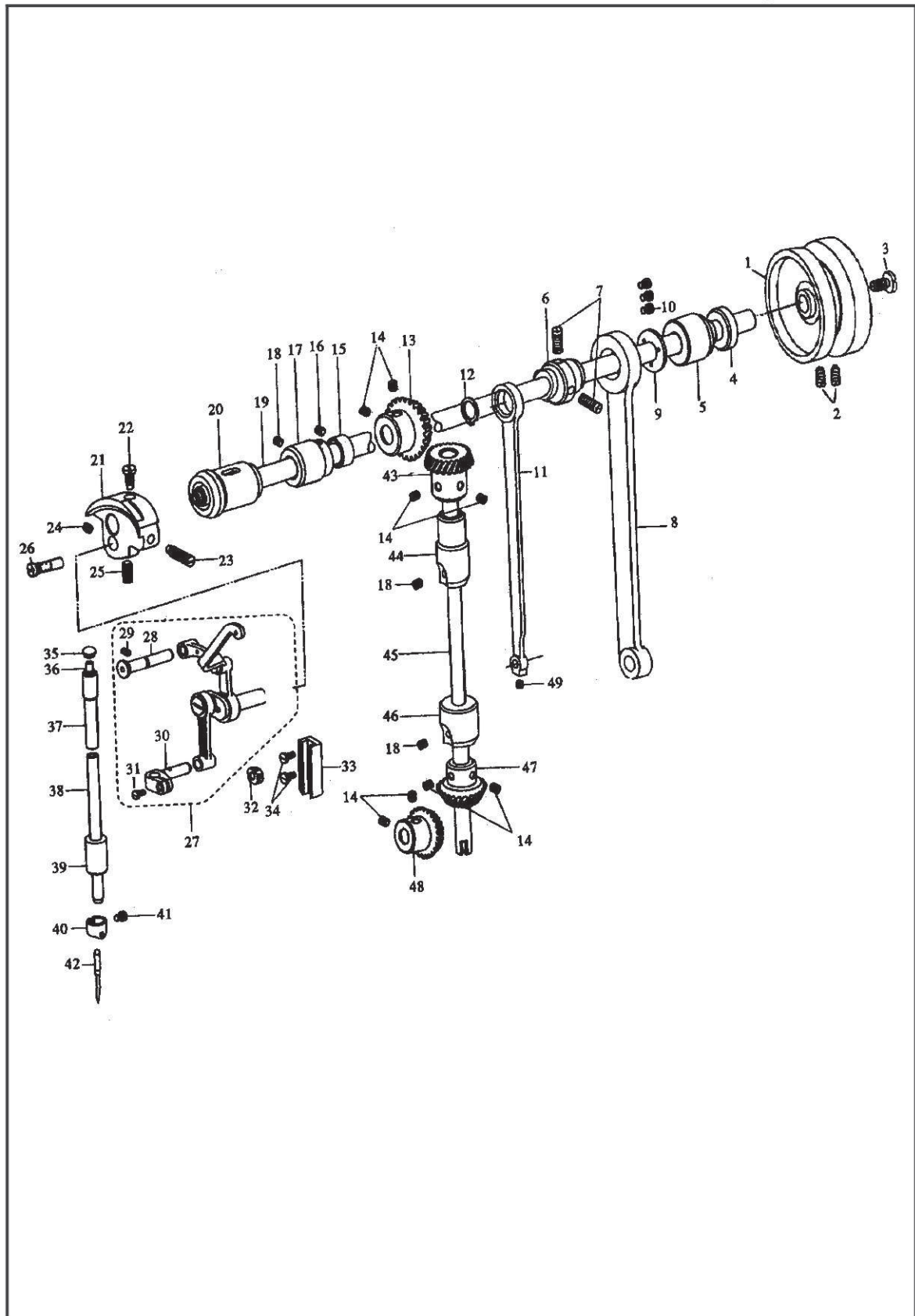

序号 No.	图号 Part number	名称 Name	数量 Qt.	备注 Remark
1	20-02-001	主动轮Balance wheel	1	
2	20-02-002	主动轮螺钉Set screw	1	
3	20-02-003	上轴轴端螺钉Screw	3	
4	20-02-004	上轴轴套(右)油封Oil seal	2	
5	20-02-005	上轴轴套(右) Arm shaft bushing(right)	1	
6	20-02-006	送料凸轮Feed and feed lifting eccentric	2	
7	20-02-007	送料凸轮螺钉Screw	1	
8	20-02-008	抬牙连杆Connecting rod for feeding	2	
9	20-02-009	送料凸轮挡片Washer	2	
10	20-02-010	送料凸轮挡片螺钉Screw	1	
11	20-02-011	送料连杆Connecting rod for feed lifting	1	
12	20-02-012	送料凸轮挡圈Retaining ring	1	
13	20-02-013	上轴伞齿轮Bevel gear for arm shaft	1	
14	20-02-014	伞齿轮螺钉Screw	1	
15	20-02-015	上轴紧圈Collar for arm shaft		
16	20-02-016	上轴紧圈螺钉Screw	1	
17	20-02-017	上轴轴套(中) Arm shaft bushing(middle)	1	
18	20-02-018	上轴轴套(中)螺钉Screw	1	
19	20-02-019	上轴Arm shaft	3	
20	20-02-020	上轴轴套(左) Arm shaft bushing(left)	1	
21	20-02-021	针杆曲柄Crank	1	
22	20-02-022	针杆曲柄定位螺钉Screw	1	
23	20-02-023	针杆曲柄螺钉Screw	1	
24	20-02-024	挑线曲柄螺钉Screw	1	
25	20-02-025	挑线曲柄螺钉Screw	1	
26	20-02-026	曲柄油量调节销Oil amount adjusting pin	1	
27	20-02-027	针杆连杆挑线杆大组件Thread take-up asm	1	
28	20-02-028	挑线杆铰链轴Hinge pin	1	
29	20-02-029	挑线杆铰链轴螺钉Screw	1	
30	20-02-030	针杆接头Needle bar link	1	
31	20-02-031	针杆接头螺钉Screw	1	
32	20-02-032	针杆接头滑块Need bar guide slide block	1	
33	20-02-033	针杆接头滑块导轨Guide for slide block	2	
34	20-02-034	滑块导轨螺钉Screw	1	
35	20-02-035	针杆上轴套橡皮塞Rubber plug	3	
36	20-02-036	针杆轴套(上)毛毡Felt plug	1	
37	20-02-037	针杆轴套(上) Needle bar bushing(upper)	1	
38	20-02-038	针杆Needle bar	1	
39	20-02-039	针杆轴套(下) Needle bar bushing(lower)	1	
40	20-02-040	针杆过线环bushing	1	
41	20-02-041	夹针螺钉Screw	2	
42	20-02-042	机针Needle	1	
43	20-02-043	竖轴伞齿轮(上) Bevel gear	1	
44	20-02-044	竖轴轴套(上) Vertical shaft bushing	1	
45	20-02-045	竖轴Vertical shaft	1	
46	20-02-046	竖轴轴套(下)Vertical shaft bushing	1	
47	20-02-047	竖轴伞齿轮(下) Bevel gear	1	
48	20-02-048	下轴伞齿轮bevel gear assy	1	
49	20-02-049	曲柄连杆螺钉Screw	1	

三. 拾牙送料部件 Needle Bar And Thread Tension Components

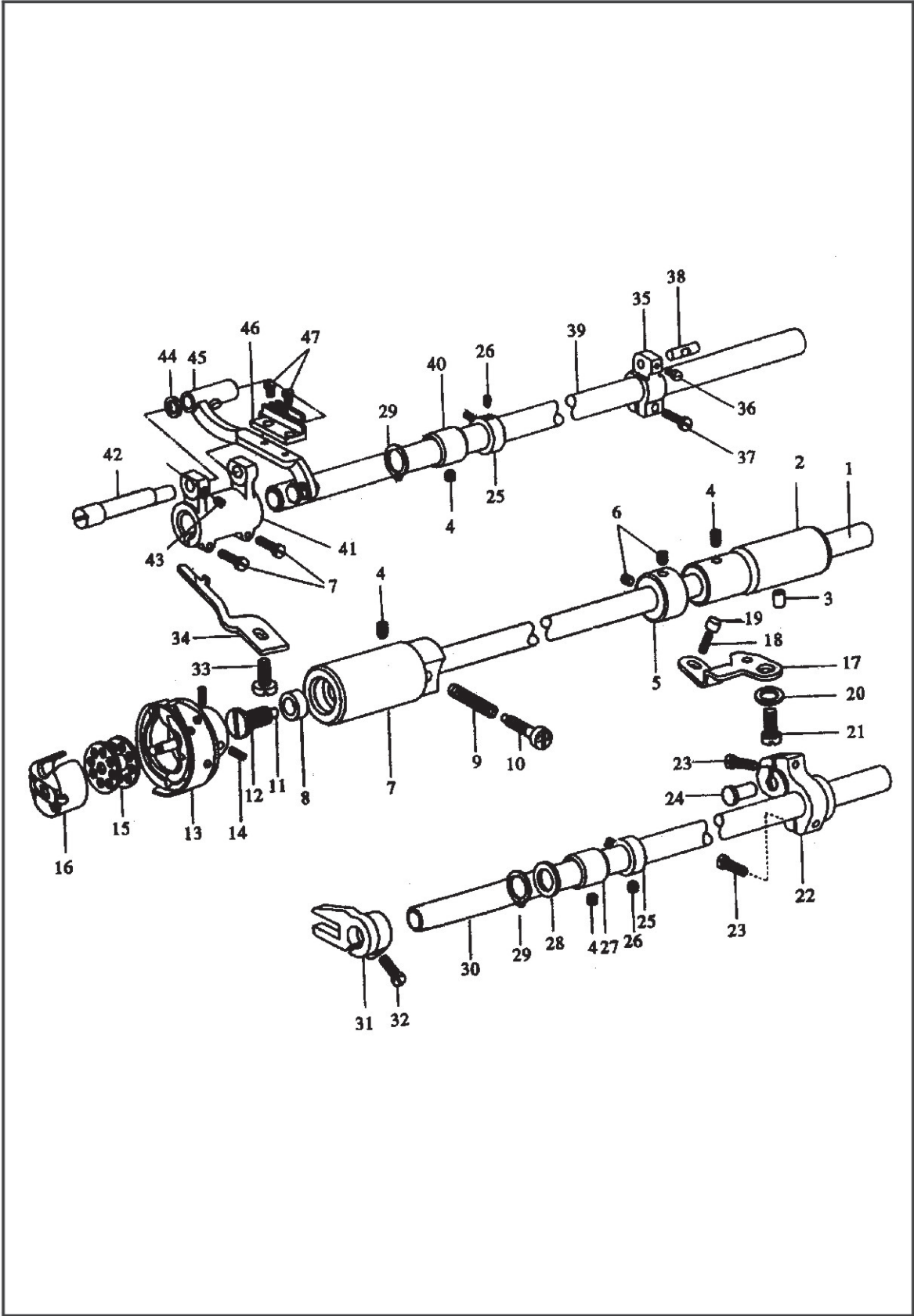

序号 No.	图号 Part number	名称 Name	数量 Qt.	备注 Remark
1	20-03-001	下轴 Hook shaft	1	
2	20-03-002	下轴轴套(右) bushing	1	
3	20-03-003	下轴轴套(右)油管接头 Oil pipe	3	
4	20-03-004	抬牙轴套螺钉 Set screw	2	
5	20-03-005	下轴紧圈 Collar for hook shaft	1	
6	20-03-006	下轴紧圈螺钉 Set screw	2	
7	20-03-007	下轴轴套(左) bushing(left)	1	
8	20-03-008	下轴油封 Oil seal	2	
9	20-03-009	油量调节弹簧 Spring	2	
10	20-03-010	油量调节螺钉 Oil adjusting screw	1	
11	20-03-011	下轴滤油塞 Filter	1	
12	20-03-012	下轴滤油塞螺钉 Filter screw	1	
13	20-03-013	旋梭组件 Rotating hook complete	1	
14	20-03-014	旋梭螺钉 Screw	1	
15	20-03-015	梭芯 Bobbin		
16	20-03-016	梭芯套组件 Bobbin case	1	
17	20-03-017	柱塞挡板 Guide plate	1	
18	20-03-018	柱塞弹簧 Plunger spring	1	
19	20-03-019	柱塞 Plunger	3	
20	20-03-020	挡板螺钉弹簧垫片 Washer	1	
21	20-03-021	挡板螺钉 Screw	1	
22	20-03-022	抬牙轴曲柄(右) crank(right)	1	
23	20-03-023	抬牙轴曲柄(右)螺钉 Screw	1	
24	20-03-024	抬牙轴曲柄铰链轴 Hinge shaft	1	
25	20-03-025	抬牙轴紧圈 Collar	1	
26	20-03-026	抬牙轴紧圈螺钉 Screw	1	
27	20-03-027	抬牙轴轴套 Bushing	1	
28	20-03-028	抬牙轴垫片 Washer	1	
29	20-03-029	轴用弹性卡圈 C-type stop ring	1	
30	20-03-030	抬牙轴 shaft	1	
31	20-03-031	抬牙叉 Feed lifting rock crank	1	
32	20-03-032	抬牙叉螺钉 Screw	1	
33	20-03-033	旋梭定位钩螺钉 Screw	2	
34	20-03-034	旋梭定位钩 positioner	1	
35	20-03-035	送布轴曲柄(右) crank(right)	3	
36	20-03-036	曲柄连杆短销螺钉 Set screw	1	
37	20-03-037	送布轴曲柄(右)螺钉 Screw	1	
38	20-03-038	曲柄连杆短销 Short pin	1	
39	20-03-039	送料轴 Feed rock shaft	1	
40	20-03-040	送料轴轴套 Bushing	1	
41	20-03-041	牙架曲柄 Crank for feed bar	2	
42	20-03-042	牙架曲柄偏心轴 Eccentric shaft	1	
43	20-03-043	牙架曲柄偏心轴螺钉 Screw	1	
44	20-03-044	牙架垫圈 Washer	1	
45	20-03-045	牙架组件 Feed bar	1	
46	20-03-046	送料牙 Feed dog	1	
47	20-03-047	送料牙螺钉 Screw	1	

四. 针距调节部件 Stitch Length Regulating Mechanism

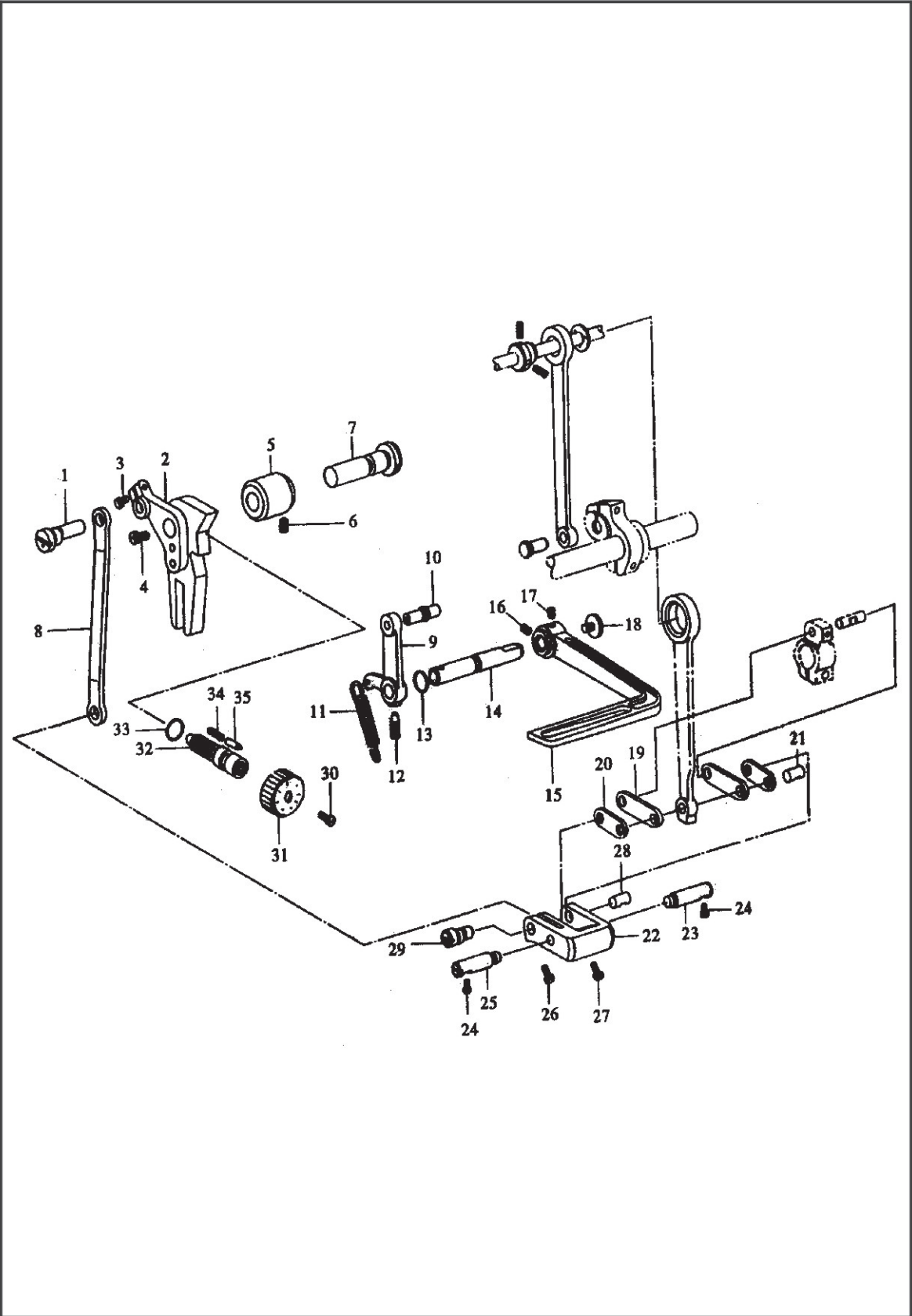

序号 No.	图号 Part number	名称 Name	数量 Qt.	备注 Remark
1	20-04-001	针距调节连杆销钉 Connecting stud	1	
2	20-04-002	针距调节摆杆 Feed regulator	1	
3	20-04-003	连杆销钉夹紧螺钉 Screw	1	
4	20-04-004	针距调节摆杆螺钉 Screw	1	
5	20-04-005	针距调节摆杆轴套 bushing	1	
6	20-04-006	针距调节摆杆轴套螺钉 screw	1	
7	20-04-007	针距调节摆杆铰链轴 Hinge pin	1	
8	20-04-008	针距连杆 Feed regulator rod	1	
9	20-04-009	倒缝操纵杆曲柄 Crank	1	
10	20-04-010	倒缝操纵杆滚柱组件 stud	1	
11	20-04-011	倒缝操纵杆曲柄拉簧 Spring	1	
12	20-04-012	倒缝操纵杆曲柄螺钉 Screw	1	
13	20-04-013	倒缝操纵杆短轴O型圈 O ring	1	
14	20-04-014	倒缝操纵杆短轴 Short shaft	1	
15	20-04-015	倒缝操纵杆 Reverse stitching lever	1	
16	20-04-016	倒缝操纵杆支头螺钉 Screw	1	
17	20-04-017	倒缝操纵杆定位螺钉 Screw	1	
18	20-04-018	倒缝操纵杆吊紧螺钉 Screw	1	
19	20-04-019	曲柄长连杆 Feed tock arm link	2	
20	20-04-020	曲柄短连杆 Feed tock link	2	
21	20-04-021	曲柄连杆短销 Pin	1	
22	20-04-022	针距调节曲柄 Level regulator	1	
23	20-04-023	针距调节曲柄定位销(右) pin(R)	1	
24	20-04-024	定位销螺钉 Screw	2	
25	20-04-025	针距调节曲柄定位销(左) pin(L)	1	
26	20-04-026	连杆轴螺钉 Screw	1	
27	20-04-027	曲柄连杆螺钉 Screw	1	
28	20-04-028	曲柄短连杆销 Feed link stud	1	
29	20-04-029	连杆偏心轴 shaft	1	
30	20-04-030	标盘螺钉 Screw	1	
31	20-04-031	针距标盘 Stitch length dial	1	
32	20-04-032	针距调节螺杆 Adjust screw	1	
33	20-04-033	针距调节螺杆O型圈 O ring	1	
34	20-04-034	止动销弹簧 Spring	1	
35	20-04-035	止动销 Positioning pin	1	

五. 压脚部件 Presser Foot Parts

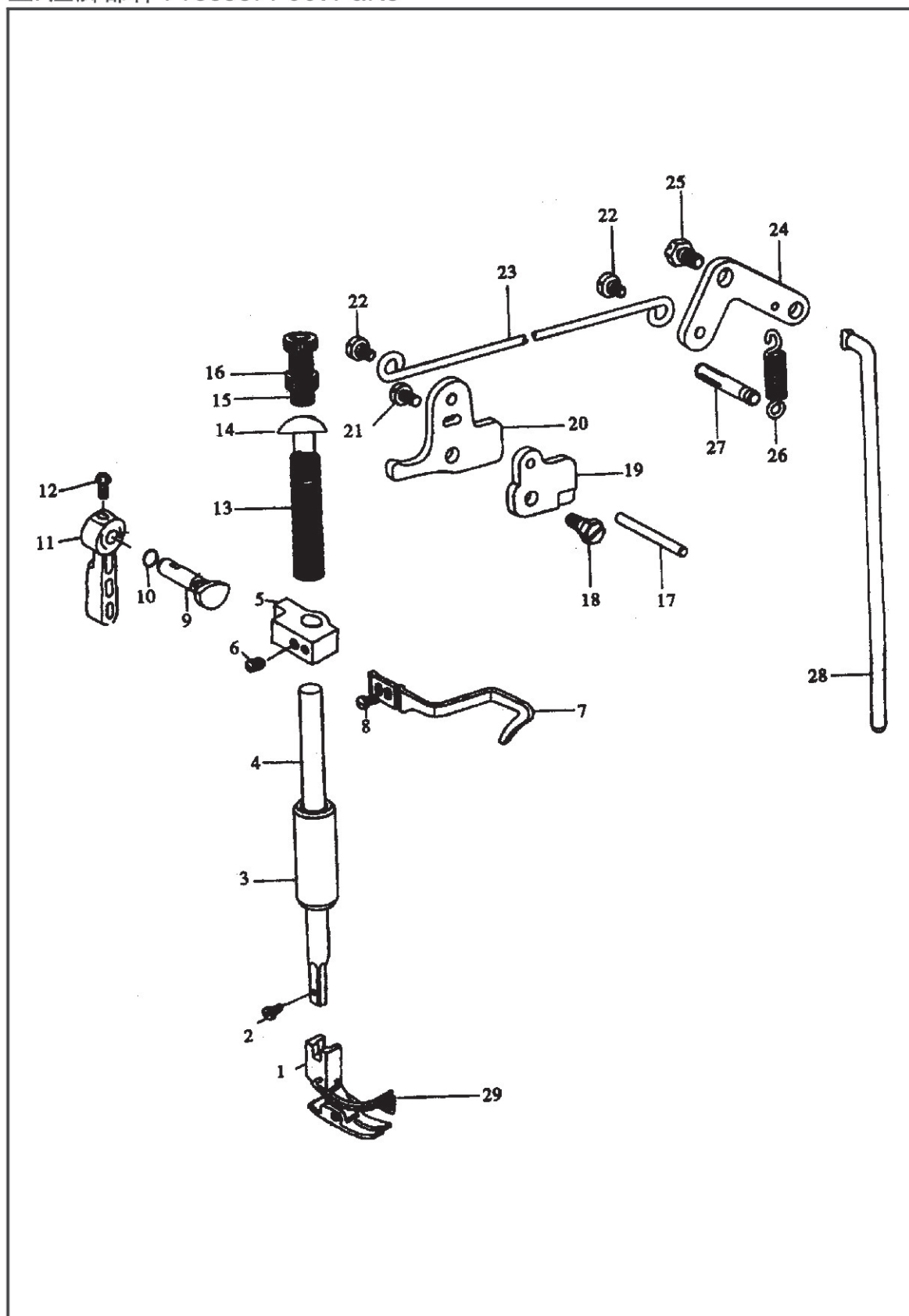

序号 No.	图号 Part number	名称 Name	数量 Qt.	备注 Remark
1	20-05-001	压脚组件 Presser foot assy	1	
2	20-05-002	压脚螺钉 Screw	1	
3	20-05-003	压紧杆轴套 Presser bar bush	1	
4	20-05-004	压紧杆 Presser bar	1	
5	20-05-005	压紧杆导架 guide bracket	1	
6	20-05-006	压紧杆导架螺钉 Screw	1	
7	20-05-007	大线钩 Thread guide	1	
8	20-05-008	大线钩螺钉 Screw	1	
9	20-05-009	压脚提升凸轮 lifter crank	1	
10	20-05-010	压脚提升凸轮O型圈 O ring	1	
11	20-05-011	压脚扳手 Presser bar lifter	1	
12	20-05-012	压脚扳手螺钉 Screw	1	
13	20-05-013	压紧杆弹簧 Spring	1	
14	20-05-014	压紧杆弹簧导柱 Spring guide	1	
15	20-05-015	调压螺钉 Adjust screw	1	
16	20-05-016	调压螺钉锁紧螺母 Nut	1	
17	20-05-017	松线杆 Tension release bar	1	
18	20-05-018	松线凸轮螺钉 Screw	1	
19	20-05-019	松线凸轮 Tension releasing cam	1	
20	20-05-020	膝控提升杠杆(左) lifter(L)	1	
21	20-05-021	膝控提升杠杆(左)螺钉 Screw	1	
22	20-05-022	铰链轴螺钉 Screw	2	
23	20-05-023	膝控提升拉杆 connecting rod	1	
24	20-05-024	膝控提升杠杆(右) lifter(R)	1	
25	20-05-025	膝控提升杠杆(右)螺钉 Screw	1	
26	20-05-026	膝控提升杠杆(右)弹簧 Spring	1	
27	20-05-027	弹簧销 Pin for spring	1	
28	20-05-028	膝控提升连杆 Knee lifter bar	1	

六. 切刀控制部件 Knife Control Mechanism

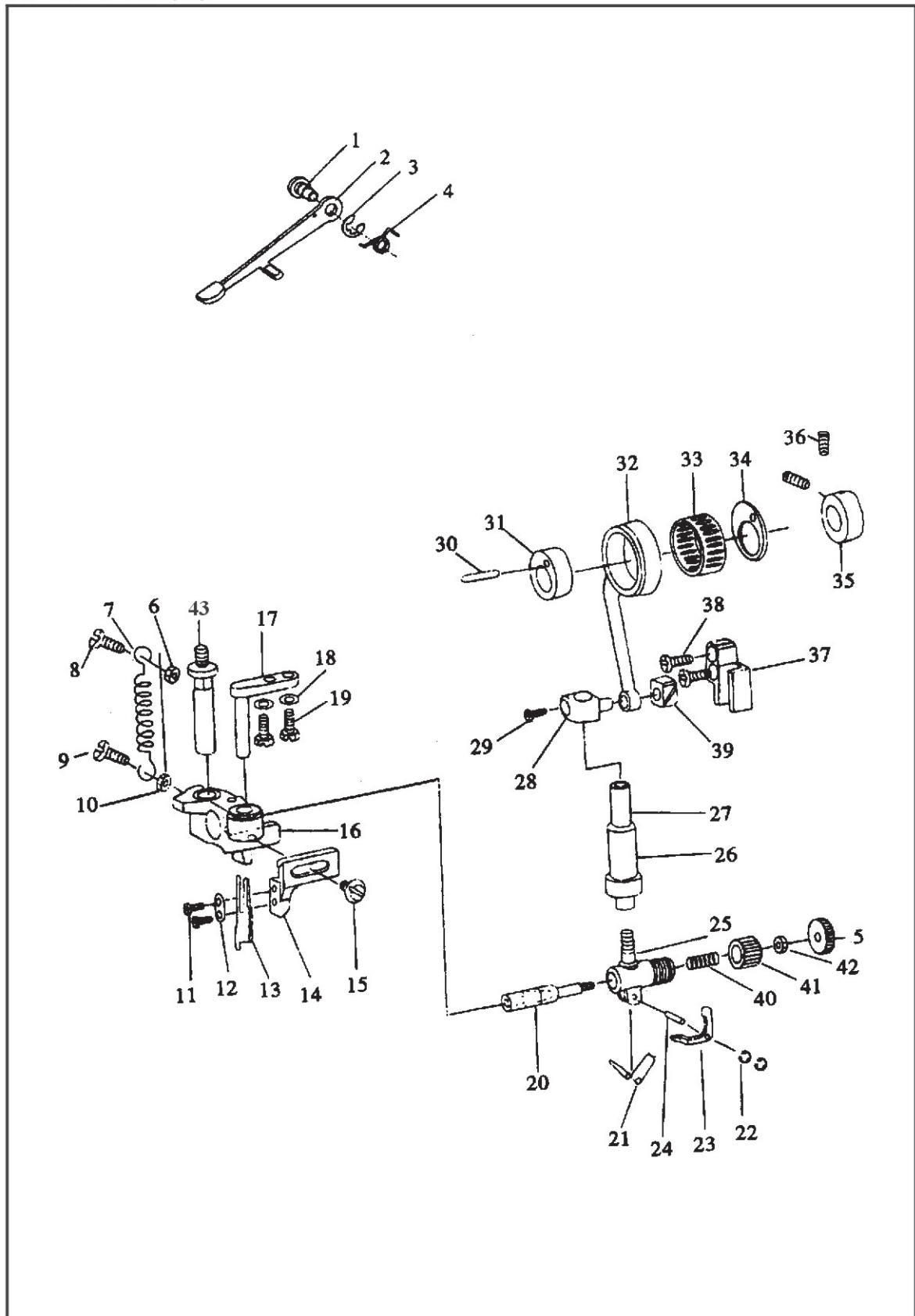

序号 No.	图号 Part number	名称 Name	数量 Qt.	备注 Remark
1	20-06-001	控刀轴位螺钉Screw	1	
2	20-06-002	控刀杆Operating lever for knife	1	
3	20-06-003	E型挡圈E-type ring	1	
4	20-06-004	控刀扳手扭簧Spring	1	
5	20-06-005	控刀拉钮Nut	1	
6	20-06-006	导向架拉簧螺帽(上) Nut(upper)	1	
7	20-06-007	导向架拉簧Spring	1	
8	20-06-008	导向架拉簧螺钉(上) Screw(upper)	1	
9	20-06-009	导向架拉簧螺钉Screw	1	
10	20-06-010	导向架拉簧螺母Nut	1	
11	20-06-011	刀片固定螺钉Set scerw	2	
12	20-06-012	切刀垫片Gasket	1	
13	20-06-013	切刀Cutting knife	1	
14	20-06-014	刀架Knife holder	1	
15	20-06-015	刀架螺钉Screw	1	
16	20-06-016	刀架导向架Guide bracket	1	
17	20-06-017	导向架导轨Guiding block	1	
18	20-06-018	固定螺钉垫圈Washer	2	
19	20-06-019	导向架导轨固定螺钉Set scerw	2	
20	20-06-020	导向架控制销Pin	1	
21	20-06-021	杠杆簧Spring	1	
22	20-06-022	E型挡圈E-type ring	2	
23	20-06-023	切刀控制杠杆Lever for knife	1	
24	20-06-024	杠杆连接销Pin	1	
25	20-06-025	控制销导套Guiding bushing	1	
26	20-06-026	刀杆轴套Bushing for knife bar	1	
27	20-06-027	刀杆Knife bar	1	
28	20-06-028	刀杆接头Knife bar adaptor	1	
29	20-06-029	刀杆接头螺钉Screw	1	
30	20-06-030	连接销Pin	1	
31	20-06-031	刀杆凸轮Eccentric cam	1	
32	20-06-032	刀杆连杆Connecting rod	1	
33	20-06-033	滚针轴承Needle bearing	1	
34	20-06-034	凸轮垫片Thrust plate	1	
35	20-06-035	绕线器主动轮Bobbin wheel	1	
36	20-06-036	绕线器主动轮螺钉Screw	2	
37	20-06-037	刀杆接头滑块导轨Guide rail	1	
38	20-06-038	刀杆接头滑块螺钉Set scerw	1	
39	20-06-039	刀杆接头滑块Slide block	1	
40	20-06-040	刀控弹簧Spring	1	
41	20-06-041	导套盖Cap	1	
42	20-06-042	导柱螺母Nut	1	
43	20-06-043	导向架导柱Guide plunger	1	

七. 润滑部件 Lubrication Mechanism

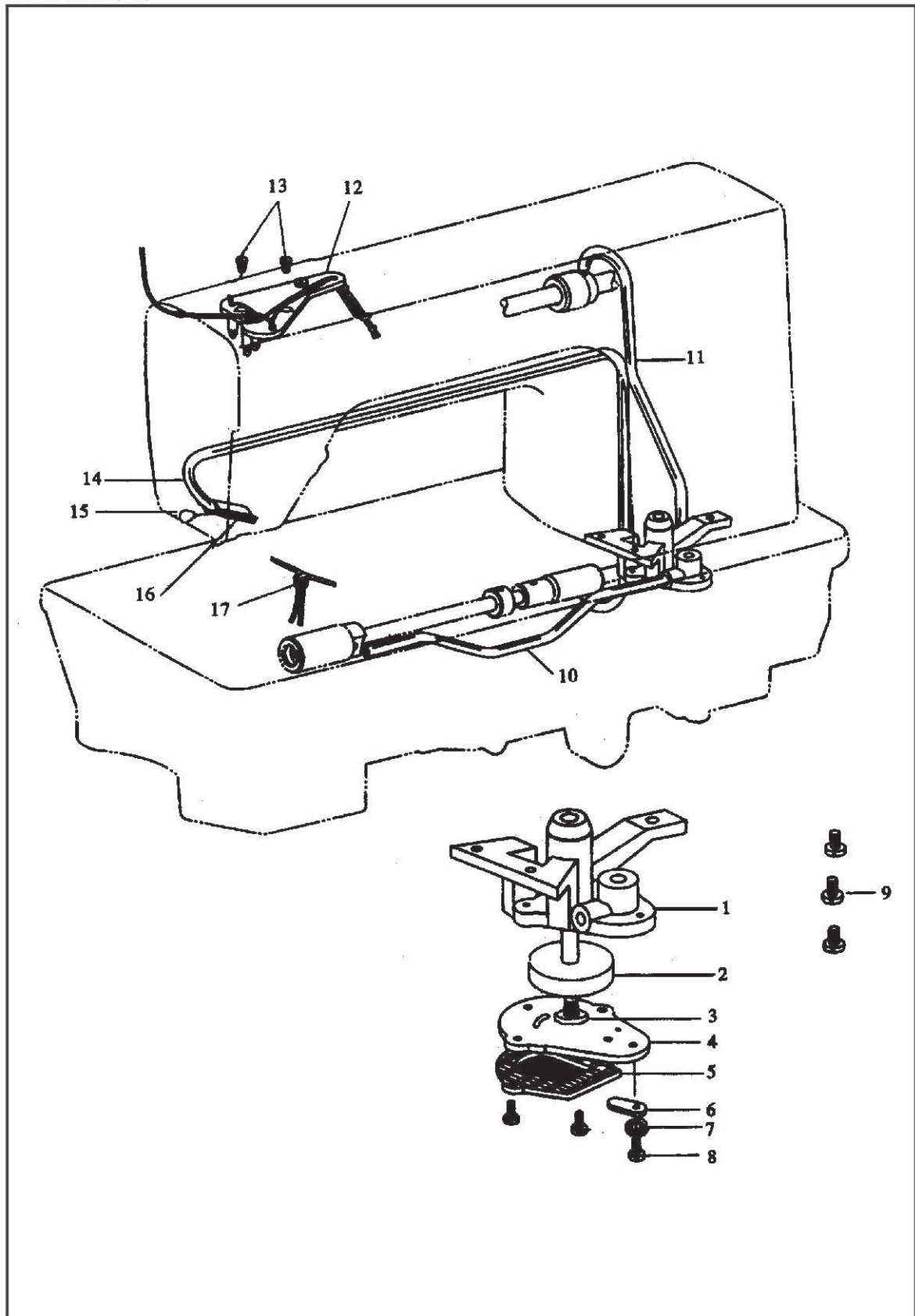

序号 No.	图号 Part number	名称 Name	数量 Qt.	备注 Remark
1	20-07-001	油泵体 Oil pump body	1	
2	20-07-002	油泵体叶轮 Oil pump propeller	1	
3	20-07-003	叶轮螺钉 Screw	1	
4	20-07-004	油泵体盖板 Oil pump fitting plate	1	
5	20-07-005	油泵滤油网 Oil pump screen assy	1	
6	20-07-006	油量调节板 Oil adjusting plate	1	
7	20-07-007	油量调节板螺钉弹性垫圈 washer	3	
8	20-07-008	油泵体盖板螺钉 Screw	3	
9	20-07-009	油泵体螺钉 Screw	3	
10	20-07-010	下轴油管组件 Oil pipe	1	
11	20-07-011	上轴油管组件 Oil pipe	1	
12	20-07-012	油线固定板大组件 Oil braid	1	
13	20-07-013	油线固定板螺钉 Screw	2	
14	20-07-014	回油管 Oil return pipe	1	
15	20-07-015	回油管毡夹 Pipe holder	1	
16	20-07-016	回油管油毡 Felt pouch	1	
17	20-07-017	油线 Wick	1	

八. 油盘 附件 Oil Reservoir & knee Lifter Components

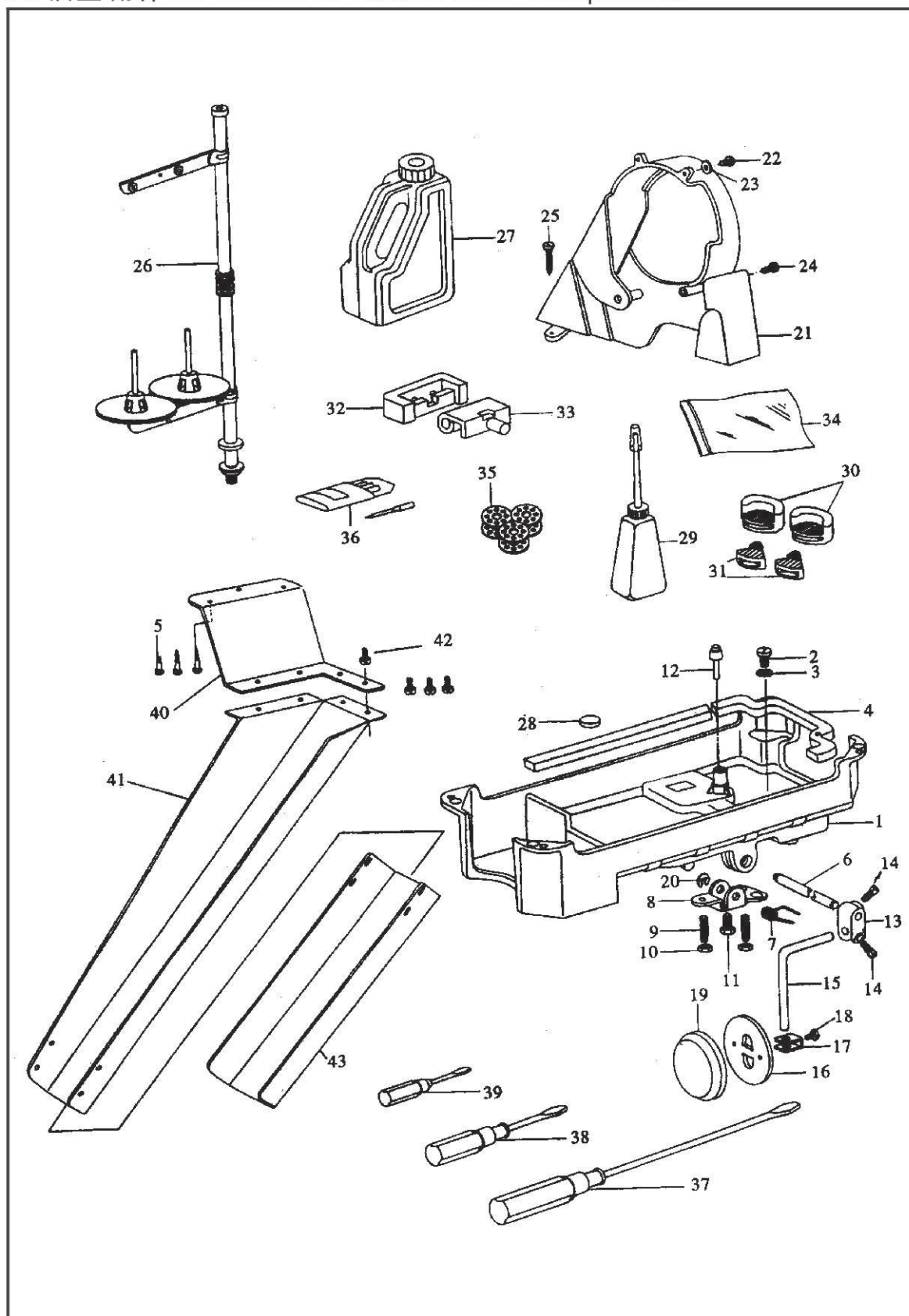

序号 No.	图号 Part number	名称 Name	数量 Qt.	备注 Remark
1	20-08-001	油盘 Oil reservoir asm.	1	
2	20-08-002	放油螺钉 Oil drain screw	1	
3	20-08-003	放油螺钉垫圈 Oil drain cap gasket	1	
4	20-08-004	油盘垫 Paxking	1	
5	20-08-005	导屑滑板支架木螺钉 Wood screw	1	
6	20-08-006	膝控铰链轴 Knee press rod	1	
7	20-08-007	膝控复位弹簧 spring	1	
8	20-08-008	膝控限位架 Lifting	1	
9	20-08-008	膝控限位调节螺钉 Positioning screw	2	
10	20-08-010	调节螺母 Nut	2	
11	20-08-011	膝控限位架螺钉 Lifting screw	1	
12	20-08-012	膝控提升顶杆 Knee press lifter rod asm	1	
13	20-08-013	碰块弯杆接头 Bearing bracket	1	
14	20-08-014	碰块弯杆接头螺钉 lamp screw	2	
15	20-08-015	膝控碰块弯杆 Knee lifter plate rod	1	
16	20-08-016	膝控碰块 Knee lifter plate	1	
17	20-08-017	碰块架 Knee lifter plate cover joint	1	
18	20-08-018	碰块架螺钉 Screw	1	
19	20-08-018	碰块垫 Knee lifter plate cover	1	
20	20-08-020	开口挡圈 Thrust ring	1	
21	20-08-021	皮带罩组件 Belt cover	1	
22	20-08-022	皮带罩螺钉(小) Screw	2	
23	20-08-023	皮带罩螺钉垫圈 Washre	2	
24	20-08-024	皮带罩螺钉(大) Screw	2	
25	20-08-025	木螺钉 Wood screw	2	
26	20-08-026	线架组件 Duple-thread spool stand asm.	1	
27	20-08-027	油箱 Lubricating unit case asm.	1	
28	20-08-028	磁块 Magnet	1	
29	20-08-028	小油壶 Oiler	1	
30	20-08-030	机头防震垫块(大) Oil reservoir rubber cushion	2	
31	20-08-031	机头防震垫块(小) Oil reservoir felt cushion	2	
32	20-08-032	机头台板连接钩 Rubbre cushion	2	
33	20-08-033	连接钩防震外护套 Heed hingr	2	
34	20-08-034	零件袋 Accessort bag	1	
35	20-08-035	梭芯 Bobbin	4	
36	20-08-036	机针 Needle	1	
37	20-08-037	螺钉起子(大) Screw driver(L)	1	
38	20-08-038	螺钉起子(中) Screw driver(M)	1	
39	20-08-038	螺钉起子(小) Screw driver(S)	1	
40	20-08-040	导屑滑板支架 Waste material chute holder	1	
41	20-08-041	导屑滑板 Waste material chute	1	
42	20-08-042	导屑滑板螺钉 Screw	4	
43	20-08-043	导屑连接滑板 Waste material chute joint	1	