

JEMA

多功能电脑切带机 MULTIFUNCTION AUTO-CUTTING MACHINE

使用说明书 INSTRUCTION MANUAL

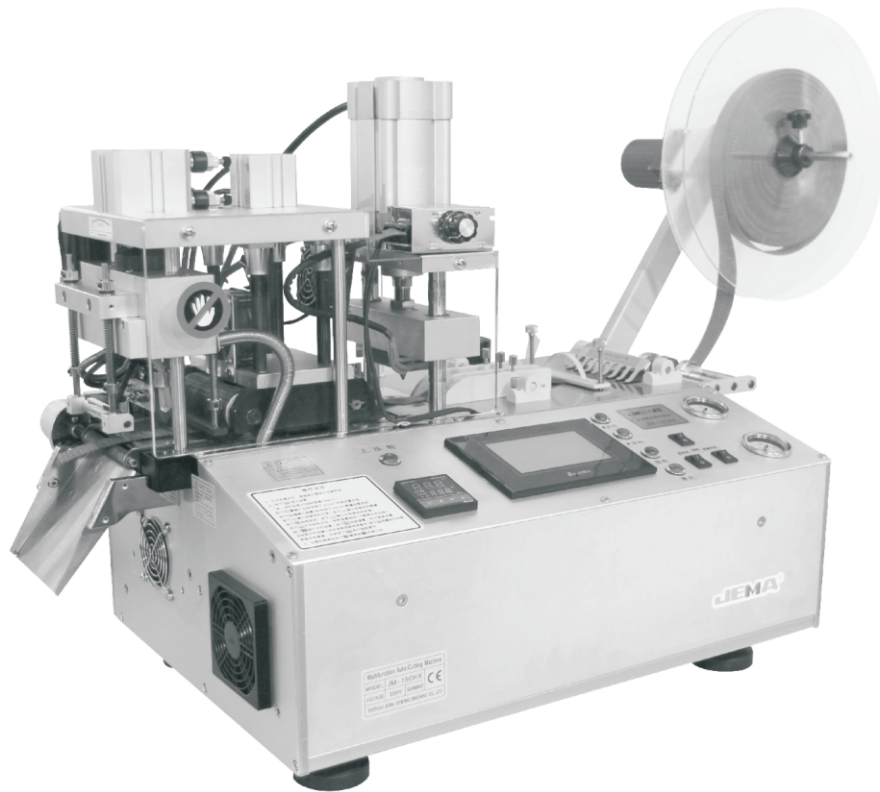

台州市箭马缝纫机有限公司
TAIZHOU JEMA SEWING MACHINE CO.,LTD.

一、简述

多功能电脑切带机是集气、机电一体化的新型专机，它是用输入电脑程序自动控制机械、气缸的动作，可按您所需长度、数量自动切断不同宽度、长度及任意角度的编织带、塑料软管、鞋带、商标等带状物品。根据所切材料的弹性不同而设计的补偿功能，可为您的产品带来更高的精确度。选装件：（红外定位装置：通过红外传感器系统定位精确切断各类不同宽度尺寸的商标。冲孔装置：根据客户需要，更换冲模，冲出大小不同的孔。）。具有无料自动停止功能。切断材料厚、精度高、切断速度快、切断面平整无毛刺、尼龙材料不散丝、操作简单等特点。是您提高生产效率，提高产品质量，节省人工的首选。

二、规格

型号	功率 KW	最大收料 高度 mm	建议气压 Mpa	最大切断宽度 直角/斜角 MM	切断长度 MM	冲孔直径 mm	刀片最高 温度℃	50mm 切断速度/分 /收料	电压 V	包装尺寸 MM
150LR	1.2	40	0.3-0.6	95	20-99999	2 - 8	350	150	110/220	820x570x780
150H	1.2	30	0.3-0.6	95	20-99999	2 - 8	420	150	110/220	820x570x780
150HX	1.05	-	0.3-0.6	65 / 40	20-99999	2 - 8	420	150	110/220	820x570x780
150L	0.3	40	0.3-0.6	95	20-99999	2 - 8	-	150	110/220	820x570x780

注：选装件：红外定位装置、冲孔装置。如用户需要，另外购买。

三、使用环境

本机是在一般常温下进行工作，如果在过高温（大于 50 摄氏度）下工作，将影响本机性能。

四、面板功能介绍

多功能电脑切带机

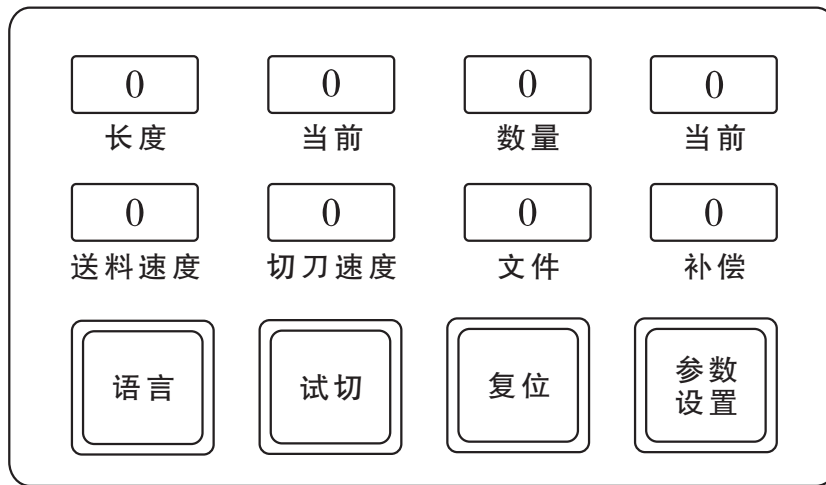

8888
长度

按下该键设置长度

8888
数量

按下该键设置数量

8888
当前

显示当前数量，按下该键当前数量清零

8888
送料速度

数字设置越大，送料速度越快，数字设置越小，送料速度越慢。

2
切刀速度

按下该键，输入数字，数字越小速度快，数字越大速度越慢。

8888
补偿

当实际切出的材料比设置的长度长或短时，输入实际切出来的长度尺寸，系统自行按比例计算，达到设置的长度。数值输入为0时，关闭改功能。

8888
文件

按下该键选择您储存的文件

8888
语言

按下该键选择语言

试切

按下该键手动切刀一次

复位

系统没有出错的情况下按该键。（注：转刀恢复为直刀）

参数设置

按下该键设置里面的参数



电源开关



加热开关



送带机开关



进料：按下该按钮手动向前送料



退料：按下该按钮手动向后退料



启动：按下该按钮机器开始工作



停止：按下该按钮机器停止工作



上压轮按钮：压下该按钮，上压轮抬起，进行手动放料。松开开关，上压轮放下。



收料按钮：材料收满报警后按下该按钮，收料装置松开，进行取料，手动松开按钮后机器启动。

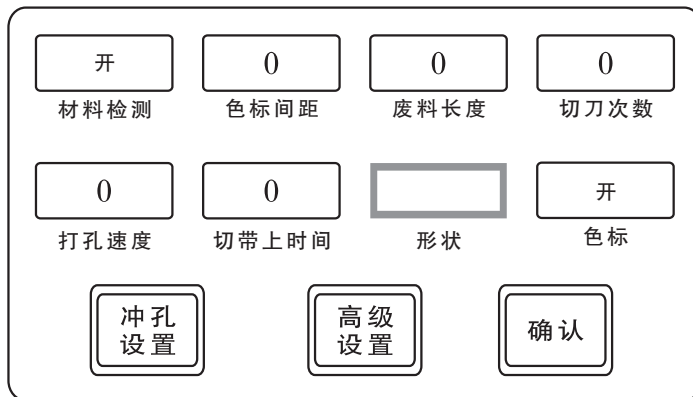

材料检测

“开”为打开材料检测功能，“关”为关闭材料检测功能。



色标间距

是指一段材料中加废料的长度，如无废料直接输入长度。



废料长度

是指切不规则角度时中间所产生废料的长度。



切刀次数

按下按键，输入数字，数字越大切刀次数越多。



打孔速度

数字设置越大，冲针在下面停的时间越久，可使封口效果更好。



切刀上时间

数字设置越大，往刀口送带延时越久，可使有些特殊材料不容易卷轮子上。

机型：转刀



形状

按下该键选择形状。

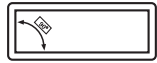

选择直角按下箭头。



选择平行四边形设置角度再按下箭头。

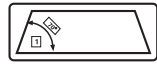

按下梯形设置角度再按下箭头。

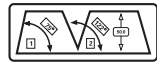

选择不规则角度设置好两个角度后再按下箭头。还需要设置废料的长度。

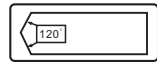

按下设置角度再按下箭头。



色标

“开”为色标功能开启，“关”为色标功能关闭。



冲孔设置

按下该键输入冲孔数据。

总孔数:	<input type="text" value="0"/>	连续打孔功能:	<input type="text" value="关"/>
孔号	孔距	孔号	孔距
一号	0	六号	0
二号	0	七号	0
三号	0	八号	0
四号	0	九号	0
五号	0	十号	0
<input type="button" value="返回"/>			

总孔数

总孔数：产品需要冲孔数量，点击数字可以设定。

孔号

孔号：孔的排序。

孔距

孔距：**1号孔的孔距**：从刀片1到本孔的距离，**2号孔的孔距**：从1号孔到本孔的距离，以此类推。

按下该键是修改系统设置（制造商或专业人员使用）。

按下该键确认所输数据。

五、机型：直刀、切断、冲孔设置

1：设置长度、数量（如：设定长度 100mm 数量 50pcs，打两个孔）

打开电源开关，面板显示窗显示电脑界面

按下 键输入 100 再按下 **enter** 长度设置完成

按下 键输入数量 50 再按下 **enter** 数量设置完成

2：设置直角及冲孔、孔距有长短：按下 进入冲孔设置、（如图：冲 2 个孔，总孔数输入“2”、输入 1 号孔距 25，输入 2 号孔距 50。）、按下 该键、返回上一页，按下 键设置完成。按下 该键机器开始工作。注：（如孔距一样就输入同样孔距尺寸）。如图：

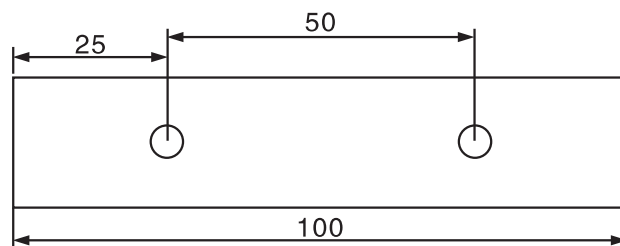

3：收料设置：设置收料数量，该机型能收 3—4 CM 厚度。

六、如何使用色标传感器

- 1、首先测量商标的长度，确认后输入电脑。
- 2、切商标设置：（如：设定长度 100mm）
- 3、把传感器固定在导轨上，然后连接传感器的插座。
- 4、把商标上的切割线与刀锋对准（必须在设置传感器前准备好）

5、设置色标传感器的光束移到标点的中心、调节高度螺母，使光点成清楚的“1”字形。

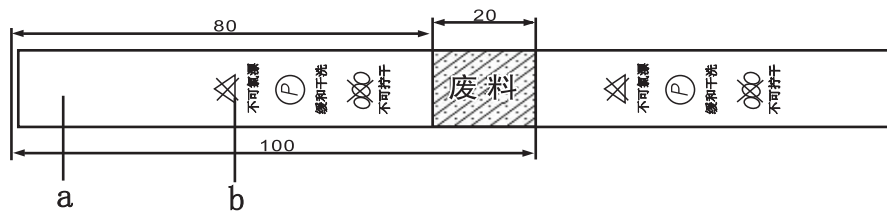

6、把首先打开 开 色标，设置 色标间距 为80，再设置 长度 为100，其中20部分为废料。

7、把光标聚焦到商标的定位点b处，注：最好颜色容易区别处，如图1，按一下“色标设置按键”，再将光标定位到空白a处(如图2)，按一下“色标设置按键”，然后将光标移动到定位点b处，最后固定螺丝。



图1



图2

8、按下复位键，再按启动开始工作。

9、切商标中遇到的问题：

请确定是否调节好传感器

确定商标印刷是否标准

向前或向后移动传感器

检查传感器的灵敏度与高度

检查送料速度(一般速度为50%，必须配送带机)

七、如何调刀和切刀平台平衡

- 1、首先关闭电源。
- 2、将调压阀上气压调至0气压。
- 3、将上刀压至最低使上刀和切刀平台不接触。
- 4、从平台托板上八颗螺丝将平台调平衡使上刀转到任何角度没间隙。
(四颗低的往下拉，四颗高的往上抬)

八、注意事项

- 1、使用前请确认电源电压和连接地线。(注意：接地线必须接地)
- 2、为了确保安全，在机器运转过程中请不要将手或任何物体靠近切刀口。
- 3、在做任何调整时，必须先切断电源、气源以保安全。
- 4、除了正常保养外，请勿任意拆卸任何零部件。
- 5、见切刀座导轨无油时请及时加油，以保滑套润滑。(不要加缝纫机白油，可加汽车用机油类的油)。
- 6、如果刀具使用一段时间后变钝了，可以到专业磨床进行磨刀
(注意：此工作必须专业人士操作)

九、一般故障的排除措施（供参考）

序号	故障现象	对应機種	原因及措施	
1	无电源	全機種	检查电源连接插头接触是否良好	
			检查保险丝是否断开	
2	有电源， 但无法启动， 传感器出错	切刀座滑套卡死或无气压	全機種 1、检查气缸是否通气，如果未通气，请开启阀门。 2、检查切刀座滑套是否卡死，在滑套上注上润滑油。 1. 材料是否用完，请更换新材料 2. 检查是否装有材料或压板掉槽里， 3. 如果都正常检查行程开关是否卡住没弹回去	
		无材料报警		
		冲孔出错		检查是否有气压或冲孔架卡住
		转刀传感器出错		1 检查转刀感应器挡板是否偏位或上面转动处卡死 2 驱动板保险丝有没烧断
		屏面不显示		检查变压器输出是否有电或插口松
3	无法切断带子	全機種	检查气压是否达到，如未达到请增加气压。检查刀片是否锋利，刀片要锋利。热刀刀片是否加热，热刀刀片是否跟平台接触。刀片要加热，刀口要跟平台接触到。	
4	只切断带子的一边	热刀	检查切刀平台是否有高低，如有，请在平台下面的调节螺丝这里调节切不断的这一边适当往下拧，或在高的一边往上适当的松螺丝。调节好了再固紧螺帽。	
5	切断长度与设定值不同	全機種	放松滚轴或利用送带机辅助送料。开启补偿功能。	
6	切断长度不一致	全機種	1 放慢送料速度、2 放松档盘、3 必要是配送带机辅助送料。	
7	切断商标时，未到切割线切断	色标	向刀口的方向移动感应器，相当于差异隙距离。商标印刷不标准。建议用印刷标准的商标。	
8	切断商标时，超出切割线切断	色标	向刀口的反方向移动感应器，相当于差异隙距离，商标印刷不标准。建议用印刷标准的商标。	
9	色标传感器出错	色标	按下弹出窗口，刀口对准切割线，按下复位键再按启动。	
10	转刀复位传感器出错	转角	按复位键重新复位。	
11	手触到设备时，有电流	全機種		

零件图

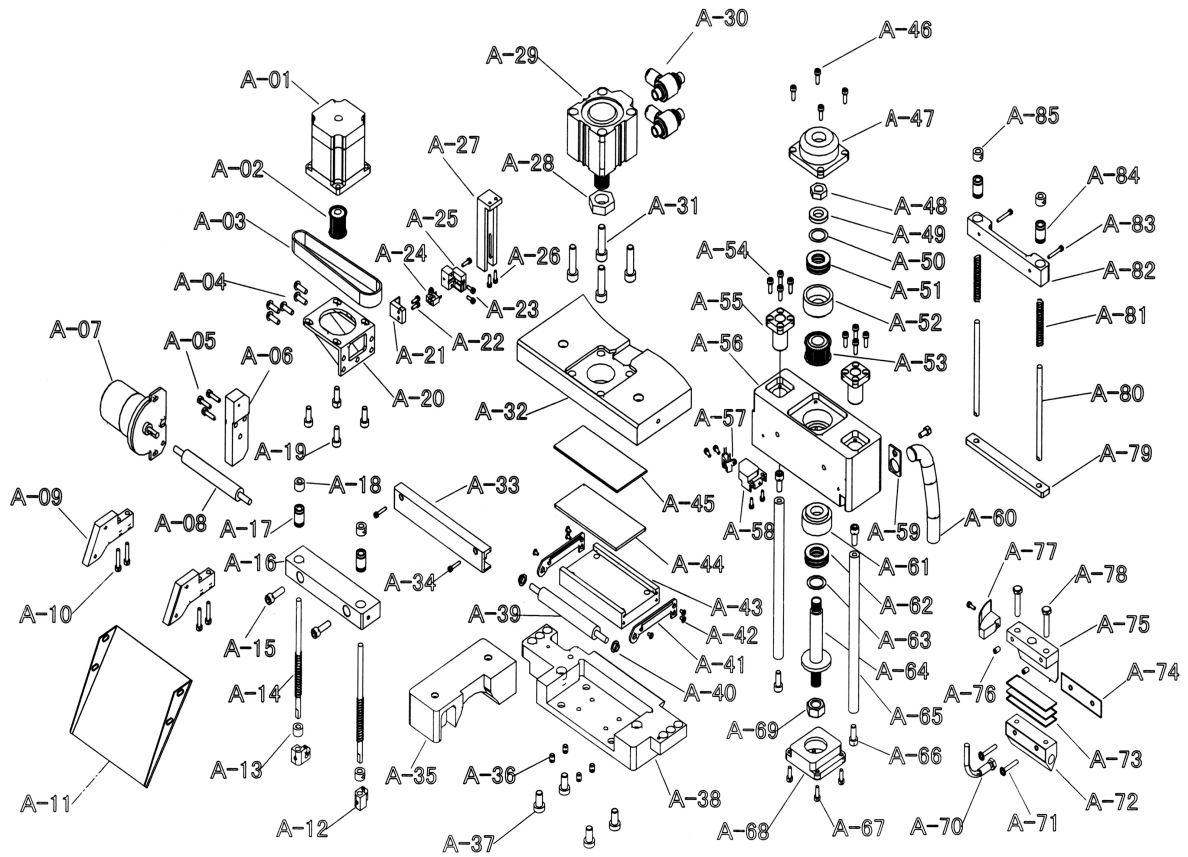

图一

零件图 图一

图号	名称	图号	名称
A-1	转刀步进电机	A-51	平面轴承
A-2	转刀小齿轮	A-52	轴套
A-3	转刀同步带	A-53	转刀大齿轮
A-4	M5 螺钉	A-54	M4 螺钉
A-5	M4 螺钉	A-55	轴套
A-6	直流电机架	A-56	转刀刀架
A-7	直流电机	A-57	槽型传感器
A-8	下滚轮	A-58	传感器架
A-9	滑料板架	A-59	电线管固定片
A-10	M4 螺钉	A-60	弹簧

A-11	滑料板	A-61	轴套
A-12	轴夹紧支架	A-62	平面轴承
A-13	挡圈	A-63	波形垫片
A-14	竖轴	A-64	转刀支架轴
A-15	M4 螺钉	A-65	固定轴
A-16	滚轮导架	A-66	M6 螺钉
A-17	直线轴承	A-67	M4 螺钉
A-18	挡圈	A-68	转刀刀架下盖板
A-19	M5 螺钉	A-69	刀座固定螺帽
A-20	转刀电机架	A-70	热电偶
A-21	挡板	A-71	M4 螺钉
A-22	M3 螺钉	A-72	转刀刀片
A-23	M3 螺钉	A-73	隔热板
A-24	槽型传感器	A-74	后隔热板
A-25	传感器固定板	A-75	转刀刀座
A-26	M3 螺钉	A-76	内六角螺钉
A-27	传感器座	A-77	转刀传感器挡板
A-28	气缸螺帽	A-78	M6 螺钉
A-29	切刀气缸	A-79	压料板
A-30	节流阀	A-80	压料板轴
A-31	M10 螺钉	A-81	压料板弹簧
A-32	切刀气缸托板	A-82	压料板架
A-33	电线槽	A-83	M3 螺钉
A-34	M3 螺钉	A-84	直线轴承
A-35	皮带轮罩	A-85	挡圈
A-36	内六角螺钉		
A-37	M10 螺钉		
A-38	下刀平台		
A-39	上滚轮		
A-40	轴套		
A-41	支架侧盖		
A-42	M4 螺钉		
A-43	加热板支架		
A-44	牛津垫条		
A-45	加热板		
A-46	M5 螺钉		
A-47	转刀刀架上盖板		
A-48	螺帽		
A-49	垫片		
A-50	波形垫片		

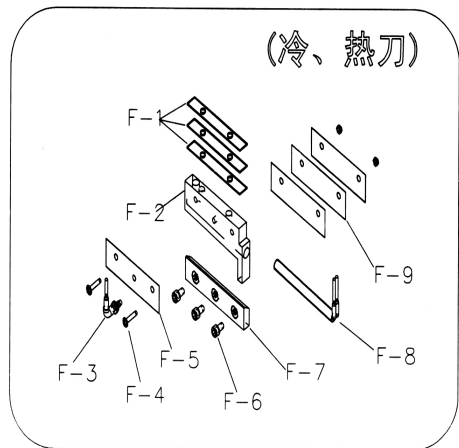
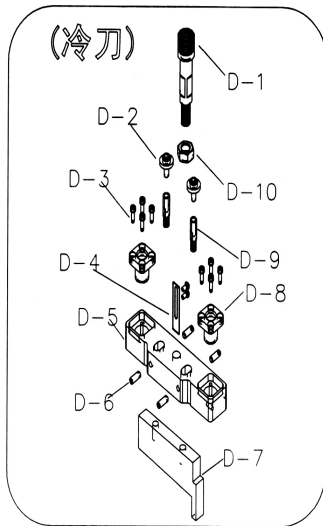
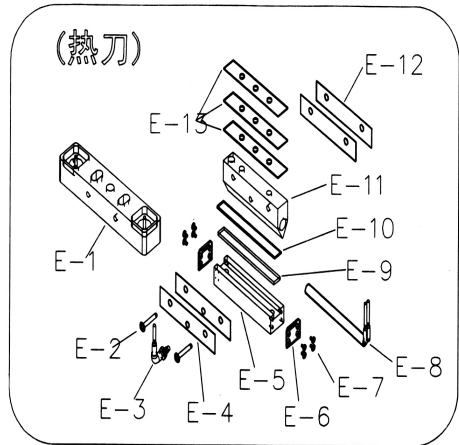
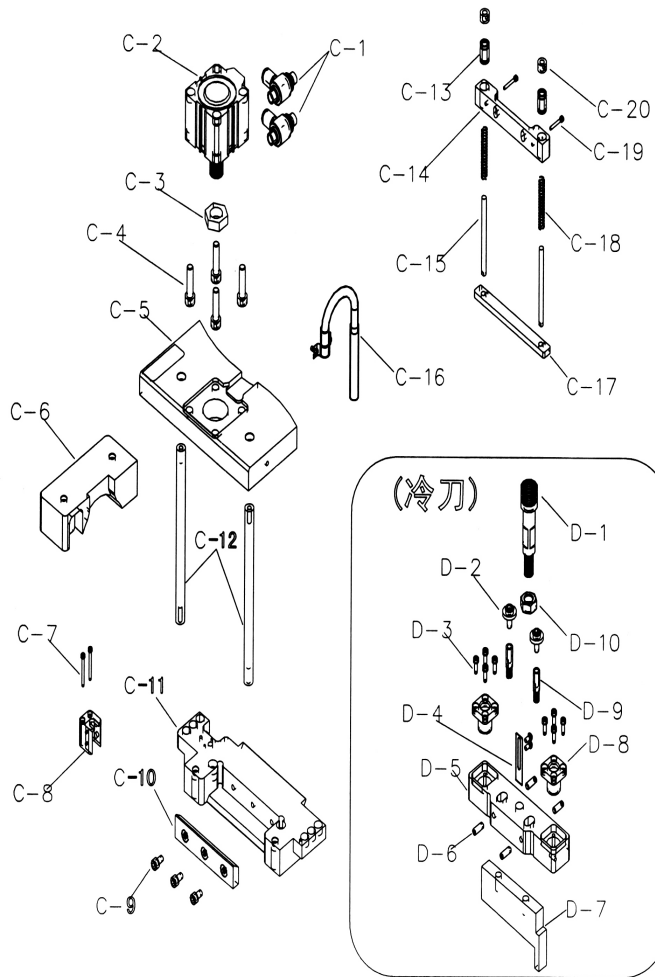

图二

零件图 图二

图号	名称	图号	名称
C-1	节流阀	G-9	上隔热板
C-2	切刀气缸	G-10	冷热刀上刀片
C-3	气缸螺帽	G-11	热电偶
C-4	M8 螺钉	G-12	M4 螺钉
C-5	切刀气缸托板	G-13	隔热板
C-6	皮带轮罩	冷、热刀H	
C-7	M3 螺钉	H-1	上隔热板
C-8	传感器座	H-2	冷热刀上刀片
C-9	M5 螺钉	H-3	热电偶
C-10	下刀片	H-4	M4 螺钉
C-11	下刀平台	H-5	隔热板
C-12	固定轴	H-6	M5 螺钉
C-13	直线轴承	H-7	冷热刀下刀片
C-14	压料板架	H-8	发热管
C-15	压料板轴	H-9	后隔热板
C-16	电线管+弹簧		
C-17	挡圈		
C-18	M3 螺钉		
C-19	压料板弹簧		
C-20	压料板		
冷刀 F			
F-1	M6 螺钉+垫片		
F-2	M4 螺钉		
F-3	感应片		
F-4	冷刀刀架		
F-5	内六角螺钉		
F-6	刀架连接杆		
F-7	螺帽		
F-8	刀片螺钉		
F-9	滑动套		
F-10	上刀片		
热刀			
G-1	热刀刀架		
G-2	M4 螺钉		
G-3	热电偶		
G-4	前隔热板		
G-5	加热板支架		
G-6	支架侧盖		
G-7	M3 螺钉		
G-8	发热管		

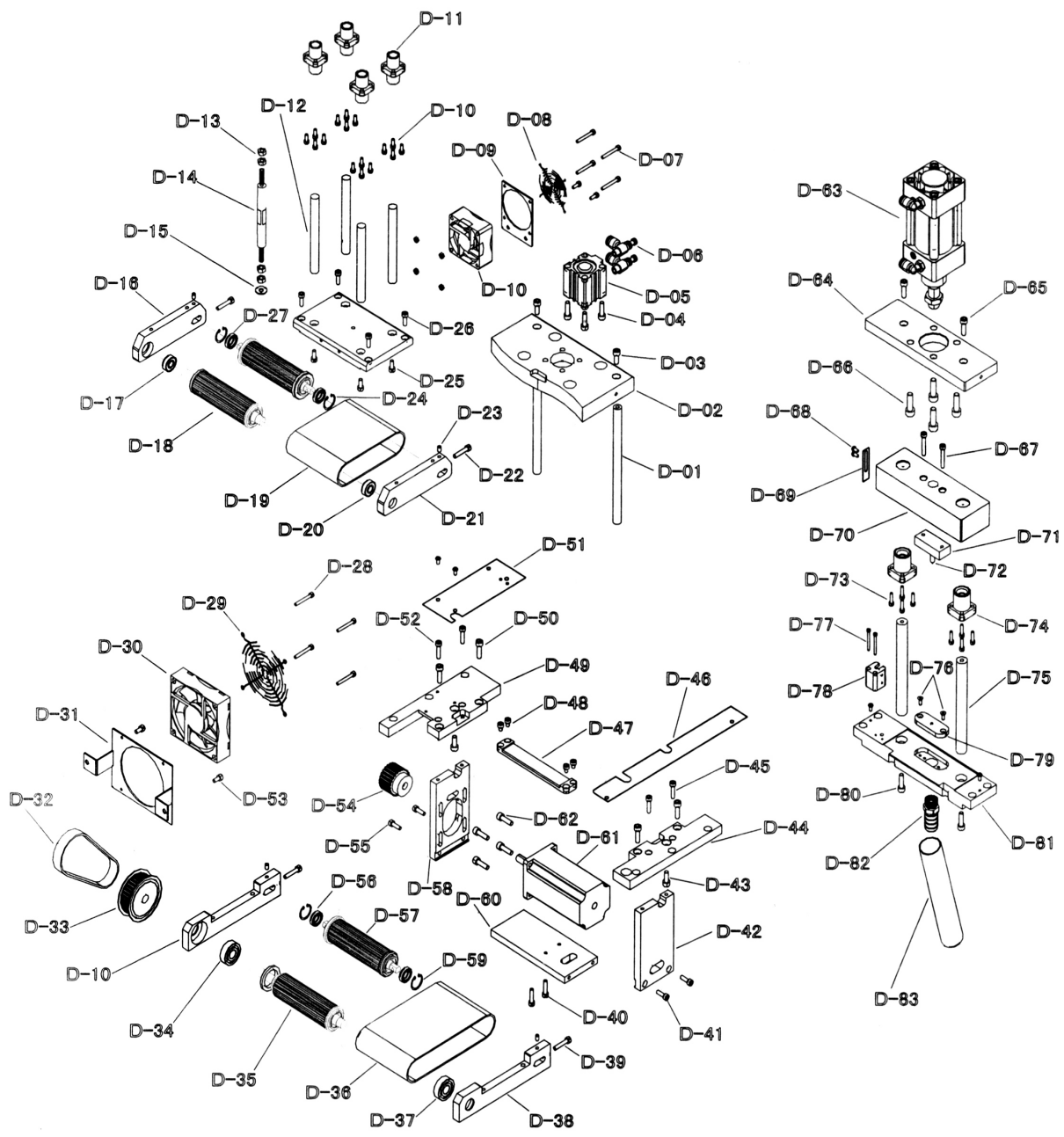

图三

零件图 图三

图号	名称	图号	名称
D-1	固定轴	D-51	中侧盖板
D-2	切刀气缸托板	D-52	M3 螺钉
D-3	M10 螺钉	D-53	M4 螺钉
D-4	M8 螺钉	D-54	下同步齿轮
D-5	压料气缸	D-55	M6 螺钉
D-6	压料气缸节流阀	D-56	轴承 6099ZZ
D-7	M4 螺钉	D-57	送料轮
D-8	6X6 风扇网	D-58	左圆筒座
D-9	风扇固定架	D-59	轴承 6099ZZ
D-10	6X6 风扇 或 送料轮架 (左)	D-60	圆筒座固定板
D-11	固定套	D-61	步进电机
D-12	固定轴	D-62	M6 螺钉
D-13	M6 螺帽	D-63	冲孔气缸
D-14	调节轴	D-64	冲孔气缸架
D-15	M6 螺帽 (反牙)	D-65	M6 螺钉
D-16	压料轮架 (左)	D-66	M8 螺钉
D-17	轴承 6900ZZ	D-67	M6 螺钉
D-18	压料轮	D-68	M3 螺钉
D-19	压料同步带	D-69	挡片
D-20	轴承 6900ZZ	D-70	冲孔活动架
D-21	压料轮架 (右)	D-71	冲针固定块
D-22	M5 螺钉	D-72	冲针
D-23	M5 内六角螺钉	D-73	M4 螺钉
D-24	轴承 608ZZ	D-74	滑动套
D-25	M5 螺钉	D-75	固定轴
D-26	M5 螺钉	D-76	M4 螺钉
D-27	轴承 608ZZ	D-77	M3 螺钉
D-28	M4 螺钉	D-78	传感器座
D-29	风扇网	D-79	冲孔下模
D-30	9X9 风扇	D-80	M6 螺钉
D-31	风扇固定架	D-81	冲孔架
D-32	同步带	D-82	废料出口
D-33	上同步齿轮	D-83	废料导向管
D-34	轴承 6201ZZ		
D-35	送料轮		
D-36	送料同步带		
D-37	轴承 6201ZZ		
D-38	送料轮架 (右)		
D-39	M5 螺钉		

D-40	M6 螺钉		
D-41	M6 螺钉		
D-42	右圆筒座		
D-43	M5 螺钉		
D-44	送带架底座 (右)		
D-45	M5 螺钉		
D-46	前侧盖板		
D-47	固定块		
D-48	M5 螺钉		
D-49	送带架底座 (左)		
D-50	M5 螺钉		

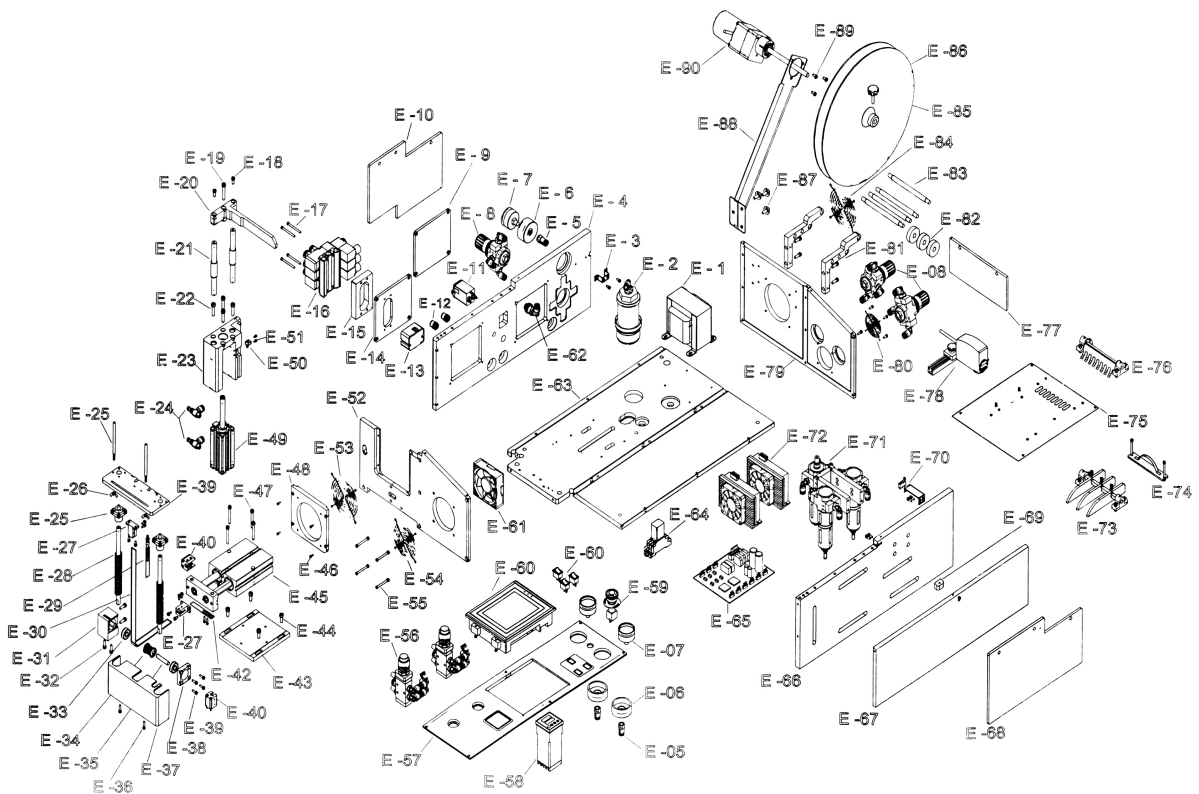

图四

零件图 图四

图号	名称	图号	名称
E-1	变压器	E-46	M4 螺钉
E-2	降噪器	E-47	M5 螺钉
E-3	降噪器固定板	E-48	过滤网架
E-4	左侧板	E-49	压料气缸
E-5	气压表接头	E-50	槽型传感器
E-6	气压表固定盖	E-51	M3 螺钉
E-7	气压表	E-52	前盖
E-8	调压阀	E-53	过滤网
E-9	加油盖	E-54	过滤网
E-10	有机玻璃左	E-55	M4 螺钉
E-11	滤波器	E-56	机械阀
E-12	航空插	E-57	面板
E-13	LED 灯	E-58	温控器
E-14	电磁阀固定板	E-59	急停开关
E-15	电磁阀垫块	E-60	开关
E-16	电磁阀+集成块	E-61	风扇
E-17	M4 螺钉	E-62	气管接头
E-18	M5 螺钉	E-63	底板
E-19	M6 螺钉	E-64	继电器
E-20	压料压板	E-65	电路板
E-21	压料固定轴	E-66	中间板
E-22	M6 螺钉	E-67	右侧盖
E-23	收料气缸固定架	E-68	有机玻璃右
E-24	节流阀	E-69	面板固定块
E-25	挡料轴	E-70	行程开关
E-26	蝴蝶螺丝	E-71	过滤瓶+油瓶
E-27	压料皮带固定架	E-72	驱动板
E-28	压料压缩弹簧	E-73	挡料板
E-29	压料限位板	E-74	过料压板
E-30	压料皮带	E-75	上盖板
E-31	压料齿轮架	E-76	压板
E-32	M4 螺钉	E-77	有机玻璃后
E-33	轴承 628ZZ	E-78	色标传感器
E-34	压料齿轮	E-79	后盖
E-35	压料齿轮轴	E-80	调压阀
E-36	M4 螺钉	E-81	压板座
E-37	压料保护罩	E-82	挡圈
E-38	压料齿轮盖	E-83	过带轴
E-39	M4 螺钉	E-84	风扇网
E-40	传感器固定架横	E-85	挡盘
E-41	传感器固定架	E-86	挡芯
E-42	料料传感器挡板	E-87	M6 螺钉带垫片
E-43	收料气缸固定架	E-88	送带放料臂
E-44	M5 螺钉	E-89	M5 螺钉
E-45	收料气缸	E-90	解带电机

I. Brief Introduction

The multifunction auto-cutting machine is a new special machine integrating pneumatic, mechanical and electrical controls, which can control the mechanical and cylinder actions automatically through the computer program and automatically cut off the belt-shaped objects such as woven belt, plastic hose, shoe lace, trademark at different widths, lengths and angles according to the length and quantity required. The precision of your products will be higher thanks to the compensation function designed according to the elasticity of the materials to be cut. Options: (the infrared positioning device: the trademarks of different widths can be cut off accurately through positioning by the infrared sensor system. The punching unit: the punch die can be replaced according to customer requirements to punch holes of different sizes). With the function of automatic stopping when there is no material and the features of cutting of thick materials, high precision, high cutting speed, flat cut surface free of burr, cutting of nylon materials without loose yarns, simple operation, etc, this machine is the first choice to help you to increase production efficiency, improve product quality and save labor cost.

II. Specification

Model	Power KW	Max. material height mm	Recommended air pressure Mpa	Max. cutting width right angle/ oblique angle mm	Cutting length mm	Punching hole diameter mm	Max. temperature of knife blade °C	50mm cutting speed/min./ material receiving	Voltage V	Packing dimension MM
150LR	1.2	40	0.3-0.6	95	20-99999	2 - 8	350	150	110/220	820x570x780
150H	1.2	30	0.3-0.6	95	20-99999	2 - 8	420	150	110/220	820x570x780
150HX	1.05	-	0.3-0.6	65 / 40	20-99999	2 - 8	420	150	110/220	820x570x780
150L	0.3	40	0.3-0.6	95	20-99999	2 - 8	-	150	110/220	820x570x780

Note: Options: infrared positioning device and punching unit. User may purchase these options separately if needed.

III. Service Environment

This Machine works at room temperature, and its performance will be influenced if the temperature is too high (higher than 50°C).

IV. Introduction of Panel Functions

Multifunction Auto-cutting Machine

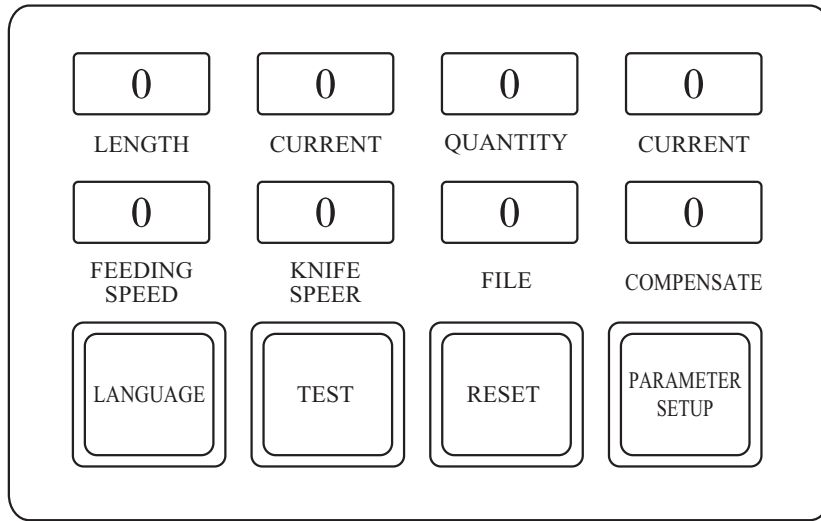

Length

Press this key to set the length.

Quantity

Press this key to set the quantity.

Current

Display current quantity; press this key and the current quantity will be reset to be zero.

Feeding
Speed

Press the key, input the number, the larger the number, the faster the speed, the smaller the number, the slower the speed.

Knife
Speed

Press the key, input the number, the smaller the number, the faster the speed, the larger the number, the slower the speed.

Compensation

When the actual cut material is longer or shorter than the set length, input the actual cut length, and the system will calculate by proportion to achieve the set length. When the value input is 0, the change function will be turned off.









File

Press this key to select the stored file.





Press this key to cut once manually.

Press this key when the system has no error. (Note: the rotating knife will be recovered to be straight knife)

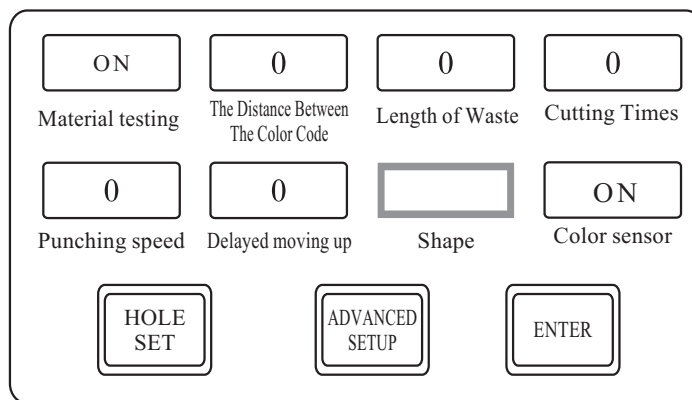
Press this key to set the parameters.

-  Power switch
-  Heating switch
-  Belt transmitter switch
-  Manual feeding: Press this key to feed the materials forward manually.
-  Manual returning: Press this key to feed the materials backward manually.
-  Start: Press this key and the machine will start to work.
-  Stop: Press this key and the machine will stop working.
-  Upper pressing wheel button: Press down this button, the upper pressing wheel will be lifted up to manually place the materials. Release the switch and the upper pressing wheel will be put down.
-  Material receiving button: Press this button when it is alarmed that the materials are full, the material receiving device will be released to take the materials; release the button and the machine will be started.





-  “On” means to open the material testing function, “OFF” means to close the material testing function.
-  It means the length of the waste added to one segment of materials; directly input the length if there is no waste.
-  It means the length of the waste generated during the cutting of irregular angle.
-  Press this key, input the number, the larger the number, the more times of cutting.



Punching speed The larger the number is, the longer the punching needle stops at the bottom, which can make the sealing effect better.

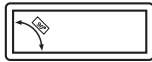

Delayed moving up The larger the number is, the longer the time delay of feeding belt to the edge of the knife will be, so that some special materials are not easy to roll on the wheel.



Machine type: Rotating knife



Shape: Press this key to select the shape.

  Select the right angle and press the arrow.

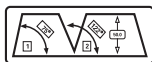
  Select the parallelogram to set the angle and then press the arrow.

  Press the trapezium to set the angle and then press the arrow.

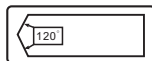
  Select the irregular angle to set two angles and then press the arrow. Also set the length of the waste.

  Press to set the angle and then press the arrow.

Shape: Press this key to select the shape.

Color sensor "On" means the color sensor function is on, "OFF" means the color sensor function is off.

Hole set Press this key to input the data of punched hole.

Quantity of holes <input type="text"/>		Continuous punching functions <input type="text" value="OFF"/>	
Hole Number	Distance Between Holes	Hole Number	Distance Between Holes
NO.1		NO.6	
NO.2		NO.7	
NO.3		NO.8	
NO.4		NO.9	
NO.5		NO.10	
<input type="text" value="Return"/>			

The quantity of punched holes needed by product, which can be set by clicking on the figures.

The sequence of the hole.

The pitch of No. 1 hole: the distance from the blade 1 to this hole;
The pitch of No. 2 hole: the distance from No.1 hole to this hole; and so on.

Advanced Settings: Press this key to modify the system settings (to be used by manufacturer or professionals)

Enter Press this key to confirm the inputted data.

V. Machine Type: Straight Knife, Cutting and Punched Hole Settings

1: Set the length and quantity (for example: set the length to be 100mm and the quantity to be 50pcs, and punch two holes).

Turn on the power switch, and the display window of the panel will display the computer interface.

Press **8888** Length key, input 100, then press Enter key, and the length setting is finished.

Press **8888** Quantity key, input 50, then press Enter key, and the quantity setting is finished.

2: Set the straight angle and punched hole, with different pitches: Press **Punched Hole Settings** to enter the punched hole settings, (as shown in the figure below: to punch two holes, input “2” for the total holes, input 25 for the pitch of No. 1 hole and 50 for the pitch of No. 2), press **OK** key, then go back to the previous page, press **OK** key again, and the setting is finished. Press **Start** key and the machine will start to work. Note: (if the pitch is the same, input the same pitch value), as shown below:

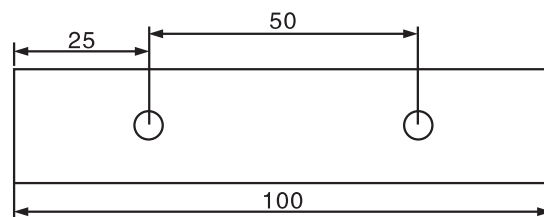

3. Material Receiving settings: Set the quantity of the materials received, 3-4CM thick materials available for this machine type.

VI. How to Use the Color Code Sensor

1. First measure the length of the trademark, confirm it and then input it into the computer.
2. Trademark cutting setting: (for example: set the length to be 100mm).
3. Fix the sensor on the guide rail and connect it to the socket of the sensor.
4. Align the cutting line on the trademark with the blade point (prepared before the setting of sensor).
5. Move the light beam of the color code sensor to the center of the light spot and adjust the height nut to make the light spot form a clear “1” shape.

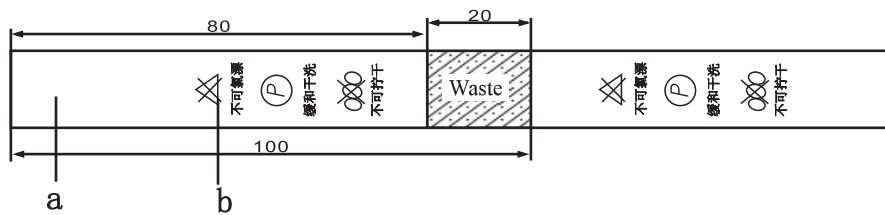

6. First open the color sensor , set the Distance between the color code to 80, then set the length to 100

7. Move the cursor to the positioning point of the trademark (a place),the best color is easy to distinguish, and click the "color mark setting button", as shown in Figure 1; Then move the cursor to the blank: b place ,(as shown in Figure 2), press the "color code setting button", and finally move the cursor to the positioning point (as shown in Figure 2), then fix the screws.



Fig.1



Fig.2

8. Press the reset key, and then press start to work.

9. Problems during cutting of trademark:

Please confirm if the sensor has been adjusted properly.

Confirm if the trademark printing is standard.

Move the sensor forwards or backwards.

Check the sensitivity and height of the sensor.

Check the material feeding speed (the general speed is 50%, the belt transmitter must be provided)

VII. How to Adjust the Balance of the Knife and Cutting Knife Platform

1. First turn off the power supply.

2. Adjust the air pressure on the pressure regulating valve to be zero air pressure.

VIII. Precautions

1. Please confirm the power voltage and connection of ground wire before use. (Note: the ground wire must be grounded)
2. Please don't put your hand or any object close to the cutting knife edge during operation of the machine for the safety.
3. Be sure to cut off the power source and air source before any adjustment for the safety.
4. Please don't dismantle any components unless in normal maintenance.
5. Please fill oil timely when there is no oil on the guide rail of cutting knife base to keep the sliding sleeve lubricated. (Fill the engine oil for automobiles rather than the white oil of sewing machine)
6. Sharpen the knife with the special grinding machine if the knife is blunt after used for a period of time (note: such work must be performed by professionals)
7. In case of any difficulty in the operation, please contact our company and we will serve you wholeheartedly.

IX. Measures for Removal of Common Faults (for reference)

No.	Fault Phenomenon	Machine Type	Causes and Measures
1	No power supply	All types of machine	Check if the contact of connecting plug of power supply is good. Check if the fuse is blown.
2	There is power supply, but the machine fails to be started and the sensor has an error.	The sliding sleeve of cutting knife base is stuck or there is no air pressure.	1. Check if the air cylinder is connected to the air and if not, please open the valve. 2. Check if the sliding sleeve of cutting knife base is stuck, and inject the lubricating oil on the sliding sleeve.
		Alarm of no material	1. Check if the materials are used up, and please replace with new materials when needed. 2. Check if there is material or if the pressing plate drops into the slot. 3. If all is confirmed normal, check if the travel switch is stuck and doesn't bounce back.
		There is punching error.	Check if there is air pressure or if the punching holder is stuck.
		The sensor of rotating knife has an error.	1. Check if the baffle plate of the sensor of rotating knife deviates or is jammed in the rotating position above. 2. Check if the fuse of driver board is blown.
		The panel has no display.	Check if the transformer outputs electricity or if the socket is loose.
3	Fail to cut off the belt.	All types of machine	Check if the air pressure reaches the required value, and if not, please increase the air pressure. Check if the blade is sharp, if the blade of heat knife is heating and if the blade of heat knife contacts the platform. The blade should be sharp, the blade of heat knife should be heating and the knife edge should contact the platform.
4	Only one side of the belt is cut off.	Heat knife	Check if the height of the platform of cutting knife is different, and if yes, please screw down the screw below the platform on the side of the belt not cut off or appropriately loosen the screw on the higher side. Then fasten the nut.
5	The cutting length is different from the set value.	All types of machine	Loosen the roller or use the belt transmitter to feed the materials. Enable the compensation function.
6	The cutting length is not uniform.	All types of machine	1. Slow down the feeding; 2. Loosen the baffle plate; 3. Use the belt transmitter to feed the materials when necessary.
7	The trademark is cut off before reaching the cutting line.	Color code	Move the sensor in the direction of the knife edge till the distance of the difference gap. The trademark printing is not standard. The trademark of standard printing is recommended.
8	The trademark is cut off after exceeding the cutting line.	Color code	Move the sensor in the opposite direction of the knife edge till the distance of the difference gap. The trademark printing is not standard. The trademark of standard printing is recommended.
9	The color code sensor has an error.	Color code	Press down the pop-up window, align the knife edge with the cutting line, press Reset key and then press Start key.
10	The reset sensor of rotating knife has an error.	Rotating angle	Press Reset key to reset.
11	There is current when touching the equipment.	All types of machine	

Parts Drawing

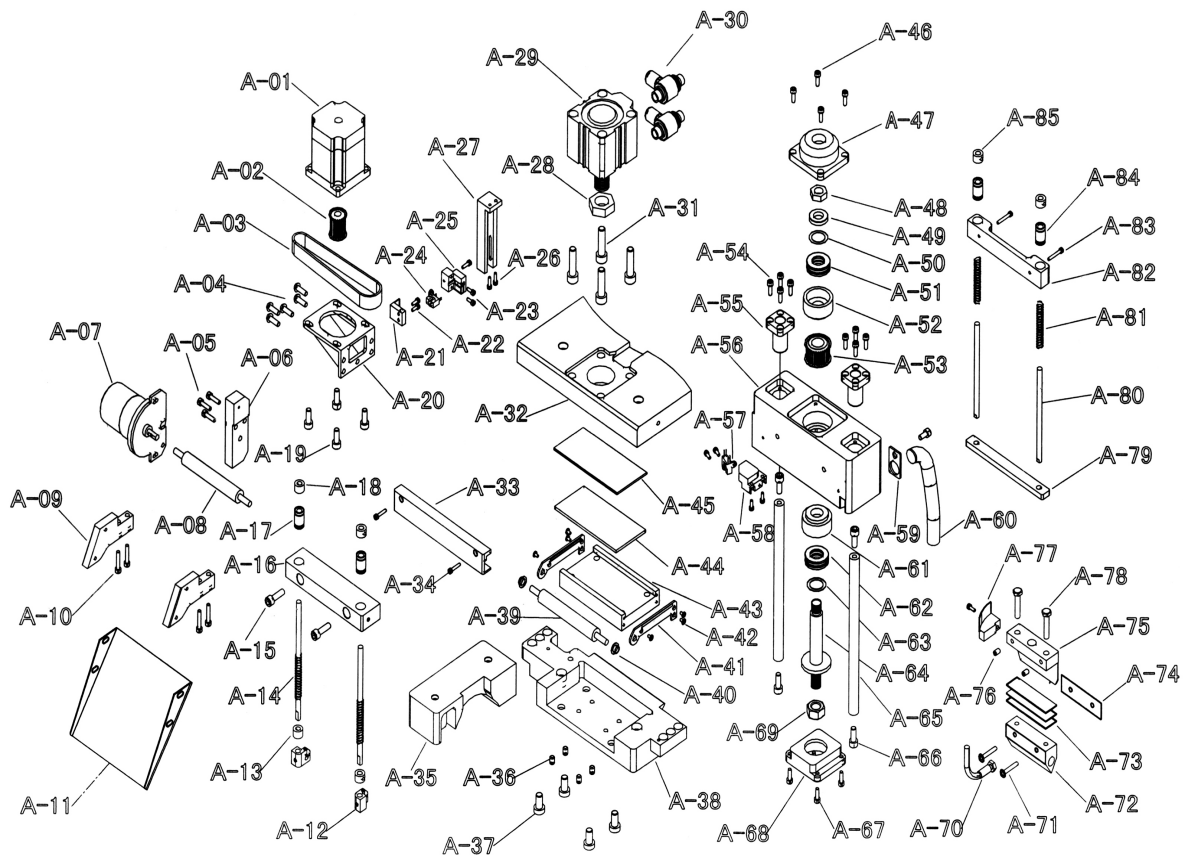

Fig. I

Parts Drawing Fig. 1

Drawing No.	Name	Drawing No.	Name
A-1	Stepping motor of rotating knife	A-51	Plane bearing
A-2	Pinion of rotating knife	A-52	Shaft sleeve
A-3	Synchronous belt of rotating knife	A-53	Large gear of rotating blade
A-4	M5 screw	A-54	M4 screw
A-5	M4 screw	A-55	Shaft sleeve
A-6	DC motor frame	A-56	Rotating knife rest
A-7	DC motor	A-57	Trough type sensor
A-8	Bottom roller	A-58	Sensor rack
A-9	Material sliding plate rack	A-59	Fixed piece of wiring tube
A-10	M4 screw	A-60	Spring

A-11	Material sliding plate	A-61	Shaft sleeve
A-12	Shaft clamping bracket	A-62	Plane bearing
A-13	Retaining ring	A-63	Corrugated gasket
A-14	Vertical shaft	A-64	Bracket axle of rotating knife
A-15	M4 screw	A-65	Fixed axle
A-16	Guide frame of roller	A-66	M6 screw
A-17	Retaining ring	A-67	M4 screw
A-18		A-68	Bottom cover plate of rotating knife rest
A-19	M5 screw	A-69	Fixed nut of knife holder
A-20	Motor frame of rotating knife	A-70	Thermal couple
A-21	Baffle plate	A-71	M4 screw
A-22	M3 screw	A-72	Rotating knife blade
A-23	M3 screw	A-73	Thermal baffle
A-24	Trough type sensor	A-74	Rear thermal baffle
A-25	Fixing plate of sensor	A-75	Rotating knife holder
A-26	M3 screw	A-76	Socket head cap screw
A-27	Sensor seat	A-77	Baffle plate of rotating knife sensor
A-28	Cylinder nut	A-78	M6 screw
A-29	Cylinder of cutting knife	A-79	Material pressing plate
A-30	Throttle valve	A-80	Material pressing plate axle
A-31	M10 screw	A-81	Material pressing plate spring
A-32	Support plate of cutting knife cylinder	A-82	Material pressing plate frame
A-33	Wire slot	A-83	M3 screw
A-34	M3 screw	A-84	Linear bearing
A-35	Pulley cover	A-85	Retaining ring
A-36	Socket head cap screw		
A-37	M10 screw		
A-38	Lower knife platform		
A-39	Upper roller		
A-40	Shaft sleeve		
A-41	Side cover of support		
A-42	M4 screw		
A-43	Heating plate support		
A-44	Oxford filler strip		
A-45	Heating plate		
A-46	M5 screw		
A-47	Upper cover plate of rotating knife rest		
A-48	Nut		
A-49	Gasket		
A-50	Corrugated gasket		

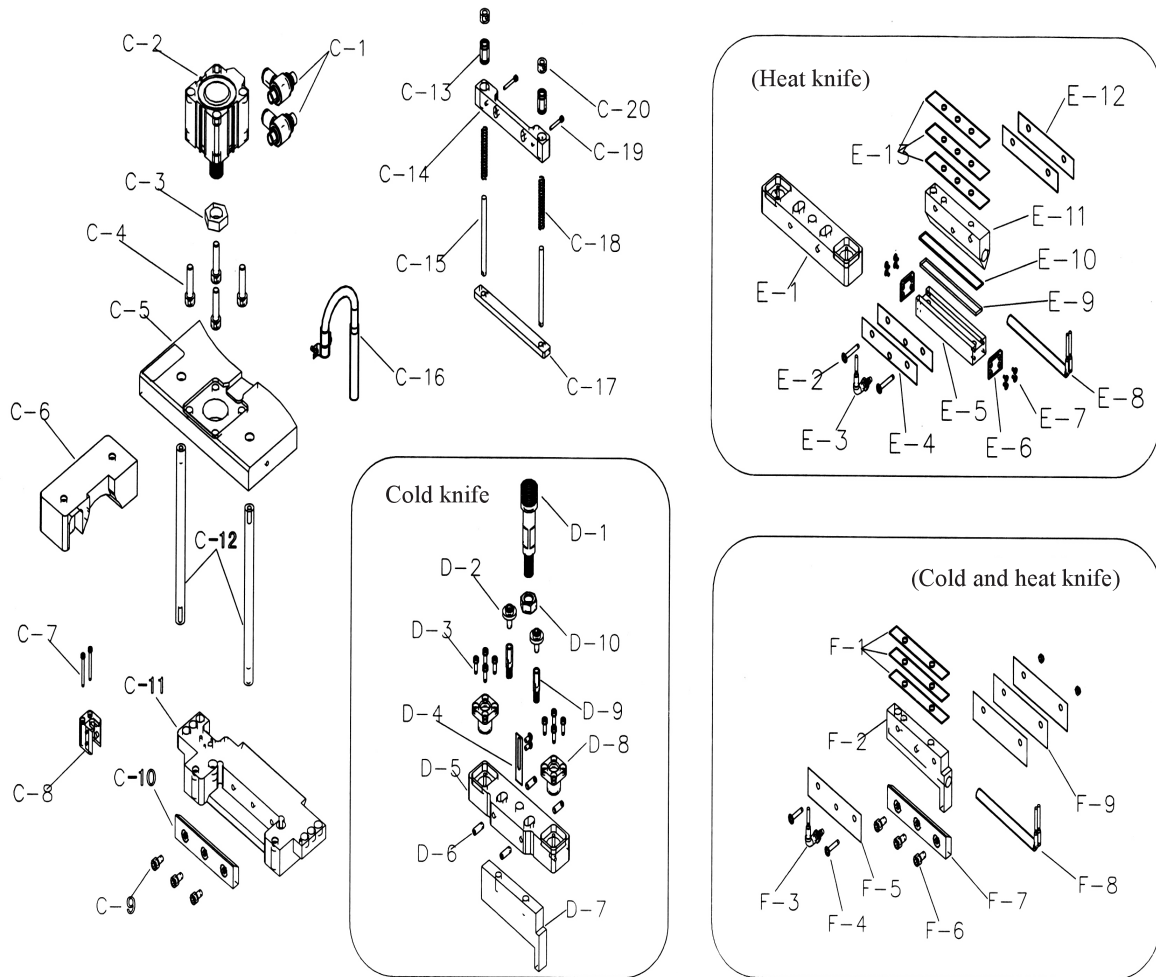

Fig. II

Parts Drawing Fig. II			
Drawing No.	Name	Drawing No.	Name
C-1	Throttle valve	G-9	Upper thermal baffle
C-2	Cutting knife cylinder	G-10	Top knife blade of cold and heat knife
C-3	Cylinder nut	G-11	Thermal couple
C-4	M8 screw	G-12	M4 screw
C-5	Support plate of cutting knife cylinder	G-13	Thermal baffle
C-6	Pulley cover	Cold and hot knife H	
C-7	M3 screw	H-1	Upper thermal baffle
C-8	Sensor seat	H-2	Top knife blade of cold and heat knife
C-9	M5 screw	H-3	Thermal couple
C-10	Bottom knife blade	H-4	M4 screw
C-11	Bottom knife platform	H-5	Thermal baffle
C-12	Fixed axle	H-6	M5 screw
C-13	Linear bearing	H-7	Bottom knife blade of cold and heat knife
C-14	Material pressing plate frame	H-8	Heating tube
C-15	Material pressing plate axle	H-9	Rear thermal baffle
C-16	Wiring tube + spring		
C-17	Retaining ring		
C-18	M3 screw		
C-19	Material pressing plate spring		
C-20	Material pressing plate		
Cold knife F			
F-1	M6 screw + gasket		
F-2	M4 screw		
F-3	Sensor chip		
F-4	Cold knife rest		
F-5	Socket head cap screw		
F-6	Connecting rod of knife rest		
F-7	Nut		
F-8	Blade screw		
F-9	Sliding sleeve		
F-10	Top knife blade		
Heat knife			
G-1	Heat knife rest		
G-2	M4 screw		
G-3	Thermal couple		
G-4	Front thermal baffle		
G-5	Heating plate support		
G-6	Side cover of support		
G-7	M3 screw		
G-8	Heating tube		

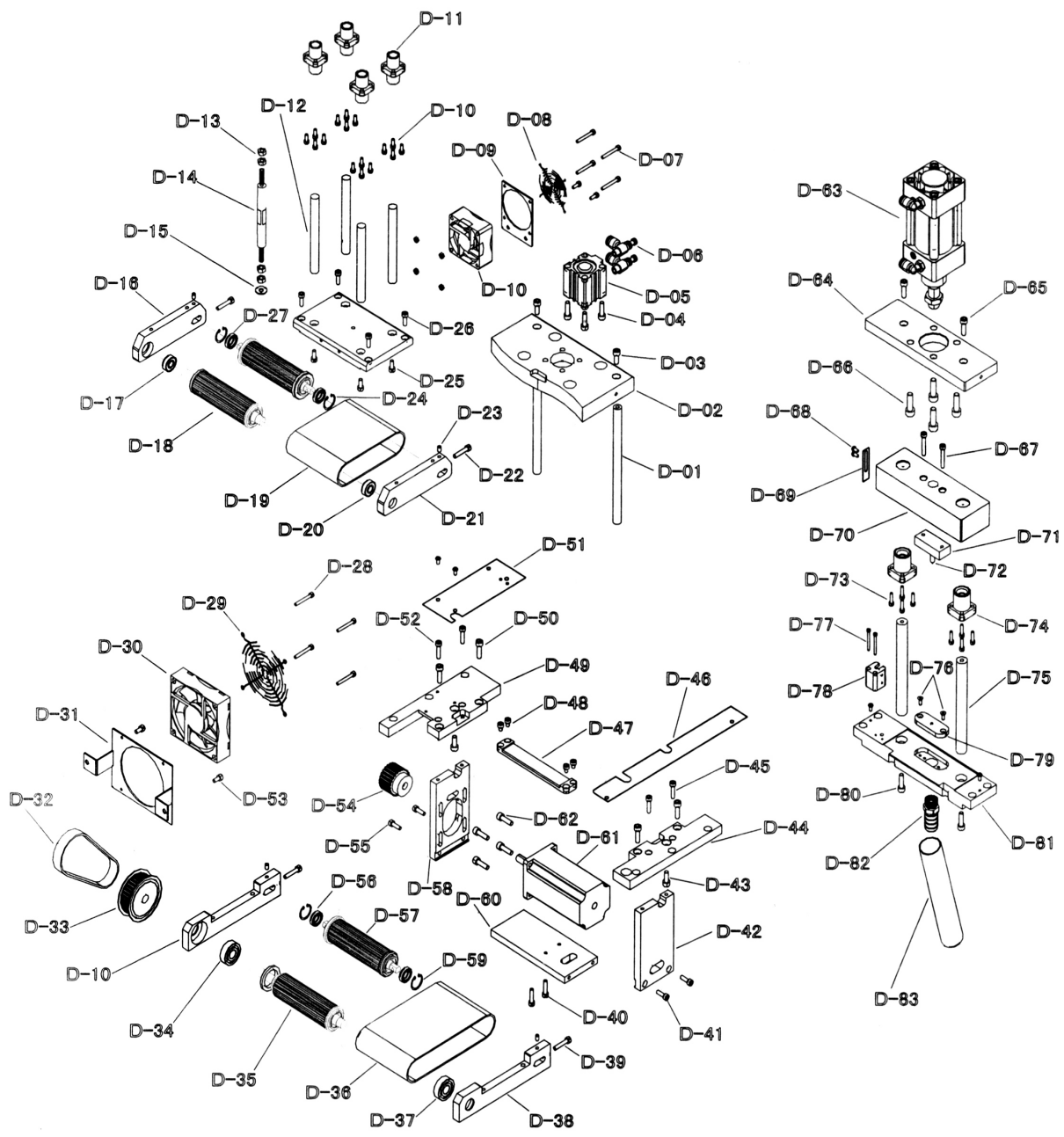

Fig. III

Parts Drawing Fig. III			
Drawing No.	Name	Drawing No.	Name
D-1	Fixed axle	D-51	Middle cover plate
D-2	Support plate of cutting knife cylinder	D-52	M3 screw
D-3	M10 screw	D-53	M4 screw
D-4	M8 screw	D-54	Lower synchronous gear
D-5	Material pressing cylinder	D-55	M6 screw
D-6	Throttle valve of material pressing cylinder	D-56	Bearing 6099ZZ
D-7	M4 screw	D-57	Feeding wheel
D-8	6×6 fan net	D-58	Left cylinder block
D-9	Fixed frame of fan	D-59	Bearing 6099ZZ
D-10	6×6 fan or feeding wheel frame (left)	D-60	Fixing plate of cylinder block
D-11	Fixing sleeve	D-61	Stepper motor
D-12	Fixed axle	D-62	M6 screw
D-13	M6 nut	D-63	Punching cylinder
D-14	Regulating shaft	D-64	Punching cylinder frame
D-15	M6 nut (left-hand thread)	D-65	M6 screw
D-16	Material pressing wheel frame (left)	D-66	M8 screw
D-17	Bearing 6900ZZ	D-67	M6 screw
D-18	Material pressing wheel	D-68	M3 screw
D-19	Material pressing synchronous belt	D-69	Backup plate
D-20	Bearing 6900ZZ	D-70	Flexible mount of punching
D-21	Material pressing wheel frame (right)	D-71	Fixed block of punching pin
D-22	M5 screw	D-72	Punching pin
D-23	M5 socket head cap screw	D-73	M4 screw
D-24	Bearing 608ZZ	D-74	Sliding sleeve
D-25	M5 screw	D-75	Fixed axle
D-26	M5 screw	D-76	M4 screw
D-27	Bearing 608ZZ	D-77	M3 screw
D-28	M4 screw	D-78	Sensor seat
D-29	Fan net	D-79	Bottom punching die
D-30	9×9 fan	D-80	M6 screw
D-31	Fixed frame of fan	D-81	Punching frame
D-32	Synchronous belt	D-82	Waste outlet
D-33	Upper synchronous gear	D-83	Waste guide tube
D-34	Bearing 6201ZZ		
D-35	Feeding wheel		
D-36	Feeding synchronous belt		
D-37	Bearing 6201ZZ		
D-38	Feeding wheel frame (right)		
D-39	M5 screw		

D-40	M6 screw		
D-41	M6 screw		
D-42	Right cylinder block		
D-43	M5 screw		
D-44	Belt feeding frame base (right)		
D-45	M5 screw		
D-46	Front cover plate		
D-47	Fixed block		
D-48	M5 screw		
D-49	Belt feeding frame base (left)		
D-50	M5 screw		

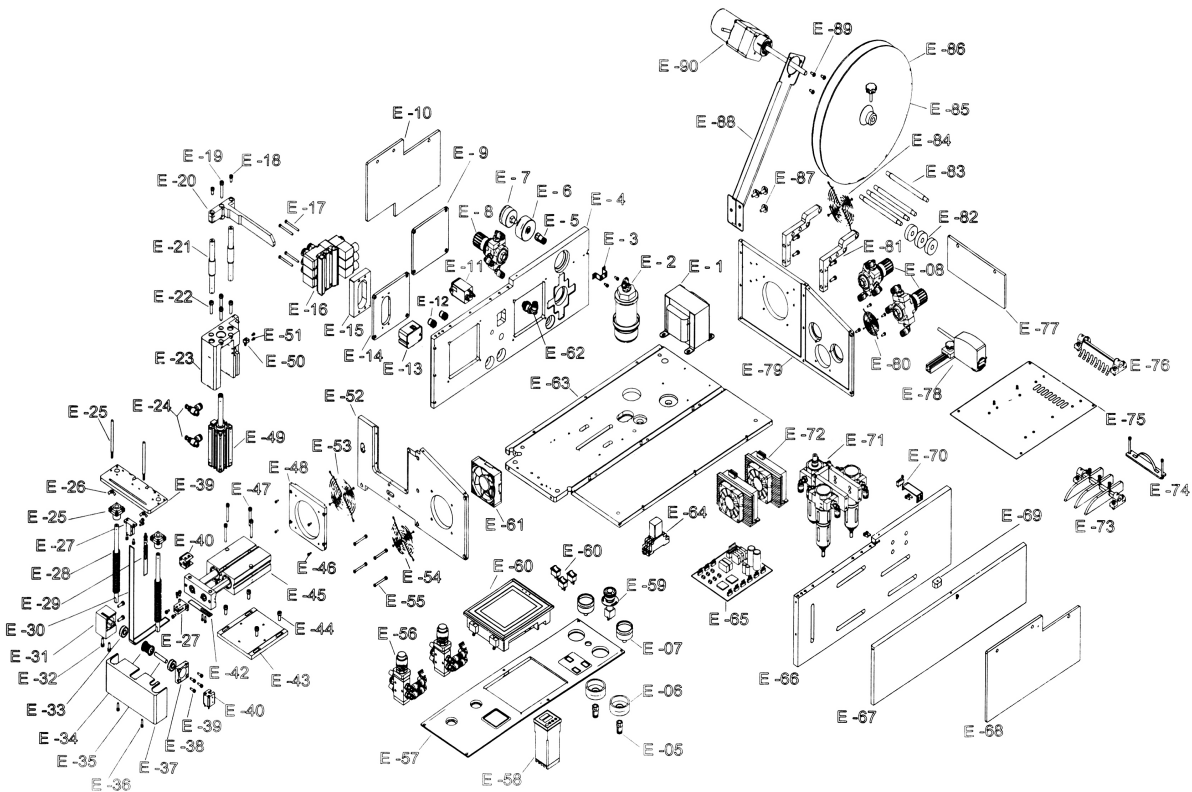

Fig. IV

Parts Drawing Fig. IV			
Drawing No.	Name	Drawing No.	Name
E-1	Transformer	E-51	M3 screw
E-2	Noise reducer	E-52	Front cover
E-3	Fixing plate of noise reducer	E-53	Filter screen
E-4	Left plate	E-54	Filter screen
E-5	Barometer joint	E-55	M4 screw
E-6	Fixing cover of barometer	E-56	Mechanical valve
E-7	Barometer	E-57	Panel
E-8	Pressure regulating valve	E-58	Temperature controller
E-9	Oil cap	E-59	Emergency stop switch
E-10	Organic glass left	E-60	Switch
E-11	Wave filter	E-61	Fan
E-12	Air plug	E-62	Air pipe joint
E-13	LED lamp	E-63	Base plate
E-14	Fixing plate of solenoid valve	E-64	Relay
E-15	Solenoid valve cushion	E-65	Circuit board
E-16	Solenoid valve + manifold block	E-66	Intermediate late
E-17	M4 screw	E-67	Right cover
E-18	M5 screw	E-68	Organic glass (right)
E-19	M6 screw	E-69	Fixed block of panel
E-20	Material pressing plate	E-70	Travel switch
E-21	Fixed axle of material pressing	E-71	Filter flask + oil bottle
E-22	M6 screw	E-72	Driver board
E-23	Fixed frame of material receiving cylinder	E-73	Material stopping plate
E-24	Throttle valve	E-74	Material flow pressing plate
E-25	Material stopping axle	E-75	Upper cover plate
E-26	Butterfly screw	E-76	Pressing plate
E-27	Fixed frame of material pressing belt	E-77	Organic glass (rear)
E-28	Material pressing compression spring	E-78	Color code sensor
E-29	Material pressing stop plate	E-79	Rear cover
E-30	Material pressing belt	E-80	Pressure regulating valve
E-31	Material pressing gear holder	E-81	Baffle plate block
E-32	M4 screw	E-82	Retaining ring
E-33	Bearing 628ZZ	E-83	Belt flow axle
E-34	Material pressing gear	E-84	Fan net
E-35	Material pressing gear shaft	E-85	Baffle disc
E-36	M4 screw	E-86	
E-37	Material pressing protective cover	E-87	M4 screw
E-38	Material pressing gear cover	E-88	Discharge arm of belt feeder
E-39	M4 screw	E-89	M5 screw
E-40	Sensor fixed frame, transverse	E-90	Belt-undoing motor
E-41	Fixed frame of sensor		
E-42	Baffle plate of material sensor		
E-43	Fixed frame of material receiving cylinder		
E-44	M5 screw		
E-45	Material receiving cylinder		
E-46	M4 screw		
E-47	M5 screw		
E-48	Filter screen frame		
E-49	Material pressing cylinder		
E-50	Trough type sensor		

台州市箭马缝纫机有限公司
TAIZHOU JEMA SEWING MACHINE CO.,LTD.

地址：浙江台州椒江下陈刘洋工业园区
ADD: Liuyang Industrial Zone, Xiachen, Jiaojiang,
Taizhou, Zhejiang, China

网址(Http): //www.chinajema.com
// www.中国切带机.com

邮箱(E-mail): jema@chinajema.com
电话(Tel): 0576-88172026 88157528
传真(FAX): 0576-88172167
邮编(P.C.): 318010