

**GT9820**

零件手册  
PARTS BOOK

---

零件手册  
PARTS BOOK



电脑圆头锁眼机  
ELECTRONIC EYELET BUTTON HOLER

---

## 型号牌的读解法

	切面线装置	切底线装置	
		长型	短型
-00	○	—	—
-01	○	○	—
-02	○	—	○

## Description of model plate

	Thread trimmer	Lower thread trimmer	
		Long type	Short type
-00	○	—	—
-01	○	○	—
-02	○	—	○

## 零件手册的使用说明

### 目 录

A. 机体部分 .....	1
B. 针杆·挑线杆装置 .....	5
C. 上轴装置 .....	9
D. 针摆装置 .....	11
E. 针杆摆动装置 .....	13
F1. 压脚装置 .....	15
F2. 压脚装置 .....	19
F3. 压脚装置 .....	21
G. 送布装置 .....	23
H. 切刀装置 .....	27
J. 下轴装置 .....	29
K. 弯针装置 .....	31
L. 双链式弯针装置 .....	33
M. 分纱装置 .....	37
N. 供油润滑装置 .....	39
P1. 穿线装置 .....	43
P2. 穿线装置 .....	47
P3. 穿线装置 .....	49
Q1. 切线装置 .....	51
Q2. 切线装置 .....	53
R. 面线剪切装置 .....	55
S1. 控制箱装置 .....	57
S2. 控制箱装置 (电源马达基板) .....	59
T. 开关装置 .....	61
U1. 空压装置 .....	63
U2. 空压装置 .....	65
V. 电气部品装置 .....	67
W. 操作盘装置 .....	69
X. 马达装置 .....	71
Y. 踏板开关关系 .....	73
AA1. 附属装置 .....	75
AA2. 附属装置 .....	81
AA3. 附属装置 .....	83
AA4. 附属装置 .....	85
AA5. 附属装置 .....	91
AA6. 附属装置 .....	95
Z. 附件 .....	97
Sp. 不同规格零部件一览表 .....	101
Wa. 警告标签 .....	104
索引 .....	105

## Notes for using this parts book

### CONTENTS

A. Machine body .....	1
B. Needle bar and thread take-up mechanism .....	5
C. Upper shaft mechanism .....	9
D. Zigzag mechanism .....	11
E. Needle bar rocking mechanism .....	13
F1. Presser foot mechanism .....	15
F2. Presser foot mechanism .....	19
F3. Presser foot mechanism .....	21
G. Feed mechanism .....	23
H. Cutter mechanism .....	27
J. Lower shaft mechanism .....	29
K. Looper mechanism .....	31
L. Double chain stitch looper mechanism .....	33
M. Spreader mechanism .....	37
N. Lubrication .....	39
P1. Threading mechanism .....	43
P2. Threading mechanism .....	47
P3. Threading mechanism .....	49
Q1. Thread trimmer mechanism .....	51
Q2. Thread trimmer mechanism .....	53
R. Upper thread trimmer mechanism .....	55
S1. Control box mechanism .....	57
S2. Control box mechanism (Power supply motor PCB) .....	59
T. Power switch mechanism .....	61
U1. Air pressure mechanism .....	63
U2. Air pressure mechanism .....	65
V. Power supply equipment mechanism .....	67
W. Operation panel mechanism .....	69
X. Motor mechanism .....	71
Y. Foot switch pedal mechanism .....	73
AA1. Attachment set .....	75
AA2. Attachment set .....	81
AA3. Attachment set .....	83
AA4. Attachment set .....	85
AA5. Attachment set .....	91
AA6. Attachment set .....	95
Z. Accessories .....	97
Sp. Different parts list .....	101
Wa. Warning labels .....	104
Index .....	105



A. 机体部分 / Machine body

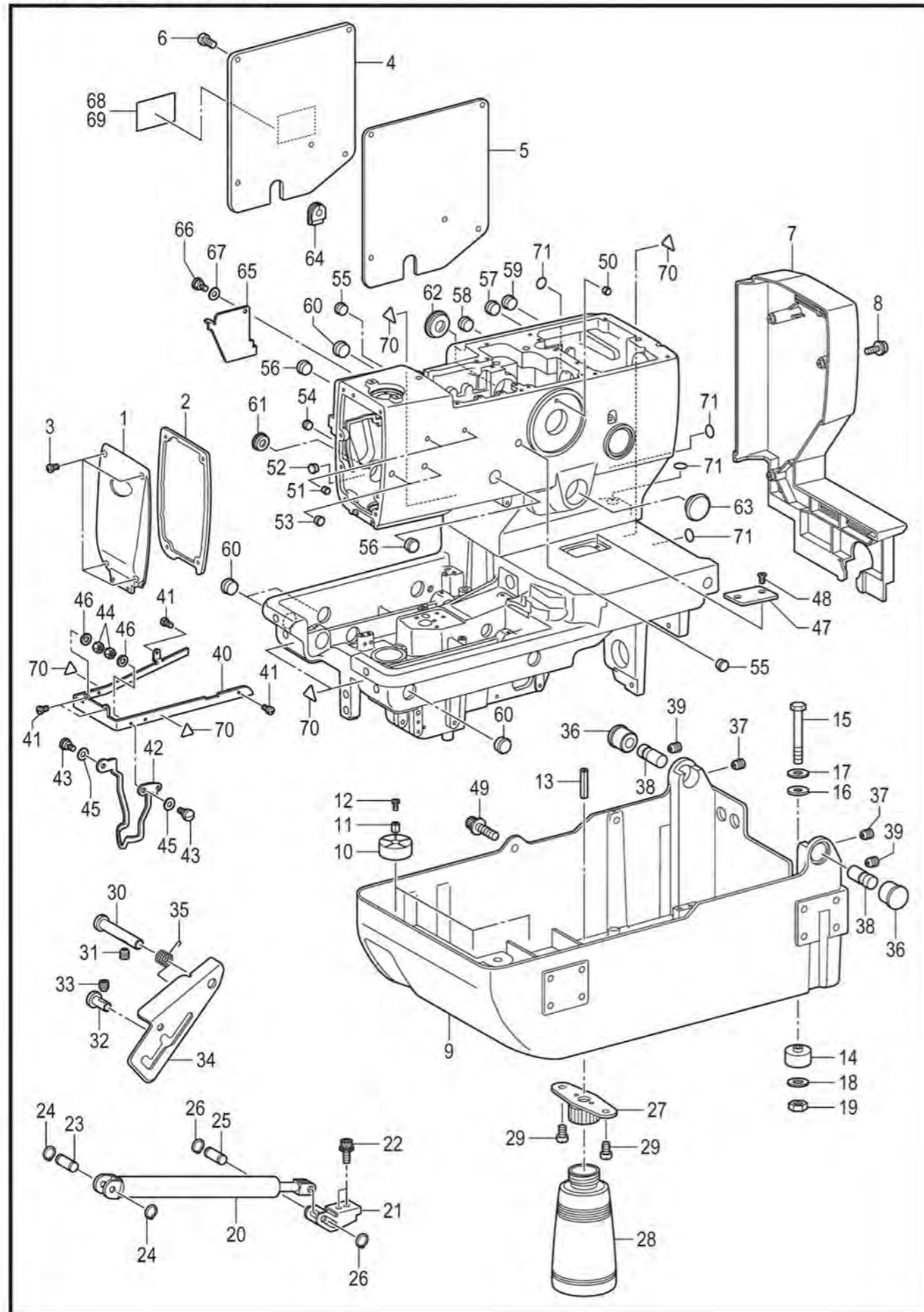

A. 机体部分 / Machine body

参照号	零部件序号	数量	零部件名称	NAME OF PARTS	RM
1	CSA5746001	1	主面板	MAIN PLATE	
2	CSA5747001	1	主面板垫片	MAIN PLATE PACKING	
3	C 062501216	4	螺钉 M5X12	SCREW PAN M5X12	
4	CSA5749001	1	侧板	REAR COVER	
5	CSA5750001	1	侧板垫片	REAR COVER PACKING	
6	C 062501216	5	螺钉 M5X12	SCREW PAN M5X12	
7	CSA5751001	1	皮带罩	BELT COVER	
8	C0A4401606	4	螺栓(带垫圈) M4X16DA	SCREW PAN (S/P WASHER) M4X16	
9	CSA5752201	1	底板台	BED BASE	
10	CSA5753001	3	底座防震垫	BED BASE CUSHION	
11	CSA7556001	3	垫块 4X6.5	SPACER 4X6.5	
12	C060401216	3	螺钉 M4X12	SCREW BIND M4X12	
13	C047502242	1	弹簧销 AW5	PIN SPRING ROLL AW5	
14	C 158827009	4	底座防震垫 A	BED BASE CUSHION, A	
15	CS21728001	4	螺栓 M6X80	BOLT M6X80	
16	C 159458009	4	橡皮垫	RUBBER SHEET	
17	C 115947101	4	垫圈 6.35	WASHER PLAIN 6.35	
18	C025060336	4	平垫圈 L6	WASHER PLAIN L 6	
19	C021060106	4	螺母 M6	NUT 1 M6	
20	CSA5754001	1	缓冲器	GS SPRING	
21	CSA5763001	1	GS支撑板	GS SUPPORT PLATE	
22	CS55477001	2	螺栓(带垫圈) M6X16	BOLT SOCKET (S/P WASHER)M6X16	
23	CS35218101	1	GS销 F	SUPPORT PIN, F :GS	
24	C048080142	2	轴用挡圈 C8	RETAINING RING EXTERNAL C8	
25	CSA5764001	1	GS支撑轴	GS SUPPORT SHAFT	
26	C048080142	2	轴用挡圈 C8	RETAINING RING EXTERNAL C8	
27	C 154465001	1	废油盖支撑组件	DUST OILER SUPPORT ASSY	
28	C 114486002	1	油壶	OILER	
29	C 062500816	2	螺钉 M5X8	SCREW PAN M5X8	
30	CSA5765101	1	铰链杆轴	HINGE LEVER SHAFT	
31	C014060836	1	固定螺钉 M6X8	SET SCREW SOCKET (CP) M6X8	
32	CSA5766001	1	铰链支撑轴	HINGE SUPPORT SHAFT	
33	C014060836	1	固定螺钉 M6X8	SET SCREW SOCKET (CP) M6X8	
34	CSA5791101	1	头部支撑手柄	HEAD SUPPORT LEVER	
35	CSA5792001	1	弹簧 A	SPRING TWIST A	
36	CSA5802001	2	铰链 B	HINGE B	
37	C014060836	2	固定螺钉 M6X8	SET SCREW SOCKET (CP) M6X8	
38	CSA7044001	2	底板铰链轴	BED HINGE SHAFT	
39	C014060836	2	固定螺钉 M6X8	SET SCREW SOCKET (CP) M6X8	
40	CSA5803001	1	针导向盖	NEEDLE GUIDE COVER	
41	C 062400816	4	螺钉 M4X8	SCREW PAN M4X8	
42	CSA5804001	1	护指器	FINGER GUARD	
43	CS35221101	2	段螺钉 M4	SHOULDER SCREW M4	
44	C021400206	2	六角螺母 M4	NUT 2 M4	
45	C 107017001	2	弹簧垫圈	WAVE WASHER	
46	C028040246	2	弹簧垫圈 2-4	WASHER SPRING 2-4	
47	CSA5805001	1	底板盖	BED COVER	
48	C004401003	2	螺钉 M4X10	SCREW, FLAT M4X10	
49	CS58636001	1	螺栓(带垫圈) M8X30	BOLT SOCKET (S/P WASHER)M8X30	
50	C 104833001	1	橡皮塞 4.3	RUBBER CAP, 4.3	
51	C 104833001	2	橡皮塞 4.3	RUBBER CAP, 4.3	
52	CS32263001	1	橡皮塞 8.5	RUBBER CAP, 8.5	
53	CS32263001	2	橡皮塞 8.5	RUBBER CAP, 8.5	
54	CS32263001	1	橡皮塞 8.5	RUBBER CAP, 8.5	
55	C 104821001	2	橡皮塞 10.5	RUBBER CAP, 10.5	
56	C 150756000	2	橡皮塞 18.5	RUBBER CAP, 18.5	
57	C 150756000	1	橡皮塞 18.5	RUBBER CAP, 18.5	
58	C 150756000	1	橡皮塞 18.5	RUBBER CAP, 18.5	
59	C 150756000	1	橡皮塞 18.5	RUBBER CAP, 18.5	
60	C 158882001	4	橡皮塞 22	RUBBER CAP, 22	
61	CSA5810001	1	橡皮塞 23.5	RUBBER CAP 23.5	
62	CSA5811001	1	橡皮塞 38.5	RUBBER CAP 38.5	



A. 机体部分 / Machine body

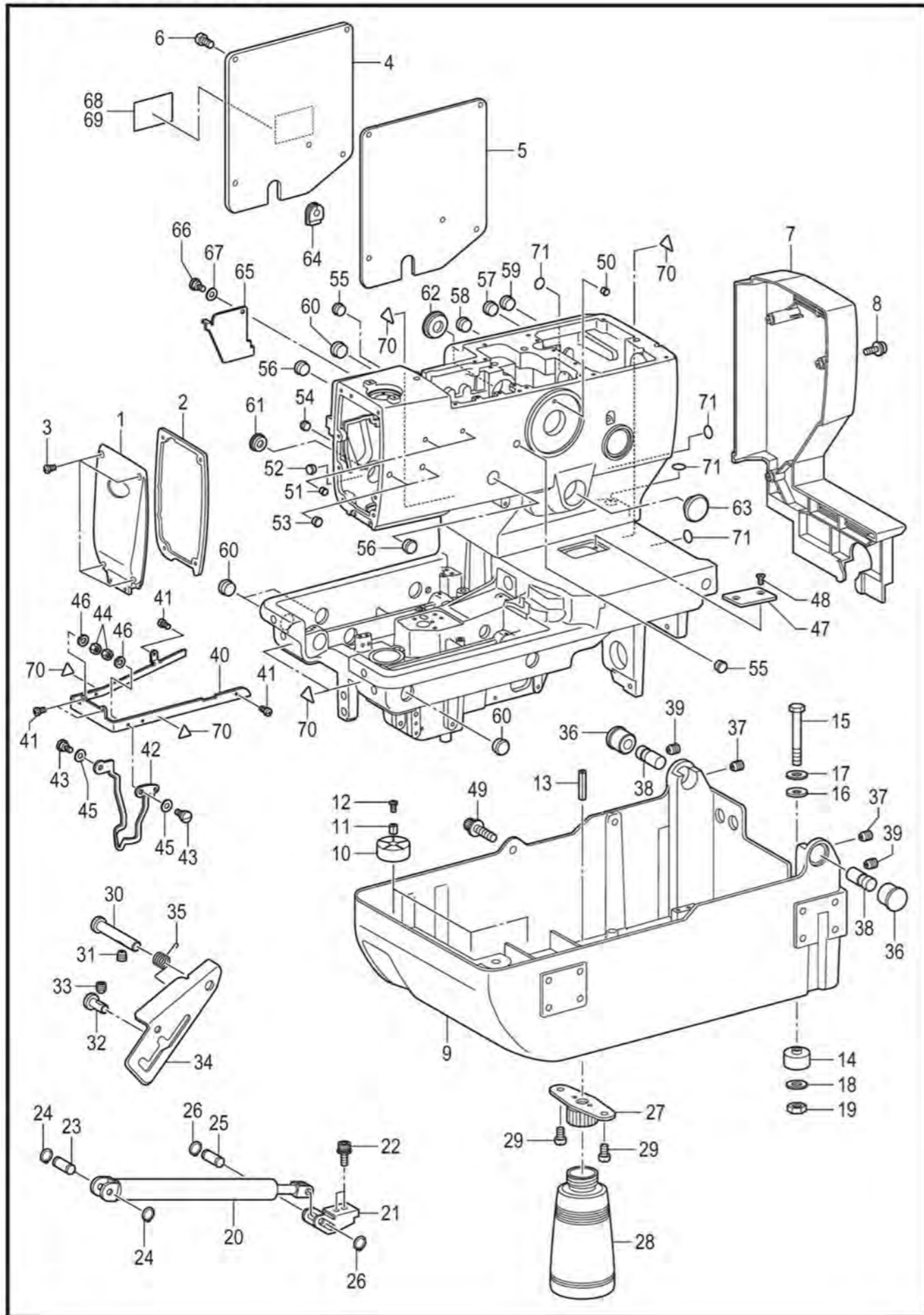

A. 机体部分 / Machine body

参照号	零部件序号	数量	零部件名称	NAME OF PARTS	RM
63	CSA5819001	1	橡皮塞	RUBBER CAP	
64	CSA5820001	1	线管	CORD BUSH	
65	CSA5821001	1	窗盖	Z-WINDOW COVER	
66	CS35221101	1	段螺钉 M4	SHOULDER SCREW M4	
67	C107017001	1	弹簧垫圈	WAVE WASHER	
			<用于日本以外>	<Except for Japan>	
68	CSA0793001	1	操作注意标签(中/英)	LABEL, CAUTION CHN/ENG	
			<用于日本>	<For Japan only>	
69	CSA0792001	1	操作注意标签(日/英)	LABEL, CAUTION JPN/ENG	
70	CS36924001	6	警告标记	INJURY MARK	
71	CS37060001	4	接地标记	LABEL, GROUNDING	



B. 针杆·挑线杆装置 / Needle bar and thread take-up mechanism

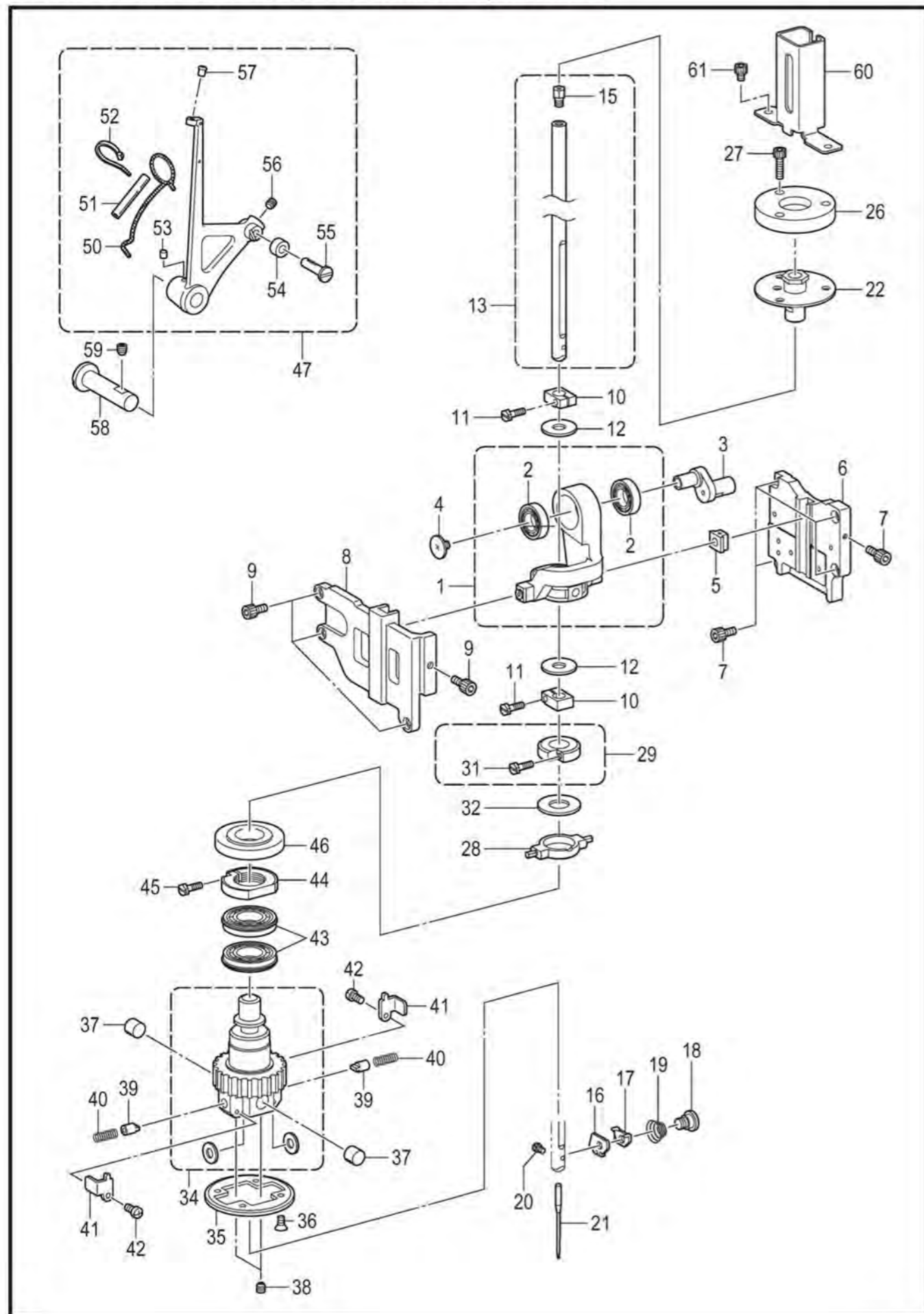

B. 针杆·挑线杆装置 / Needle bar and thread take-up mechanism

参照号	零部件序号	数量	零部件名称	NAME OF PARTS	RM
1	CSA5936001	1	曲柄连杆总组件	CRANK ROD UNIT	
2	CSA5570001	2	轴承 608ZZ	BALL BEARING 608ZZ	
3	CSA6652001	1	针杆曲柄	NEEDLE BAR CRANK	
4	C 145465001	1	螺钉 SM3.57-40X6L	SCREW, SM3.57-40X6 L	
5	CSA6653001	1	滑块 8X10D	SLIDE BLOCK 8X10D	
6	CSA6654101	1	滑块导向 D	SLIDE BLOCK GUIDE D	
7	C018401036	5	螺栓 M4X10	BOLT SOCKET M4X10	
8	CSA6655001	1	滑块导向 F	SLIDE BLOCK GUIDE F	
9	C018401036	4	螺栓 M4X10	BOLT SOCKET M4X10	
10	CS35332001	2	针杆抱箍	NEEDLE BAR CLAMP	
11	CS59242001	2	固定螺钉	NEEDLE BAR BRACKET SCREW	
12	CSA6656001	2	垫圈 8X21X1.5	WASHER 8X21X1.5	
13	CSA6657001	1	针杆组件 L	NEEDLE BAR ASSY L	
15	CSA6659001	1	针杆线口 S	NEEDLE BAR YARN FEEDER S	
16	CS41310101	1	线导向 A	NEEDLE GUIDE, A	
17	CS41251101	1	压线板 A	NEEDLE THREAD HOLDER PLATE, A	
18	C 141514002	1	段螺钉 SM3.18	SHOULDER SCREW, SM3.18	
19	CS35118101	1	调整弹簧	TENSION SPRING	
20	C 140553102	1	固定螺钉 SM3.18	SET SCREW, SM3.18	
21	CSA4857016	1	<用于-00> 机针 DOX558-NY2 (#16)	<For -00> NEEDLE, DO x 558-NY2 (#16)	
21	CSA4857014	1	<用于-01> 机针 DOX558-NY2 (#14)	<For -01> NEEDLE, DO x 558-NY2 (#14)	
21	CSA4857018	1	<用于-02> 机针 DOX558-NY2 (#18)	<For -02> NEEDLE, DO x 558-NY2 (#18)	
21	CS35133016	1	<用于-00> 机针 DOX558 (#16)	<For -00> NEEDLE, DO x 558 (#16)	
21	CS35133014	1	<用于-01> 机针 DOX558 (#14)	<For -01> NEEDLE, DO x 558 (#14)	
21	CS35133018	1	<用于-02> 机针 DOX558 (#18)	<For -02> NEEDLE, DO x 558 (#18)	
22	CSA5830001	1	针杆轴套组件 U	NEEDLE BAR BUSH U ASSY	
26	CSA5833001	1	针杆轴套支撑基座 C	NEEDLE BAR BUSH HOLDER BASE C	
27	C018402036	3	螺栓 M4X20	BOLT SOCKET M4X20	
28	CSA5834001	1	针摆水平连杆	ZIGZAG HORIZON LINK	
29	CSA5835001	1	针杆支架组件	NEEDLE BAR BLOCK BRACKET ASSY	
31	CS59242001	1	固定螺钉	NEEDLE BAR BRACKET SCREW	
32	CS35113001	1	针杆管套	NEEDLE BAR BLOCK COLLAR	
34	CSA5837001	1	针杆齿轮基座组件	NEEDLE BAR GUAND BLOCK ASSY	
35	CSA7609001	1	手轮法兰	PULLEY FLANGE	
36	CS06696004	4	螺钉 M3X6	SCREW, FLAT M3X6	
37	CSA5907001	2	针杆导向管套	NEEDLE BAR GUIDE COLLAR	
38	C 014400532	2	螺钉 M4X5	SET SCREW SOCKET (CP) M4X5	
39	CS35137001	2	针杆导向	NEEDLE BAR GUIDE	
40	CS35136001	2	弹簧	NEEDLE BAR GUIDE SPRING	
41	CSA5908001	2	针杆导向支撑板	NEEDLE BAR GUIDE SUPPORT PLATE	
42	C062300616	2	螺钉 M3X6	SCREW PAN M3X6	
43	CSA5919001	2	轴承 6805ZZNR	BALL BEARING 6805ZZNR	
44	CSA5920001	1	针杆齿轮螺母	NEEDLE BAR GUARD NUT	
45	CS59242001	1	固定螺钉	NEEDLE BAR BRACKET SCREW	
46	CSA5923001	1	齿轮螺母盖	GEAR NUT COVER	
47	CSA7531001	1	挑线杆总组件	THREAD TAKE-UP LEVER UNIT	
50	CSA5843001	1	油线 2X2	WICK 2X2	
51	CSA5849001	1	油管	OIL TUBE	
52	C228475000	1	电线夹 1.9X80	FASTENING BAND 1.9X80	
53	CS25328001	1	油毡	FELT	
54	CSA5850001	1	滚轮	ROLLER	
55	CSA5865001	1	滚轮轴	ROLLER SHAFT	
56	C012500536	1	螺钉 M5X5	SET SCREW SOCKET (FT) M5X5	
57	CSA5842001	1	线导向	THREAD GUIDE	



B. 针杆·挑线杆装置 / Needle bar and thread take-up mechanism

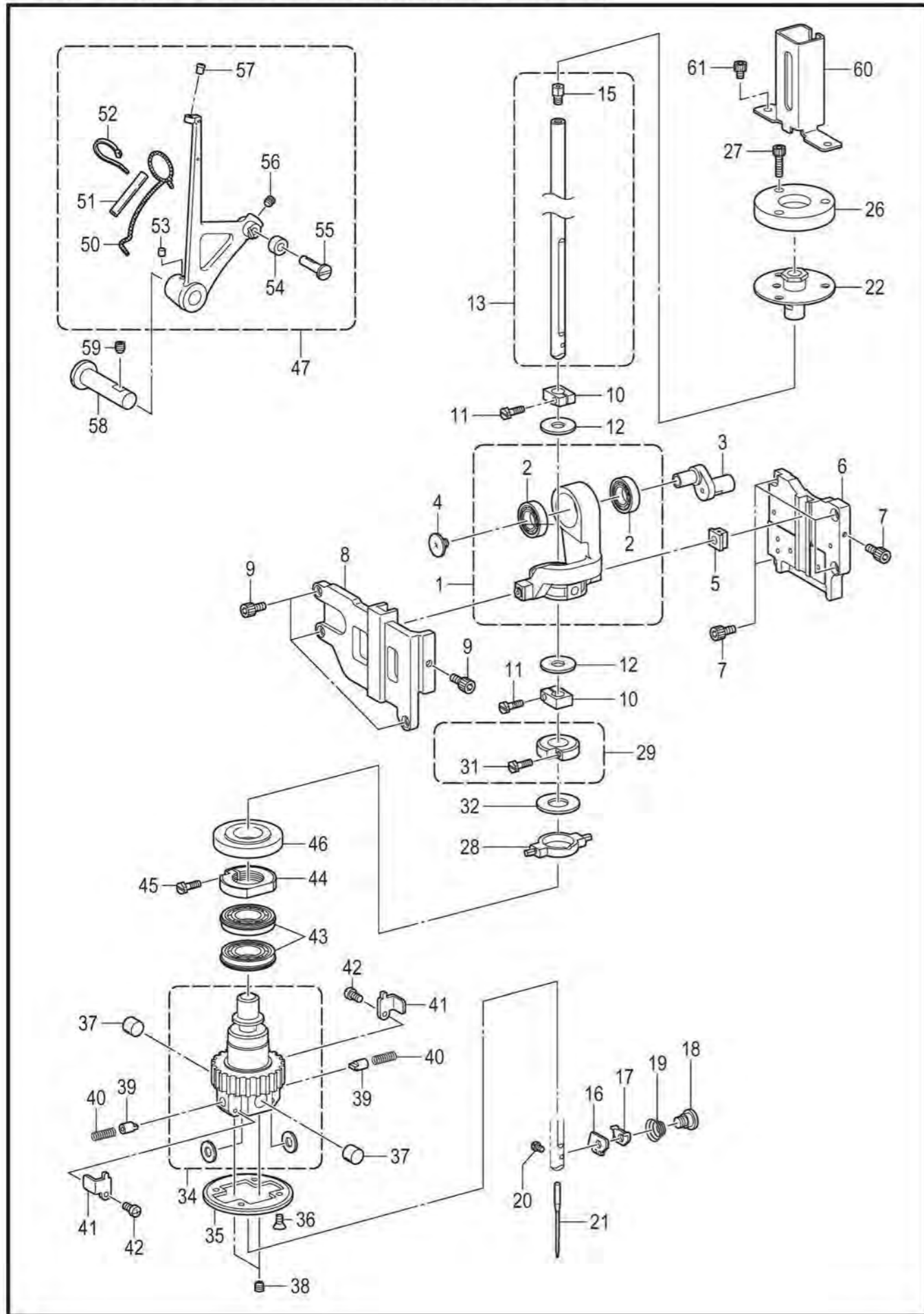

B. 针杆·挑线杆装置 / Needle bar and thread take-up mechanism

参照号	零部件序号	数量	零部件名称	NAME OF PARTS	RM
58	CSA5880001	1	挑线杆支撑轴	THREAD TAKE-UP L SUPPORT SHAFT	
59	C014060636	1	固定螺钉 M6X6	SET SCREW SOCKET (CP) M6X6	
60	CSA5889001	1	针杆护架	NEEDLE BAR GUARD	
61	C018400636	2	螺栓 M4X6	BOLT SOCKET M4X6	

C. 上轴装置 / Upper shaft mechanism

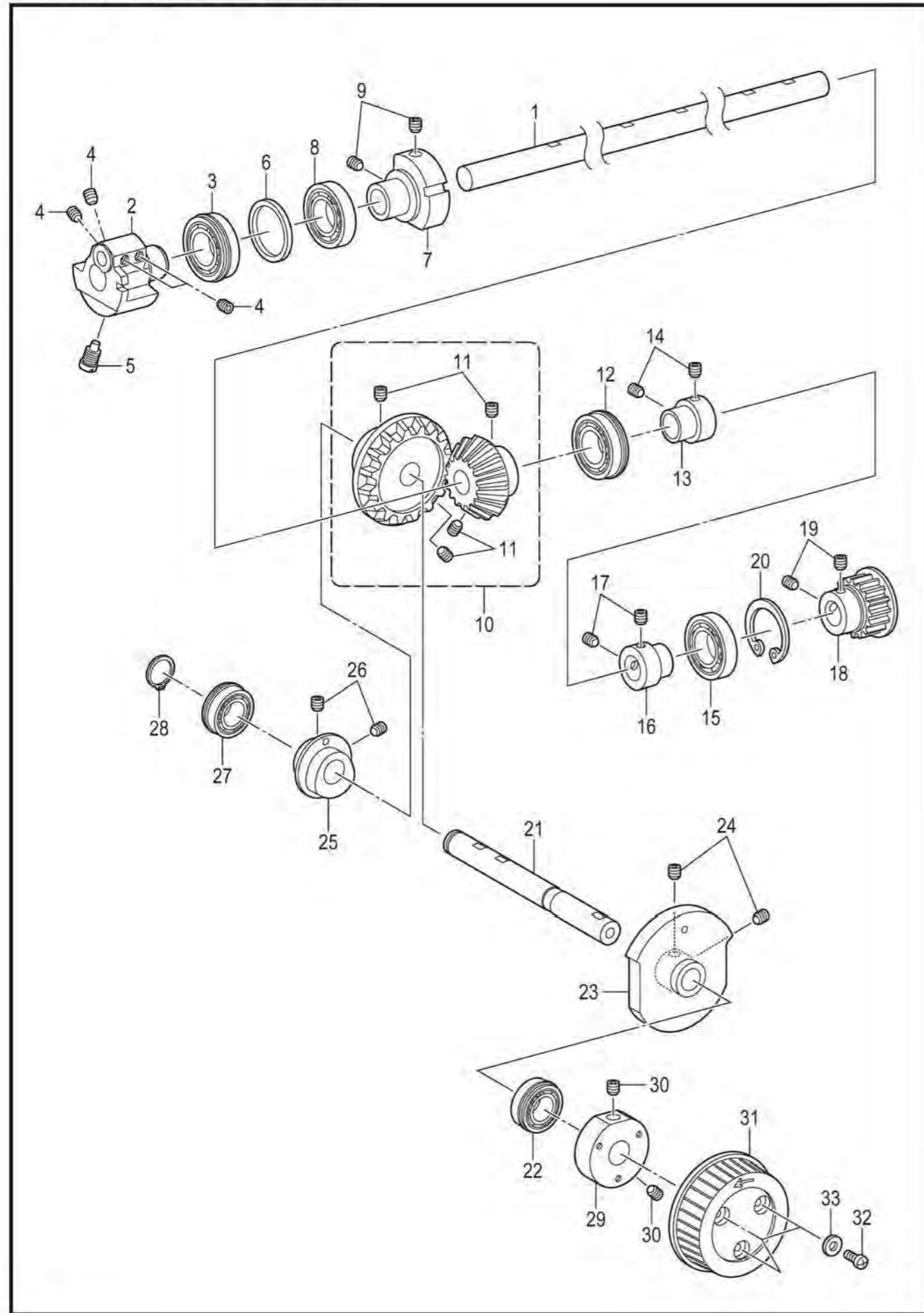

C. 上轴装置 / Upper shaft mechanism

参照号	零部件序号	数量	零部件名称	NAME OF PARTS	RM
1	CSA5890001	1	上轴	UPPER SHAFT	
2	CSA5893001	1	上轴曲柄	UPPER SHAFT CRANK	
3	CSA5571001	1	轴承 6004ZZNR	BALL BEARING 6004ZZNR	
4	CS23651001	4	固定螺钉 M6X6	SET SCREW SOCKET (FT) M6X6	
5	CS25235001	1	螺钉 M8	SCREW M8	
6	CSA5897001	1	垫圈 34X42	SPACER 34X42	
7	CSA6661001	1	平衡管套	BALANCE COLLAR	
8	CSA5572001	1	轴承 6004ZZ	BALL BEARING 6004ZZ	
9	CS23651001	2	固定螺钉 M6X6	SET SCREW SOCKET (FT) M6X6	
10	CSA6662001	1	伞齿轮组件	HYPOID GEAR ASSY	
11	CS23651001	4	固定螺钉 M6X6	SET SCREW SOCKET (FT) M6X6	
12	CSA5573001	1	轴承 6204ZZNR	BALL BEARING 6204ZZNR	
13	CSA5564001	1	轴承管套	BEARING COLLAR	
14	CS23651001	2	固定螺钉 M6X6	SET SCREW SOCKET (FT) M6X6	
15	CSA6667001	1	轴承 6304ZZ	BALL BEARING 6304ZZ	
16	CSA5564001	1	轴承管套	BEARING COLLAR	
17	CS23651001	2	固定螺钉 M6X6	SET SCREW SOCKET (FT) M6X6	
18	CSA5549001	1	同步手轮组件	TIMING PULLEY ASSY	
19	CS23651001	2	固定螺钉 M6X6	SET SCREW SOCKET (FT) M6X6	
20	C048520242	1	孔用挡圈 C52	RETAINING RING INTERNAL C52	
21	CSA6668001	1	轴	ORTHOGONAL SHAFT	
22	CSA6669001	1	轴承 6202DDUNR	BALL BEARING 6202DDUNR	
23	CSA6671001	1	挑线杆凸轮	CAM ROLLER TAKE-UP	
24	CS23651001	2	固定螺钉 M6X6	SET SCREW SOCKET (FT) M6X6	
25	CSA6673001	1	针摆凸轮	ZIGZAG CAM	
26	CS23651001	2	固定螺钉 M6X6	SET SCREW SOCKET (FT) M6X6	
27	CSA6674001	1	轴承 6002ZZNR	BALL BEARING 6002ZZNR	
28	C048150142	1	轴用挡圈 C15	RETAINING RING EXTERNAL C15	
29	CSA4629001	1	上轮基座	PULLEY BASE	
30	CS23651001	2	固定螺钉 M6X6	SET SCREW SOCKET (FT) M6X6	
31	CSA6676001	1	手轮	PULLEY	
32	C062401016	3	螺钉 M4X10	SCREW PAN M4X10	
33	CSA5158101	3	垫圈 L4	WASHER PLAIN L 4	



D. 针摆装置 / Zigzag mechanism

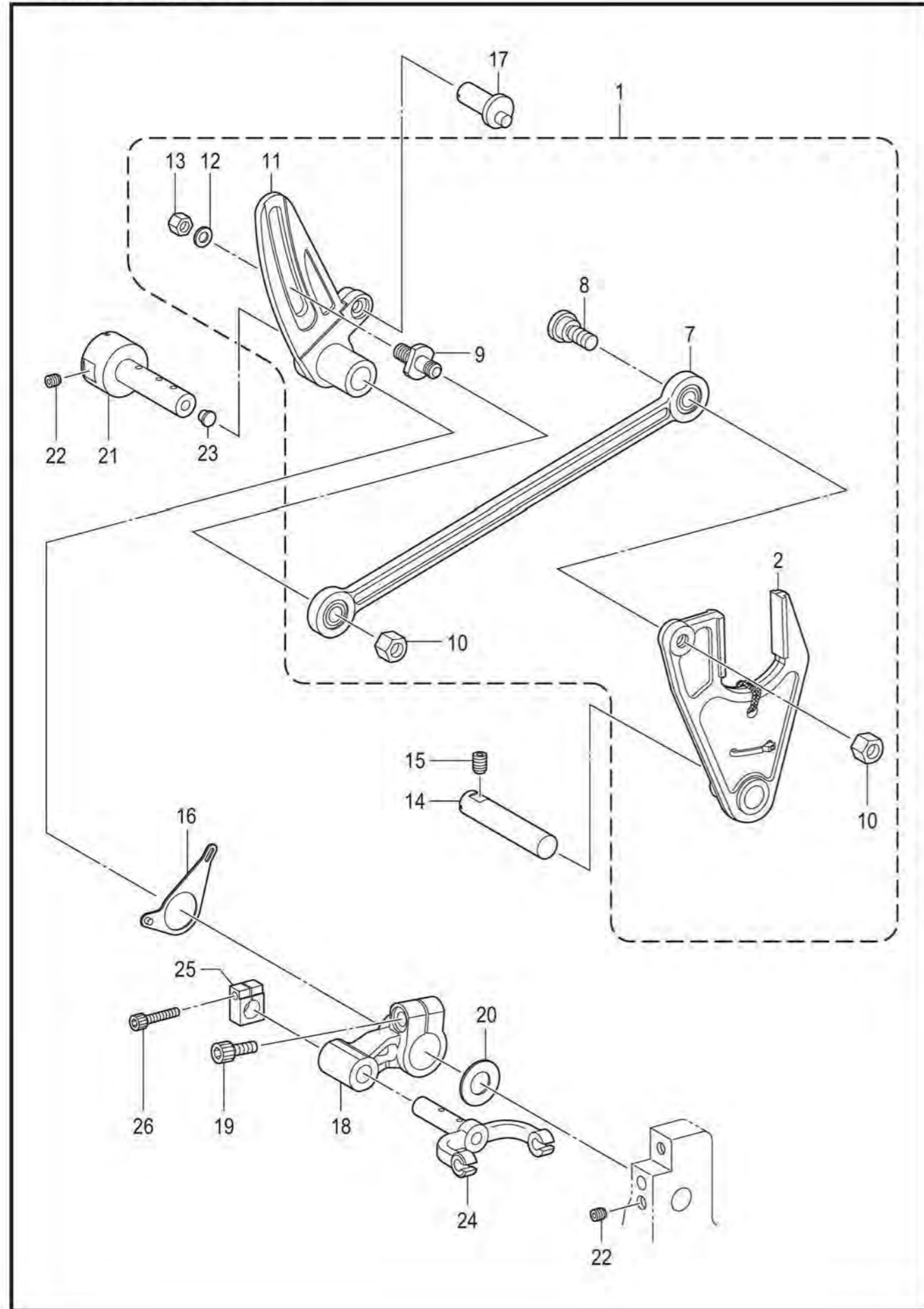

D. 针摆装置 / Zigzag mechanism

参照号	零部件序号	数量	零部件名称	NAME OF PARTS	RM
1	CSA6677001	1	针摆复合件	ZIGZAG UNIT	
2	CSA6678001	1	针摆叉组件	ZIGZAG FORK ASSY	
7	CSA6682001	1	针摆连杆组件	ZIGZAG CONNECTING ROD ASSY	
8	CSA6684001	1	段螺钉 M6	SHOULDER SCREW M6	
9	CSA6685001	1	双头螺栓	ZIGZAG CRANK SCREW	
10	C021060106	2	螺母 M6	NUT 1 M6	
11	CSA6686001	1	针摆曲柄	ZIGZAG CRANK	
12	C155559001	1	平垫圈	WASHER PLAIN	
13	CS35251101	1	螺母 M6	NUT M6	
14	CSA6687001	1	针摆叉轴	ZIGZAG FORK SUPPORT SHAFT	
15	C012061036	1	螺钉 M6X10	SET SCREW SOCKET (FT) M6X10	
16	CSA6688001	1	针位调整板组件	N-POSITION CONTROL PLATE ASSY	
17	CS35252001	1	针摆偏心销	Z-ECCENTRIC PIN	
18	CSA6691001	1	针摆驱动杆	ZIGZAG DRIVING LEVER	
19	C018061636	1	螺栓 M6X16	BOLT SOCKET M6X16	
20	CSA6692001	1	垫圈	SPACER	
21	CSA6693001	1	针摆动轴	ZIGZAG COAXIAL ROCK SHAFT	
22	C012500536	2	螺钉 M5X5	SET SCREW SOCKET (FT) M5X5	
23	C156482000	1	橡皮塞 4	CAP, 4	
24	CSA6694001	1	针摆臂	ZIGZAG LEVER	
25	CS35332001	1	针杆抱箍	NEEDLE BAR CLAMP	
26	C018301236	1	螺栓 M3X12	BOLT SOCKET M3X12	

E. 针杆摆动装置 / Needle bar rocking mechanism

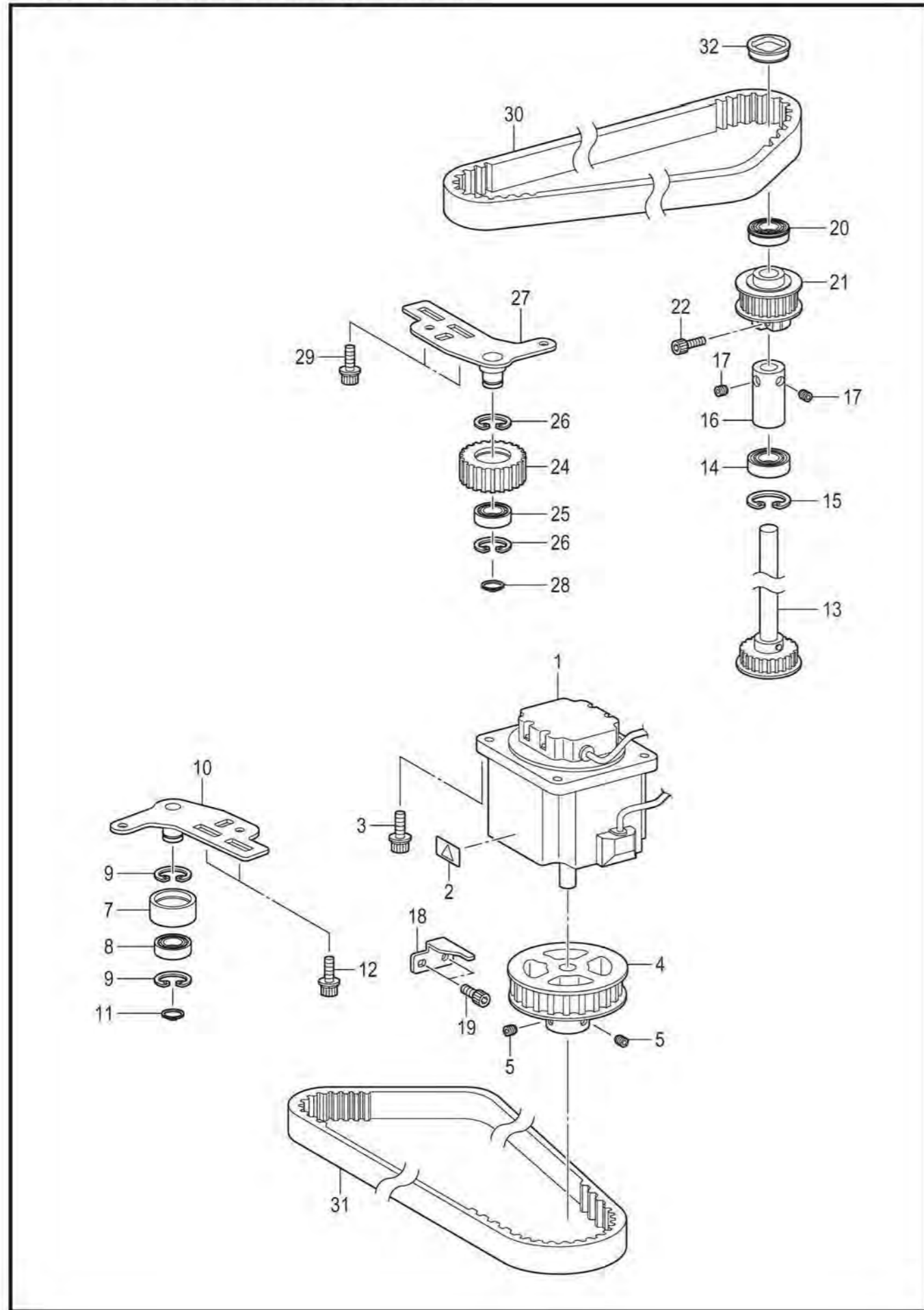

E. 针杆摆动装置 / Needle bar rocking mechanism

参照号	零部件序号	数量	零部件名称	NAME OF PARTS	RM
1	CSA6542001	1	脉冲马达组件 R	PULSE MOTOR ASSY R	
2	CJ03663001	1	高温标签 13X20	LABEL, HIGH TEMP. 13X20	
3	CS55487001	4	螺栓(带垫圈) 5X16	BOLT SOCKET (S/P WASHER)M5X16	
4	CSA6695001	1	送布轮组件 M	THETA M PULLEY ASSY	
5	C012060636	2	螺钉 M6X6	SET SCREW SOCKET (FT) M6X6	
7	CS35284101	1	张力轮	TENSION PULLEY	
8	CSA5574001	1	轴承 6000ZZ	BALL BEARING 6000ZZ	
9	C048260242	2	孔用挡圈 C26	RETAINING RING INTERNAL C26	
10	CSA5552001	1	支架组件	T PULLEY HOLDER ASSY	
11	C048100142	1	轴用挡圈 C10	RETAINING RING EXTERNAL C10	
12	CS55481001	2	螺栓(带垫圈) M4X12	BOLT SOCKET (S/P WASHER)M4X12	
13	CSA6699001	1	弯针移动轴组件	DRIVING LOOPER SHAFT ASSY	
14	CSA6702001	1	轴承 6201ZZ	BALL BEARING 6201ZZ	
15	C048320242	1	孔用挡圈 C32	RETAINING RING INTERNAL C32	
16	CSA6703001	1	紧圈	SET SCREW COLLAR	
17	C012060636	2	螺钉 M6X6	SET SCREW SOCKET (FT) M6X6	
18	CSA6704001	1	马达定位	MOTOR STOPPER	
19	C018061236	2	螺栓 M6X12	BOLT SOCKET M6X12	
20	CSA6705001	1	轴承 6001ZZNR	BALL BEARING 6001ZZNR	
21	CSA6707001	1	竖轴张力轮组件 U	V-PULLEY T-PULLEY U ASSY	
22	C018401636	1	螺栓 M4X16	BOLT SOCKET M4X16	
24	CSA6711001	1	张力轮 U	TENSION PULLEY U	
25	CSA5574001	1	轴承 6000ZZ	BALL BEARING 6000ZZ	
26	C048260242	2	孔用挡圈 C26	RETAINING RING INTERNAL C26	
27	CSA5552001	1	支架组件	T PULLEY HOLDER ASSY	
28	C048100142	1	轴用挡圈 C10	RETAINING RING EXTERNAL C10	
29	CS55481001	2	螺栓(带垫圈) M4X12	BOLT SOCKET (S/P WASHER)M4X12	
30	CSA6712001	1	T皮带 580-5GT	T BELT 580-5GT	
31	CSA6713001	1	T皮带 810-5GT	T BELT 810-5GT	
32	CSA6714001	1	橡皮塞 32.5	RUBBER CAP 32.5	



F1. 压脚装置 / Presser foot mechanism

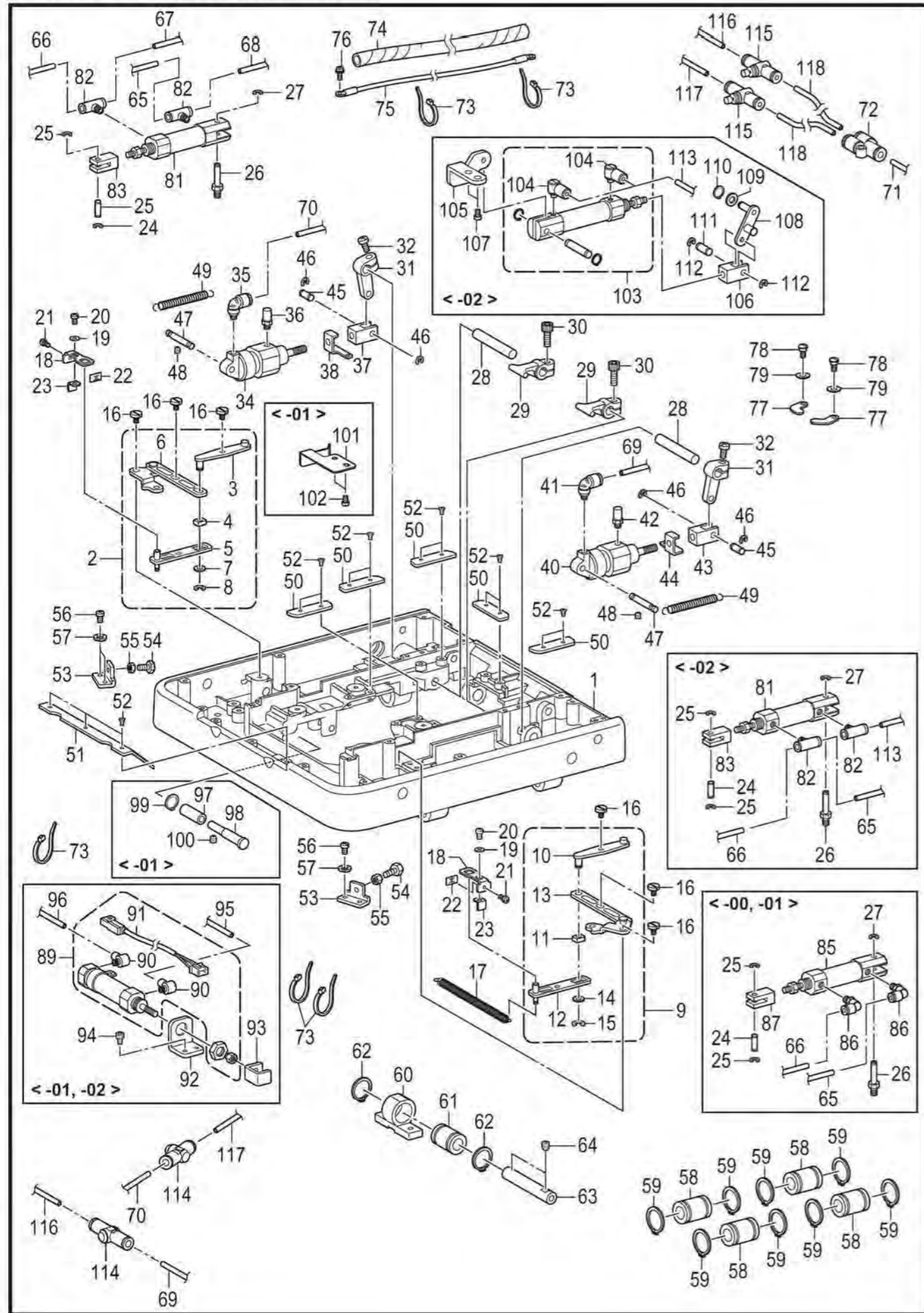

F1. 压脚装置 / Presser foot mechanism

参照号	零部件序号	数量	零部件名称	NAME OF PARTS	RM
			<用于-00, -01和-02>	<For -00, -01 & -02>	
1	CSA5690001	1	送布台	FEED BAR	
2	CSA5677001	1	打开连杆组件 L	OPENING CONNECTING ROD ASSY L	
3	CSA7176001	1	支点杆板	FULCRUM LEVER PLATE	
4	C102630001	1	针杆接头滑块	NEEDLE BAR GUIDE SLIDE BLOCK	
5	CSA5557001	1	摇动杆	ROCKER LEVER	
6	CSA5579001	1	打开驱动杆组件 L	OPENING DRIVING LEVER ASSY L	
7	C109763002	1	垫圈	WASHER	
8	C048050342	1	挡圈 E5	RETAINING RING E5	
9	CSA5678001	1	打开连杆组件 R	OPENING CONNECTING ROD ASSY R	
10	CSA7176001	1	支点杆板	FULCRUM LEVER PLATE	
11	C102630001	1	针杆接头滑块	NEEDLE BAR GUIDE SLIDE BLOCK	
12	CSA5557001	1	摇动杆	ROCKER LEVER	
13	CSA5578001	1	打开驱动杆组件 R	OPENING DRIVING LEVER ASSY R	
14	C109763002	1	垫圈	WASHER	
15	C048050342	1	挡圈 E5	RETAINING RING E5	
16	CSA7527001	6	段螺钉 M5	SHOULDER SCREW M5	
17	CS35429101	1	弹簧	EXTENSION SPRING	
18	CSA5583001	2	定位板	STOPPER PLATE OPENING	
19	C026040236	2	平垫圈 M4	WASHER PLAIN M4	
20	C062400816	2	螺钉 M4X8	SCREW PAN M4X8	
21	C062301016	2	螺钉 M3X10	SCREW PAN M3X10	
22	CS34968000	2	螺母 M3	SPEED NUT M3	
23	CS35328001	2	定位板	STOPPER PLATE	
24	CS34969001	2	气缸连杆销 B	ROD PIN, B :CYLINDER	
25	C048030342	4	挡圈 E3	RETAINING RING E3	
26	CSA5584001	2	气缸螺栓	CYLINDER SCREW	
27	C048050142	2	轴用挡圈 C5	RETAINING RING EXTERNAL C5	
28	CS35239101	2	压脚杆轴	CLAMP LEVER SHAFT	
29	CS35240001	2	压脚杆 B	CLAMP LEVER, B	
30	C018501236	2	螺栓 M5X12	BOLT SOCKET M5X12	
31	CSA5582001	2	压脚驱动杆	CLAMP DRIVING LEVER	
32	C062501202	2	螺钉 M5X12	SCREW PAN M5X12	
34	CS35350000	1	气缸 16X10	CYLINDER 16X10	
35	CS53488000	1	接头	JOINT	
36	CS13955000	1	消音器	AIR BOLSTER	
37	CSA5558001	1	气缸连杆	CLAMP CYLINDER ROD	
38	CS35457001	1	弹簧挂钩 L	SPRING HOOK, L	
40	CS35350000	1	气缸 16X10	CYLINDER 16X10	
41	CS53488000	1	接头	JOINT	
42	CS13955000	1	消音器	AIR BOLSTER	
43	CSA5558001	1	气缸连杆	CLAMP CYLINDER ROD	
44	CS35458001	1	弹簧挂钩 R	SPRING HOOK, R	
45	CS35305001	2	气缸连杆销	CYLINDER ROD PIN	
46	C048030342	4	挡圈 E3	RETAINING RING E3	
47	CS35304001	2	气缸支架杆	CLAMP CYLINDER SUPPORT	
48	C014400532	2	螺钉 M4X5	SET SCREW SOCKET (CP) M4X5	
49	CS35456101	2	弹簧	SPRING	
50	CSA5675001	5	导向板 A	GUIDE PLATE A	
51	CSA5676001	1	导向板 B	GUIDE PLATE B	
52	CS06696004	13	螺钉 M3X6	SCREW, FLAT M3X6	
53	CS35327001	2	气缸定位	OPENING CYLINDER STOPPER	
54	C017401616	2	螺栓 M4X16	BOLT M4X16	
55	C021400202	2	六角螺母 M4	NUT 2 M4	
56	C062400816	4	螺钉 M4X8	SCREW PAN M4X8	
57	C028040242	4	弹簧垫圈 2-4	WASHER SPRING 2-4	
58	CS12004000	4	线性轴套	LINEAR BUSH	
59	CS02460001	8	轴用挡圈 C19	RETAINING RING, EXTERNAL C19	
60	CSA5692001	1	Y轴支座	Y BEARING	
61	CS12004000	1	线性轴套	LINEAR BUSH	
62	CS02460001	2	轴用挡圈 C19	RETAINING RING, EXTERNAL C19	
63	CSA5691001	1	Y导向轴	Y GUIDE SHAFT	
64	C012500536	2	螺钉 M5X5	SET SCREW SOCKET (FT) M5X5	



F1. 压脚装置 / Presser foot mechanism

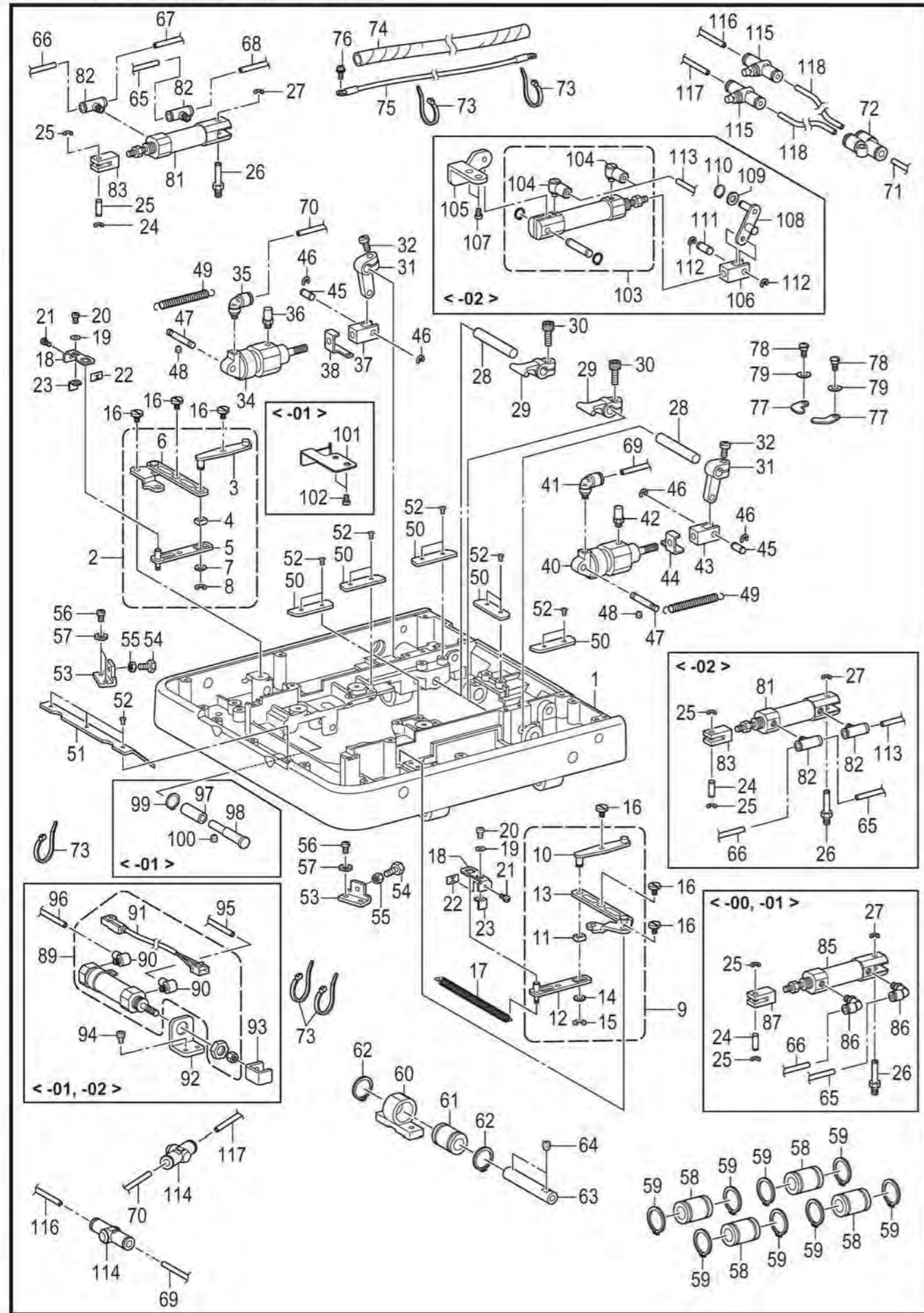

F1. 压脚装置 / Presser foot mechanism

参照号	零部件序号	数量	零部件名称	NAME OF PARTS	RM
65	CSA5681001	1	空气管 4X2.5-24	AIR TUBE 4X2.5-24	
66	CSA5682001	1	空气管 4X2.5-23	AIR TUBE 4X2.5-23	
67	CSA5683001	1	空气管 4X2.5-15	AIR TUBE 4X2.5-15	
68	CSA5684001	1	空气管 4X2.5-16	AIR TUBE 4X2.5-16	
69	CSA7973001	1	空气管 4X2.5-21	AIR TUBE 4X2.5-21	
70	CSA7974001	1	空气管 4X2.5-22	AIR TUBE 4X2.5-22	
71	CSA7975001	1	空气管 4X2.5-18	AIR TUBE 4X2.5-18	
72	CS12104000	1	结合管接头 Y4	UNION Y4	
73	CS04557000	5	电线夹 PLT1M	BAND, PLT1M	
74	CSA5688101	1	螺旋卷线 L	SPIRAL L	
75	CSA5435001	1	接地线 550	GROUND WIRE 550	
76	C052400606	1	螺钉(垫圈3点) M4X6	SCREW, PAN (S/P WASHER) M4X6	
77	CSA6727001	2	板夹	PLATE PRESSER	
78	CS35324201	2	段螺钉 M4	SHOULDER SCREW M4	
79	CS36345000	2	垫圈	WASHER, BENDING	
81	CSA7043001	1	<用于-00和-01> 气缸组件 T 16X15	<For -00 & -01> CYLINDER ASSY T 16X15	
82	CSA1828001	2	管接头 KQ2T04-M5	JOINT, KQ2T04-M5	
83	CS34970001	1	气缸杆	CYLINDER ROD OPENING	
85	CSA7050001	1	气缸组件 L 16X15	CYLINDER ASSY L 16X15	
86	CS11426000	2	弯管接头 4M5	ELBOW UNION 4M5	
87	CS34970001	1	气缸杆	CYLINDER ROD OPENING	
89	CSA5679001	1	<用于-01和-02> 气缸组件 B 16X30	<For -01 & -02> CYLINDER ASSY B 16X30	
90	CS12150000	2	管接头 M-5HL-4	TUBE ELBOW, M-5HL-4	
91	CSA6527001	1	感应器连线组件	LOWER OFF SENSOR ASSY	
92	CS34914101	1	气缸支架	T-TRIM. CYLINDER SUPPORT PLATE	
93	CS34913001	1	气缸手柄	THREAD TRIMMER CYLINDER CLAW	
94	C018400836	2	螺栓 M4X8	BOLT SOCKET M4X8	
95	CSA5680001	1	空气管 4X2.5-19	AIR TUBE 4X2.5-19	
96	CSA5561001	1	空气管 4X2.5-20	AIR TUBE 4X2.5-20	
97	CSA7053001	1	<用于-01> 轴套	<For -01> G-THREAD TAKE-UP GUIDE COLLER	
98	CSA7054001	1	短轴	G-THREAD TAKE-UP GUIDE SHAFT	
99	C048050142	1	轴用挡圈 C5	RETAINING RING EXTERNAL C5	
100	C014400532	1	螺钉 M4X5	SET SCREW SOCKET (CP) M4X5	
101	CSA7555001	1	板弹簧	FEED BAR PLATE SPRING	
102	C062400816	2	螺钉 M4X8	SCREW PAN M4X8	
81	CSA7043001	2	<用于-02> 气缸组件 T 16X15	<For -02> CYLINDER ASSY T 16X15	
82	CSA1828001	4	管接头 KQ2T04-M5	JOINT, KQ2T04-M5	
83	CS34970001	2	气缸杆	CYLINDER ROD OPENING	
103	CSA6719001	1	气缸组件 10X15	CYLINDER ASSY 10X15	
104	CS12150000	2	管接头 M-5HL-4	TUBE ELBOW, M-5HL-4	
105	CSA6720001	1	辅助压脚 S 支架	AUX CLAMP S HOLDER	
106	CS35351001	1	气缸杆	CYLINDER ROD	
107	C062400816	2	螺钉 M4X8	SCREW PAN M4X8	
108	CSA6721001	1	气缸杆销	AUX CLAMP CONNECTING ROD ASSY	
109	C025060236	1	平垫圈 M6	WASHER PLAIN M 6	
110	C048060142	1	轴用挡圈 C6	RETAINING RING EXTERNAL C6	
111	CSA6726001	1	气缸连杆销	CYLINDER ROD PIN	
112	C048030342	2	挡圈 E3	RETAINING RING E3	
113	CSA7131001	2	空气管 4X2.5-150	AIR TUBE 4X2.5-150	
114	CSA7795001	2	快速排气管	QUICK EXHAUST	
115	CSA7793001	2	速控 4	SPEED CONTROLLER	
116	CSA7976001	1	空气管 4X2.5-25	AIR TUBE 4X2.5-25	
117	CSA7977001	1	空气管 4X2.5-26	AIR TUBE 4X2.5-26	
118	CSA7978001	2	空气管 4X2.5-27	AIR TUBE 4X2.5-27	



F2. 压脚装置 / Presser foot mechanism

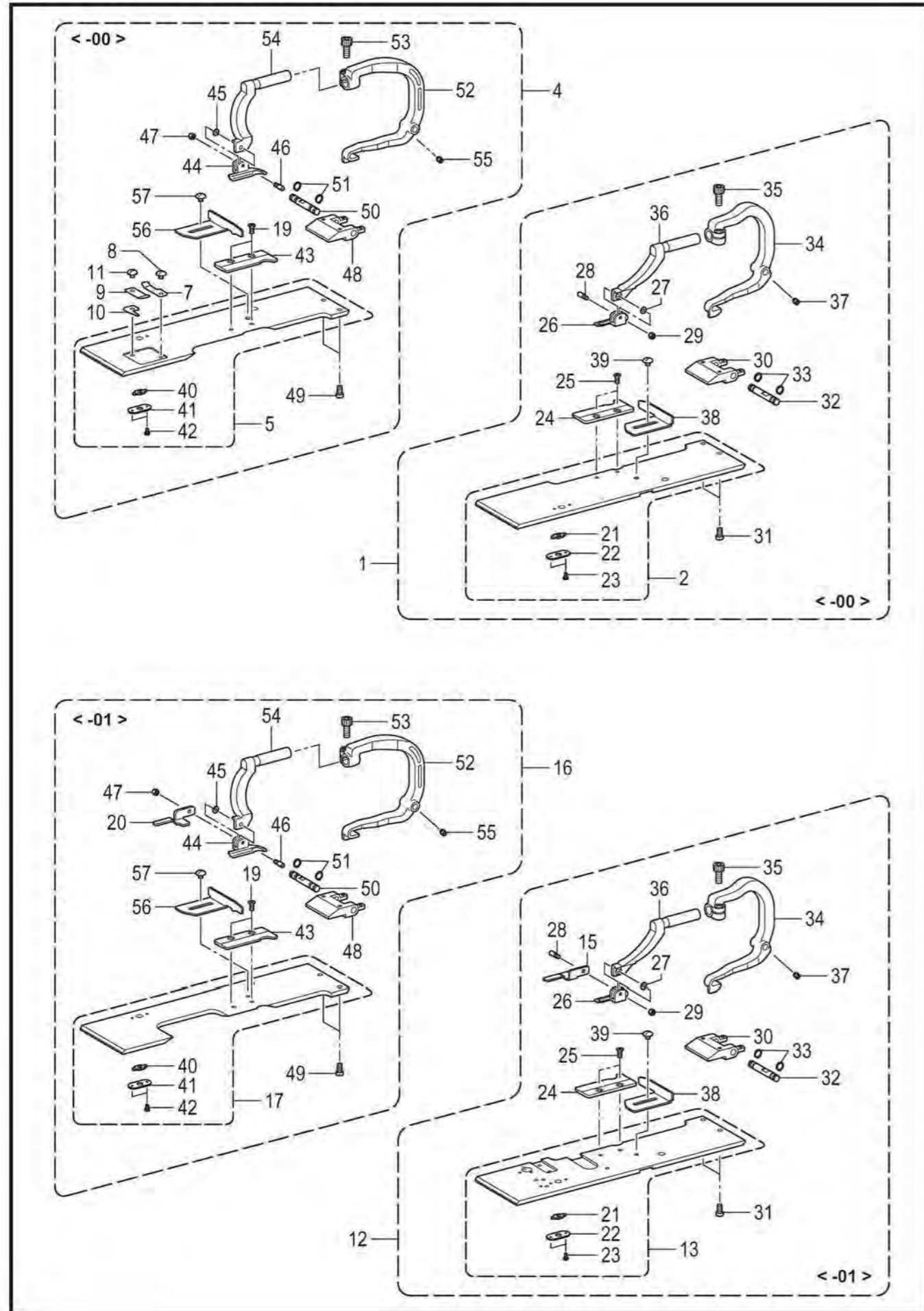

F2. 压脚装置 / Presser foot mechanism

参照号	零部件序号	数量	零部件名称	NAME OF PARTS	RM
			<用于-00>	<For -00>	
1	CSA7079001	1	压脚板总组件 R30	WORK CLAMP PLATE R30 UNIT	
2	CSA7080001	1	布压板组件 R	WORK CLAMP PLATE R ASSY	
4	CSA7082101	1	压脚板总组件 L30	WORK CLAMP PLATE L30 UNIT	
5	CSA7083001	1	布压板组件 L	WORK CLAMP PLATE L ASSY	
7	CSA7149001	1	板弹簧	PLATE SPRING	
8	CS35326101	1	螺钉 M3.5	SCREW M3.5	
9	CSA7150101	1	切线 A	THREAD TRIMMER A	
10	CSA7151101	1	切线 B	THREAD TRIMMER B	
11	CS35326101	1	螺钉 M3.5	SCREW M3.5	
			<用于-01>	<For -01>	
12	CSA7055001	1	压脚板总组件 RS30	WORK CLAMP PLATE RS30 UNIT	
13	CSA7056001	1	布压板组件 RS	WORK CLAMP PLATE RS ASSY	
15	CS35330001	1	压料板 R	WORK CLAMP PLATE, R	
16	CSA7060001	1	压脚板总组件 LS30	WORK CLAMP PLATE LS30 UNIT	
17	CSA7061001	1	布压板组件 LS	WORK CLAMP PLATE LS ASSY	
20	CS35329001	1	压料板 L	WORK CLAMP PLATE, L	
19	CS06696004	2	螺钉 M3X6	SCREW, FLAT M3X6	
21	CS35315001	1	角块	OPENING SLIDE BLOCK	
22	CS35316001	1	角块支撑板	SLIDE BLOCK SUPPORT PLATE	
23	C060020416	2	螺钉 M2X4	SCREW BIND M2X4	
24	CSA5673001	1	针板 R-42	NEEDLE PLATE R-42	
25	CS06696004	2	螺钉 M3X6	SCREW, FLAT M3X6	
26	CS39932101	1	压布 R-30	CLOTH WORK CLAMP, R-30	
27	CS35236000	1	垫圈 3.2	WASHER, BENDING 3.2	
28	CS35235001	1	支架销	SUPPORT PIN, CLAMP	
29	C021300306	1	螺母 M3	NUT 3 M3	
30	CSA5560001	1	夹轴承受板	CLAMP SHAFT HOLDER	
31	C062400816	2	螺钉 M4X8	SCREW PAN M4X8	
32	CSA5674001	1	支点轴	CLAMP FULCRUM SHAFT	
33	C048060142	2	轴用挡圈 C6	RETAINING RING EXTERNAL C6	
34	CSA5585001	1	夹杆 R	CLAMP LEVER R	
35	C018501236	1	螺栓 M5X12	BOLT SOCKET M5X12	
36	CSA5576001	1	夹臂 R	CLAMP ARM R	
37	C014400532	2	螺钉 M4X5	SET SCREW SOCKET (CP) M4X5	
38	CSA7550001	1	布挡板 R	CROTH GUIDE R	
39	CS35326101	1	螺钉 M3.5	SCREW M3.5	
40	CS35315001	1	角块	OPENING SLIDE BLOCK	
41	CS35316001	1	角块支撑板	SLIDE BLOCK SUPPORT PLATE	
42	C060020416	2	螺钉 M2X4	SCREW BIND M2X4	
43	CSA5672001	1	针板 L-42	NEEDLE PLATE L-42	
44	CS39931101	1	压布 L-30	CLOTH WORK CLAMP, L-30	
45	CS35236000	1	垫圈 3.2	WASHER, BENDING 3.2	
46	CS35235001	1	支架销	SUPPORT PIN, CLAMP	
47	C021300306	1	螺母 M3	NUT 3 M3	
48	CSA5560001	1	夹轴承受板	CLAMP SHAFT HOLDER	
49	C062400816	2	螺钉 M4X8	SCREW PAN M4X8	
50	CSA5674001	1	支点轴	CLAMP FULCRUM SHAFT	
51	C048060142	2	轴用挡圈 C6	RETAINING RING EXTERNAL C6	
52	CSA5671001	1	夹杆 L	CLAMP LEVER L	
53	C018501236	1	螺栓 M5X12	BOLT SOCKET M5X12	
54	CSA5577001	1	夹臂 L	CLAMP ARM L	
55	C014400532	2	螺钉 M4X5	SET SCREW SOCKET (CP) M4X5	
56	CSA7551001	1	布挡板 L	CROTH GUIDE L	
57	CS35326101	1	螺钉 M3.5	SCREW M3.5	



F3. 压脚装置 / Presser foot mechanism

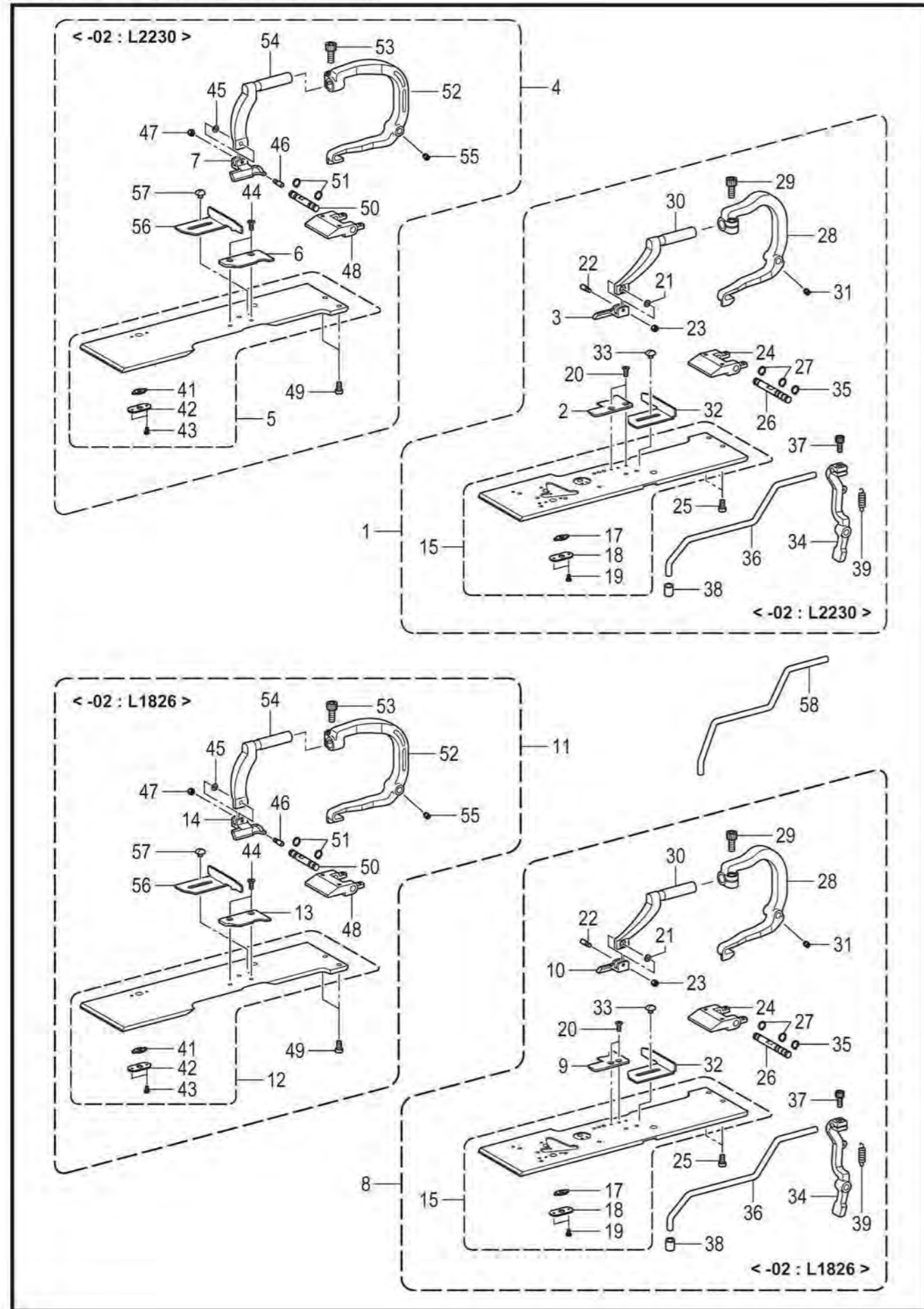

F3. 压脚装置 / Presser foot mechanism

参照号	零部件序号	数量	零部件名称	NAME OF PARTS	RM
1	CSA6728001	1	<用于-02: L2230> 压脚板组件 R2230	<For -02: L2230> WORK CLAMP PLATE R2230 UNIT	
2	CSA6731001	1	针板 L2230R	NEEDLE PLATE L 2230R	
3	CSA6732001	1	压布板 R-JL2230	WORK CLAMP R-JL2230	
4	CSA6738001	1	压脚板组件 L2230	WORK CLAMP PLATE L2230 UNIT	
5	CSA6739001	1	布压板组件 JL	WORK CLAMP PLATE JL ASSY	
6	CSA6741001	1	针板 L2230L	NEEDLE PLATE L 2230L	
7	CSA6742001	1	压布板 L-JL2230	WORK CLAMP L-JL2230	
8	CSA7187001	1	<用于-02: L1826> 压脚板组件 R1826	<For -02: L1826> WORK CLAMP PLATE R1826 ASSY	
9	CSA7105001	1	针板 L1826R	NEEDLE PLATE L1826R	
10	CSA7095001	1	布压板 R-JL1826	WORK CLAMP R-JL1826	
11	CSA7186001	1	压脚板组件 L1826	WORK CLAMP PLATE L1826 ASSY	
12	CSA6739001	1	布压板组件 JL	WORK CLAMP PLATE JL ASSY	
13	CSA7100001	1	针板 L1826L	NEEDLE PLATE L1826L	
14	CSA7090001	1	布压板 L-JL1826	WORK CLAMP L-JL1826	
15	CSA6729001	1	布压板组件 JR	WORK CLAMP PLATE JR UNIT	
17	CS35315001	1	角块	OPENING SLIDE BLOCK	
18	CS35316001	1	角块支撑板	SLIDE BLOCK SUPPORT PLATE	
19	C060020416	2	螺钉 M2X4	SCREW BIND M2X4	
20	CS06696004	2	螺钉 M3X6	SCREW, FLAT M3X6	
21	CS35236000	1	垫圈 3.2	WASHER, BENDING 3.2	
22	CS35235001	1	支架销	SUPPORT PIN, CLAMP	
23	C021300306	1	螺母 M3	NUT 3 M3	
24	CSA5560001	1	夹轴承受板	CLAMP SHAFT HOLDER	
25	C062400816	2	螺钉 M4X8	SCREW PAN M4X8	
26	CSA6733001	1	支点轴 J	CLAMP FULCRUM SHAFT J	
27	C048060142	2	轴用挡圈 C6	RETAINING RING EXTERNAL C6	
28	CSA5585001	1	夹杆 R	CLAMP LEVER R	
29	C018501236	1	螺栓 M5X12	BOLT SOCKET M5X12	
30	CSA6734001	1	夹臂 R-J	CLAMP ARM R-J	
31	C014400532	2	螺钉 M4X5	SET SCREW SOCKET (CP) M4X5	
32	CSA7550001	1	布挡板 R	CROTH GUIDE R	
33	CS35326101	1	螺钉 M3.5	SCREW M3.5	
34	CSA6735001	1	辅助压脚臂	AUX CLAMP ARM	
35	C048060142	1	轴用挡圈 C6	RETAINING RING EXTERNAL C6	
36	CSA6736001	1	辅助压脚杆	SUB AUX CLAMP WRIST	
37	C018401036	1	螺栓 M4X10	BOLT SOCKET M4X10	
38	CS05356000	1	扣夹 A	BUTTON CLAMP, A	
39	CSA6737001	1	回复弹簧	AUX CLAMP TSWIST SPRING	
41	CS35315001	1	角块	OPENING SLIDE BLOCK	
42	CS35316001	1	角块支撑板	SLIDE BLOCK SUPPORT PLATE	
43	C060020416	2	螺钉 M2X4	SCREW BIND M2X4	
44	CS06696004	2	螺钉 M3X6	SCREW, FLAT M3X6	
45	CS35236000	1	垫圈 3.2	WASHER, BENDING 3.2	
46	CS35235001	1	支架销	SUPPORT PIN, CLAMP	
47	C021300306	1	螺母 M3	NUT 3 M3	
48	CSA5560001	1	夹轴承受板	CLAMP SHAFT HOLDER	
49	C062400816	2	螺钉 M4X8	SCREW PAN M4X8	
50	CSA5674001	1	支点轴	CLAMP FULCRUM SHAFT	
51	C048060142	2	轴用挡圈 C6	RETAINING RING EXTERNAL C6	
52	CSA5671001	1	夹杆 L	CLAMP LEVER L	
53	C018501236	1	螺栓 M5X12	BOLT SOCKET M5X12	
54	CSA6743001	1	夹臂 L-J	CLAMP ARM L-J	
55	C014400532	2	螺钉 M4X5	SET SCREW SOCKET (CP) M4X5	
56	CSA7551001	1	布挡板 L	CROTH GUIDE L	
57	CS35326101	1	螺钉 M3.5	SCREW M3.5	
58	CSA7152001	1	<选购件> 辅助压脚杆 L	<Option parts> SUPPORT WORK CLAMP ARM L	



G. 送布装置 / Feed mechanism

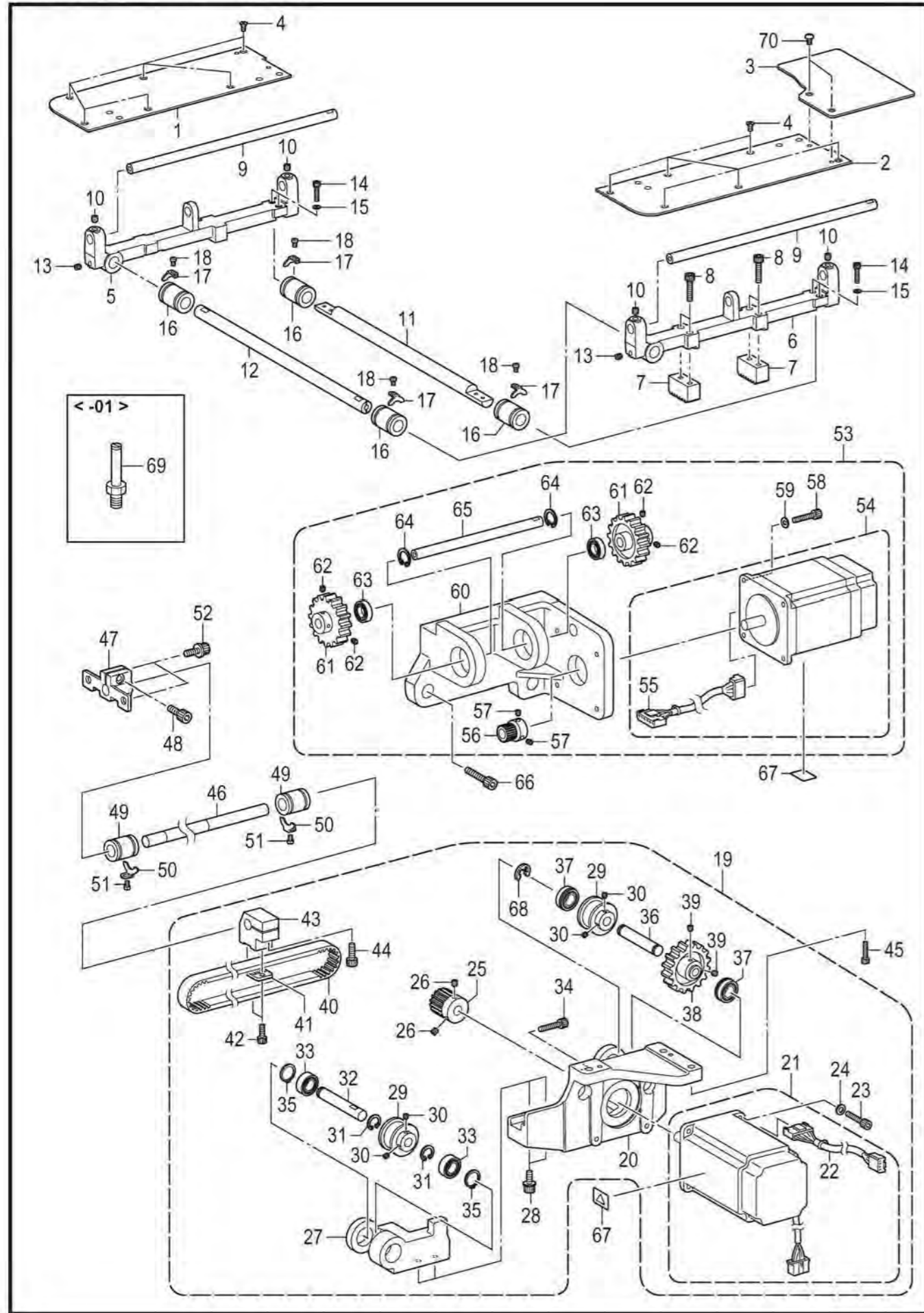

G. 送布装置 / Feed mechanism

参照号	零部件序号	数量	零部件名称	NAME OF PARTS	RM
1	CSA6744001	1	送料台盖 L	FEED BAR COVER L	
2	CSA6745001	1	送料台盖 R	FEED BAR COVER R	
3	CSA8121001	1	送料台盖组件 U	FEED BAR COVER U ASSY	
4	C004401003	12	螺钉 M4X10	SCREW, FLAT M4X10	
5	CSA6747001	1	X送布轴架 S	X FEED SHAFT HOLDER S	
6	CSA6748001	1	X送布轴架 N	X FEED SHAFT HOLDER N	
7	CSA6749001	2	X齿条	X RACK	
8	C018501636	4	螺栓 M5X16	BOLT SOCKET M5X16	
9	CSA6750001	2	Y送布导向轴	Y FEED GUIDE SHAFT	
10	C012060636	4	螺钉 M6X6	SET SCREW SOCKET (FT) M6X6	
11	CSA6751101	1	X送布导向轴 A	X FEED GUIDE SHAFT A	
12	CSA6752101	1	X送布导向轴 B	X FEED GUIDE SHAFT B	
13	C012060636	2	螺钉 M6X6	SET SCREW SOCKET (FT) M6X6	
14	C018401636	4	螺栓 M4X16	BOLT SOCKET M4X16	
15	C025040136	4	平垫圈 S4	WASHER PLAIN S 4	
16	CS35183000	4	直线形轴套 12	LINEAR BUSH, 12	
17	CSA5562001	4	定位板	BALL BEARING STOPPER	
18	C062300416	4	螺钉 M3X4	SCREW PAN M3X4	
19	CSA6753001	1	Y送料组件	Y FEED ASSY	
20	CSA6754001	1	Y送布基座	Y FEED BASE	
21	CSA6521001	1	脉冲马达组件 Y	PULSE MOTOR ASSY Y	
22	CSA6522001	1	马达接线 Y	MOTOR HARNESS Y	
23	C018401436	4	螺栓 M4X14	BOLT SOCKET M4X14	
24	C026040136	4	平垫圈 S4	WASHER PLAIN S 4	
25	CSA6755001	1	驱动齿轮 20	DRIVING GEAR 20	
26	C012060636	2	螺钉 M6X6	SET SCREW SOCKET (FT) M6X6	
27	CSA6756001	1	Y轮基座	Y PULLEY SUPPORT	
28	C3A6001001	2	螺栓(带垫圈) M5X20	BOLT SOCKET (S/P WASHER) M5X20	
29	CSA6757001	2	Y同步轮组件	Y TIMING PULLEY ASSY	
30	C012060636	4	螺钉 M6X6	SET SCREW SOCKET (FT) M6X6	
31	C048160242	2	轴用挡圈 C16	RETAINING RING INTERNAL C16	
32	CSA6760001	1	Y手轮轴 R	Y PULLEY SHAFT R	
33	C530138001	2	微轴承 8	BALL BEARING MICRO 8	
34	C018502536	1	螺栓 M5X25	BOLT SOCKET M5X25	
35	C048080142	2	轴用挡圈 C8	RETAINING RING EXTERNAL C8	
36	CSA6761001	1	Y手轮轴 F	Y PULLEY SHAFT F	
37	C070688850	2	R球轴承 688ZZ	BALL BEARING RADIAL 688ZZ	
38	CSA6762001	1	空转齿轮 40	IDLER GEAR 40	
39	C012060636	2	螺钉 M6X6	SET SCREW SOCKET (FT) M6X6	
40	CSA6763001	1	T皮带 320-5GT	T BELT 320-5GT	
41	CSA6764001	1	皮带支板	BELT HOLDER	
42	C018400836	2	螺栓 M4X8	BOLT SOCKET M4X8	
43	CSA6765001	1	Y驱动轴支架	Y DRIVING SHAFT HOLDER	
44	C018501636	1	螺栓 M5X16	BOLT SOCKET M5X16	
45	C018061636	3	螺栓 M6X16	BOLT SOCKET M6X16	
46	CSA6766001	1	Y轴	Y SHAFT	
47	CSA6767001	1	Y轴支架	Y SHAFT HOLDER	
48	C018501436	1	螺栓 M5X14	BOLT SOCKET M5X14	
49	CS12004000	2	线性轴套	LINEAR BUSH	
50	CSA5562001	2	定位板	BALL BEARING STOPPER	
51	C062300416	2	螺钉 M3X4	SCREW PAN M3X4	
52	CS55476001	2	螺栓(带垫圈) M6X12	BOLT SOCKET (S/P WASHER)M6X12	
53	CSA6768001	1	X送料组件	X FEED ASSY	
54	CSA6517001	1	脉冲马达组件 X	PULSE MOTOR ASSY X	
55	CSA6518001	1	马达接线 X	MOTOR HARNESS X	
56	CSA4197001	1	送料齿轮	FEED GEAR	
57	C012060636	2	螺钉 M6X6	SET SCREW SOCKET (FT) M6X6	
58	C018401436	4	螺栓 M4X14	BOLT SOCKET M4X14	
59	C026040136	4	平垫圈 S4	WASHER PLAIN S 4	
60	CSA6769001	1	X马达支座	X MOTOR SUPPORT	
61	CSA6770001	2	空转齿轮	IDLER GEAR	
62	C012060636	4	螺钉 M6X6	SET SCREW SOCKET (FT) M6X6	
63	CSA6771001	2	轴承 6001ZZ	BALL BEARING 6001ZZ	



G. 送布装置 / Feed mechanism

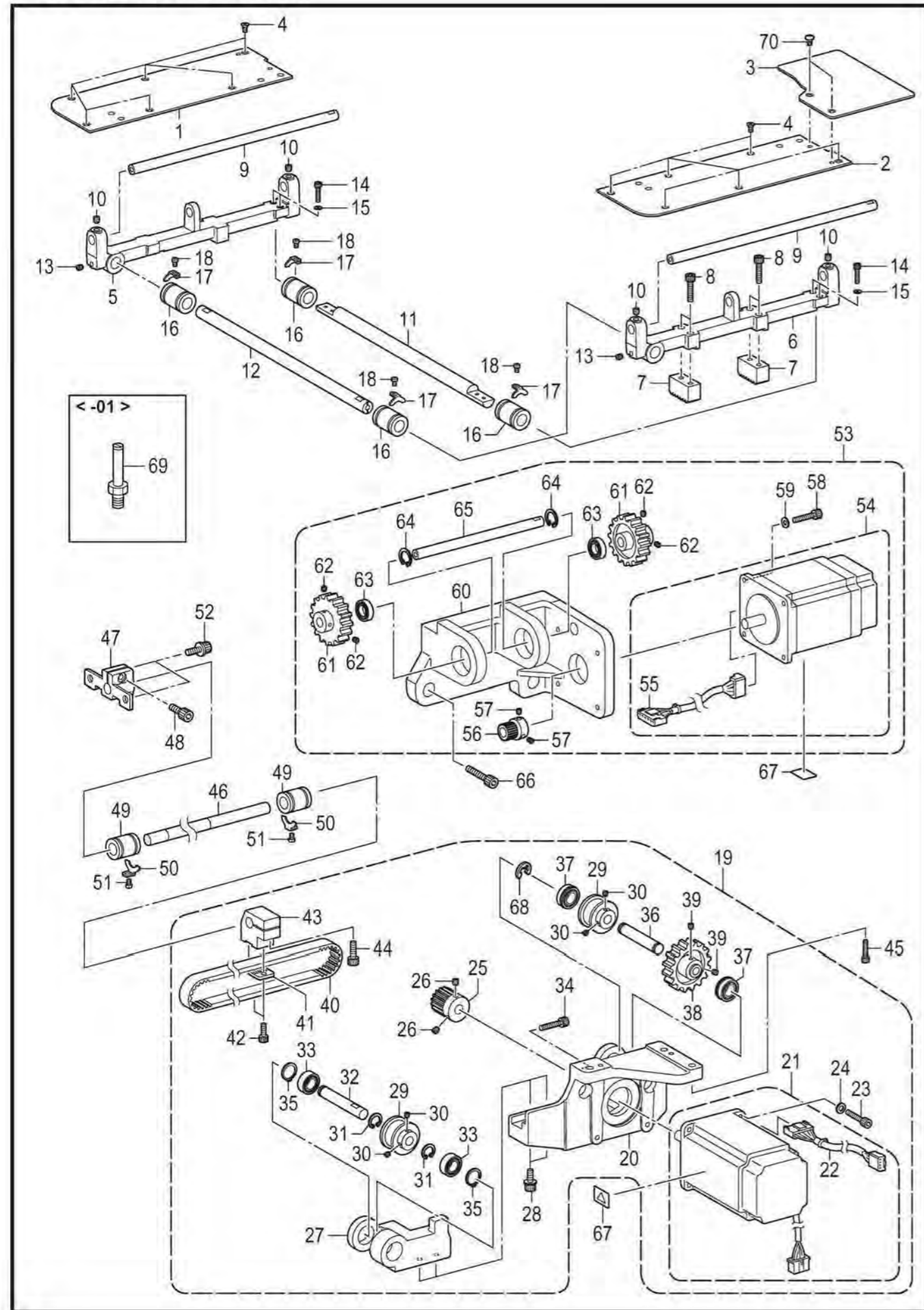

G. 送布装置 / Feed mechanism

参照号	零部件序号	数量	零部件名称	NAME OF PARTS	RM
64	C048280242	2	孔用挡圈 C28	RETAINING RING INTERNAL C28	
65	CSA6772001	1	X空转齿轮轴	X IDLER GEAR SHAFT	
66	C018061636	3	螺栓 M6X16	BOLT SOCKET M6X16	
67	CJ03663001	2	高温标签 13X20	LABEL, HIGH TEMP. 13X20	
68	C048060342	1	挡圈 E6	RETAINING RING E6	
70	C008401204	2	螺钉 M4X12	SCREW TRUSS M4X12	
69	CSA5584001	1	<用于-01> 气缸螺栓	<For -01> CYLINDER SCREW	



H. 切刀装置 / Cutter mechanism

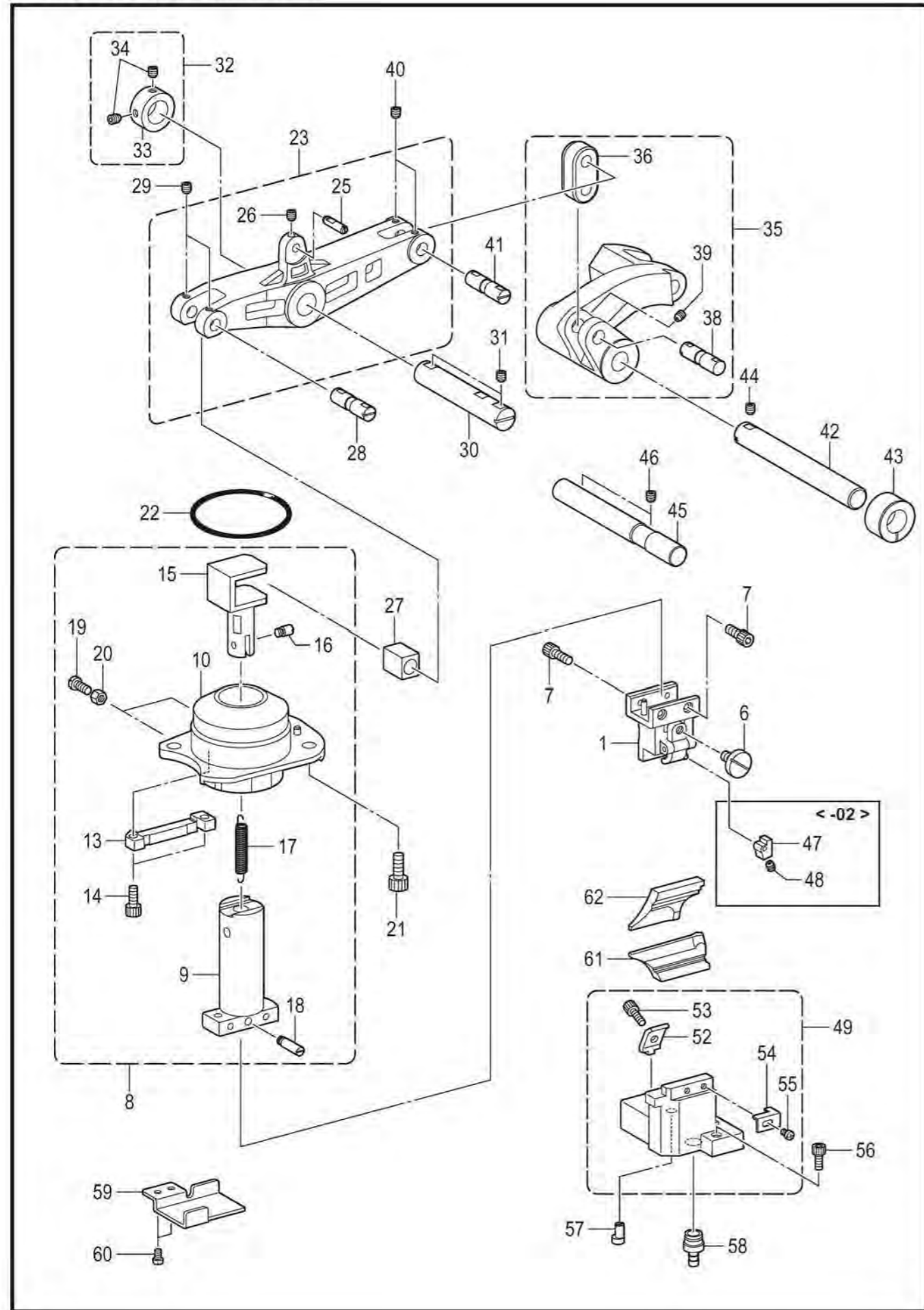

H. 切刀装置 / Cutter mechanism

参照号	零部件序号	数量	零部件名称	NAME OF PARTS	RM
1	CSA6773101	1	气锤基座组件	HAMMER BRACKET ASSY	
6	CS35091101	1	螺栓 M5	KNOB SCREW M5	
7	C018401036	4	螺栓 M4X10	BOLT SOCKET M4X10	
8	CSA6776301	1	切刀动作轴组件	CUTTER DRIVING SHAFT ASSY	
9	CSA6777001	1	切刀动作轴	CUTTER DRIVING SHAFT	
10	CSA6778301	1	切刀轴套组件	BUSH C-SHAFT ASSY	
13	CSA6781001	1	回转制动	GUIDE BLOCK	
14	C018401236	2	螺栓 M4X12	BOLT SOCKET M4X12	
15	CSA6782001	1	切刀轴压杆	DRIVING SHAFT PRESSER	
16	CSA6783001	1	弹簧挂钩 U	SPRING HOOK PIN U	
17	CSA6784001	1	弹簧	SPRING EXTENSION	
18	CSA6785001	1	弹簧挂钩 D	SPRING HOOK PIN D	
19	CSA6786001	2	螺钉 4	BOLT 4	
20	C021400206	2	六角螺母 M4	NUT 2 M4	
21	C018061236	3	螺栓 M6X12	BOLT SOCKET M6X12	
22	C081050870	1	O形圈 S50	O RING S50	
23	CSA6787001	1	切刀臂组件	CUTTER ARM ASSY	
25	CSA6789001	1	切刀销	C-SENSOR PIN	
26	C012500536	1	螺钉 M5X5	SET SCREW SOCKET (FT) M5X5	
27	CSA6790001	1	切刀臂滑块	C-ARM SLIDE BLOCK	
28	CSA5563001	1	切刀臂销	C-ARM PIN	
29	C014060836	2	固定螺钉 M6X8	SET SCREW SOCKET (CP) M6X8	
30	CSA6791001	1	切刀臂轴	C-ARM SHAFT	
31	C012061036	2	螺钉 M6X10	SET SCREW SOCKET (FT) M6X10	
32	CSA6792001	1	紧圈组件	SET SCREW COLLAR ASSY	
33	CSA6793001	1	紧圈	SET SCREW COLLAR	
34	C014060836	2	固定螺钉 M6X8	SET SCREW SOCKET (CP) M6X8	
35	CSA6794001	1	切刀杆组件	CUTTER LEVER ASSY	
36	CSA6795001	1	切刀连接杆	CUTTER LINK	
38	CSA5563001	1	切刀臂销	C-ARM PIN	
39	C014500836	2	螺钉 M5X8	SET SCREW SOCKET (CP) M5X8	
40	C014060836	2	固定螺钉 M6X8	SET SCREW SOCKET (CP) M6X8	
41	CSA5563001	1	切刀臂销	C-ARM PIN	
42	CSA6797001	1	切刀杆轴	CUTTER REVER SHAFT	
43	CSA6798001	1	切刀杆轴套	BUSH C-LEVER SHAFT	
44	C012061036	1	螺钉 M6X10	SET SCREW SOCKET (FT) M6X10	
45	CSA6799001	1	气缸支撑轴	CYLINDER SUPPORT SHAFT	
46	C014060836	2	固定螺钉 M6X8	SET SCREW SOCKET (CP) M6X8	
			<用于-02>	<For -02>	
47	CSA6800001	1	气锤垫块	HAMMER SPACER	
48	C014400536	1	螺钉 M4X5	SET SCREW SOCKET(CP) M4X5	
49	CSA6801301	1	切刀基座总组件	KNIFE BRACKET UNIT	
52	CS35097101	1	切刀基座架	KNIFE BLOCK HOLDER	
53	C018501636	1	螺栓 M5X16	BOLT SOCKET M5X16	
54	CS35098000	1	基座定位板	BLOCK STOPPER PLATE	
55	C062300416	1	螺钉 M3X4	SCREW PAN M3X4	
56	C018501636	3	螺栓 M5X16	BOLT SOCKET M5X16	
57	CSA6804001	1	偏心销	ECCENTRIC PIN	
58	CSA6805001	1	切刀屑接头	KNIFE GARBAGE JOINT	
59	CSA6985001	1	管夹板	TUBE GUIDE	
60	C062400816	1	螺钉 M4X8	SCREW PAN M4X8	
61	CSA6806001	1	切刀 2.8X4.3-42	KNIFE 2.8X4.3-42	
62	C* P. 102	1	气锤	HAMMER	



J. 下轴装置 / Lower shaft mechanism

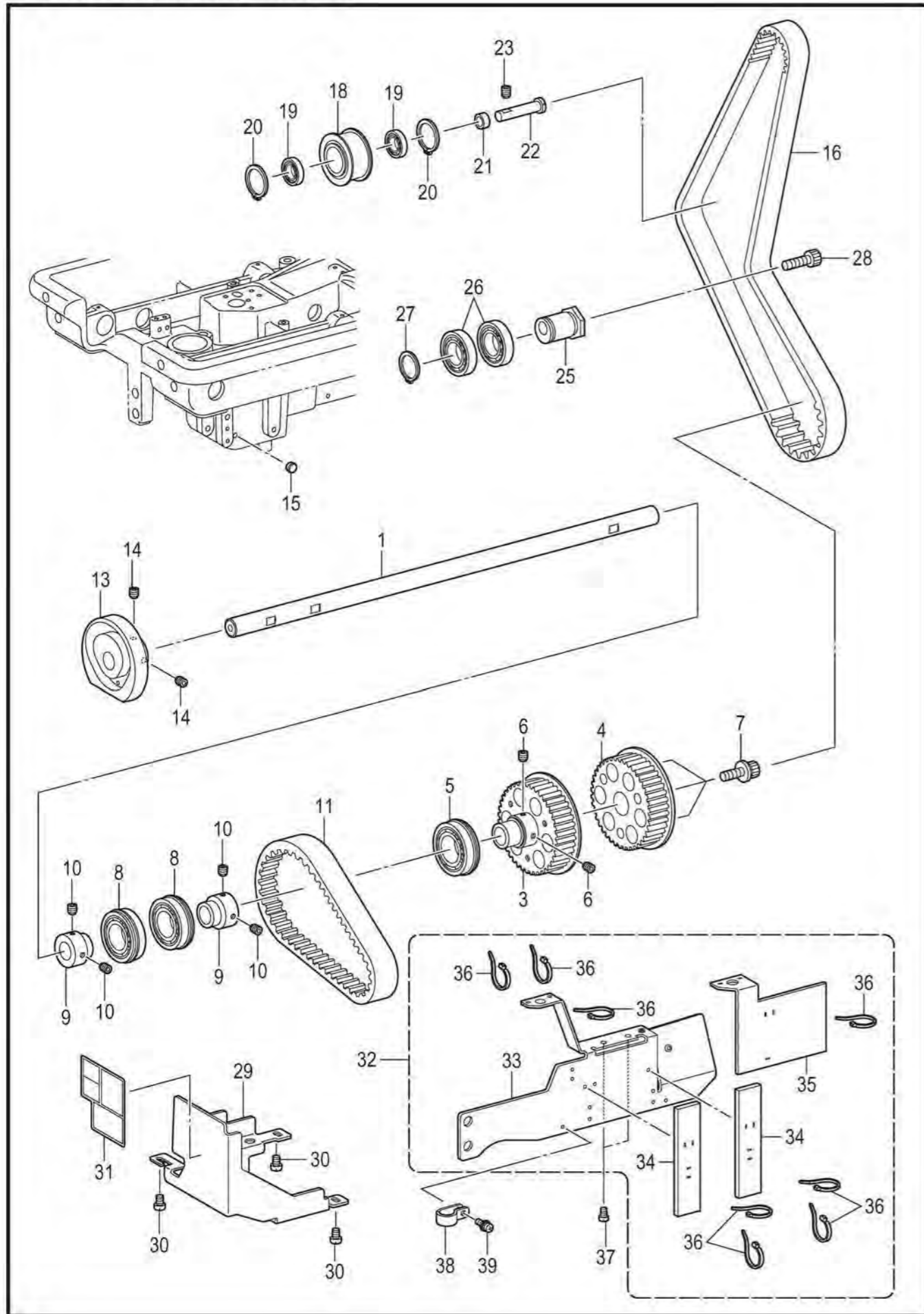

J. 下轴装置 / Lower shaft mechanism

参照号	零部件序号	数量	零部件名称	NAME OF PARTS	RM
1	CSA6807001	1	下轴	LOWER SHAFT	
3	CSA6809001	1	下轴T手轮 A	LOWER SHAFT TENSION PULLEY A	
4	CSA6810001	1	下轴T手轮 B	LOWER SHAFT TENSION PULLEY B	
5	CSA5571001	1	轴承 6004ZZNR	BALL BEARING 6004ZZNR	
6	CS23651001	2	固定螺钉 M6X6	SET SCREW SOCKET (FT) M6X6	
7	CS47270001	3	螺栓(带垫圈) M6X30	BOLT SOCKET (S/P WASHER)M6X30	
8	CSA5573001	2	轴承 6204ZZNR	BALL BEARING 6204ZZNR	
9	CSA5564001	2	轴承管套	BEARING COLLAR	
10	CS23651001	4	固定螺钉 M6X6	SET SCREW SOCKET (FT) M6X6	
11	CSA6812001	1	T皮带 375-5GT	T BELT 375-5GT	
13	CSA6814001	1	下轴凸轮	LOWER SHAFT CAM	
14	CS23651001	2	固定螺钉 M6X6	SET SCREW SOCKET (FT) M6X6	
15	C104833001	1	橡皮塞 4.3	RUBBER CAP, 4.3	
16	CSA6815001	1	T皮带 1115-5GT	T BELT 1115-5GT	
18	CSA6817001	1	空转轮组件	IDLER PULLEY ASSY	
19	CSA5570001	2	轴承 608ZZ	BALL BEARING 608ZZ	
20	C048220242	2	孔用挡圈 C22	RETAINING RING INTERNAL C22	
21	CS50168001	1	惰轮管套	COLLAR	
22	CSA6819001	1	空转轮轴	IDLER PULLEY SHAFT	
23	C012061036	1	螺钉 M6X10	SET SCREW SOCKET (FT) M6X10	
25	CSA6821001	1	张力轮套	TENSION PULLEY COLLAR	
26	CSA5572001	2	轴承 6004ZZ	BALL BEARING 6004ZZ	
27	C048200142	1	轴用挡圈 C20	RETAINING RING EXTERNAL C20	
28	C018084036	1	螺栓 M8X40	BOLT SOCKET M8X40	
29	CSA6822001	1	凸轮盖	CAM COVER	
30	C062500816	3	螺钉 M5X8	SCREW PAN M5X8	
31	CSA6823001	1	底线穿线表	LOWER THREADER LABEL	
32	CSA6824001	1	下轴盖组件	LOWER SHAFT COVER ASSY	
33	CSA6825001	1	下轴盖	LOWER SHAFT COVER	
34	CSA6826001	2	下轴盖油毡 A	LOWER SHAFT COVER FELT A	
35	CSA6827001	1	下轴盖油毡 B	LOWER SHAFT COVER FELT B	
36	C228475000	8	电线夹 1.9X80	FASTENING BAND 1.9X80	
37	C062400816	2	螺钉 M4X8	SCREW PAN M4X8	
38	CS10243000	1	尼龙夹 NK-3N	CORD HOLDER, NK-3N	
39	C0A4400806	1	螺栓(带垫圈) M4X8DA	SCREW PAN (S/P WASHER) M4X8	



K. 弯针装置 / Looper mechanism

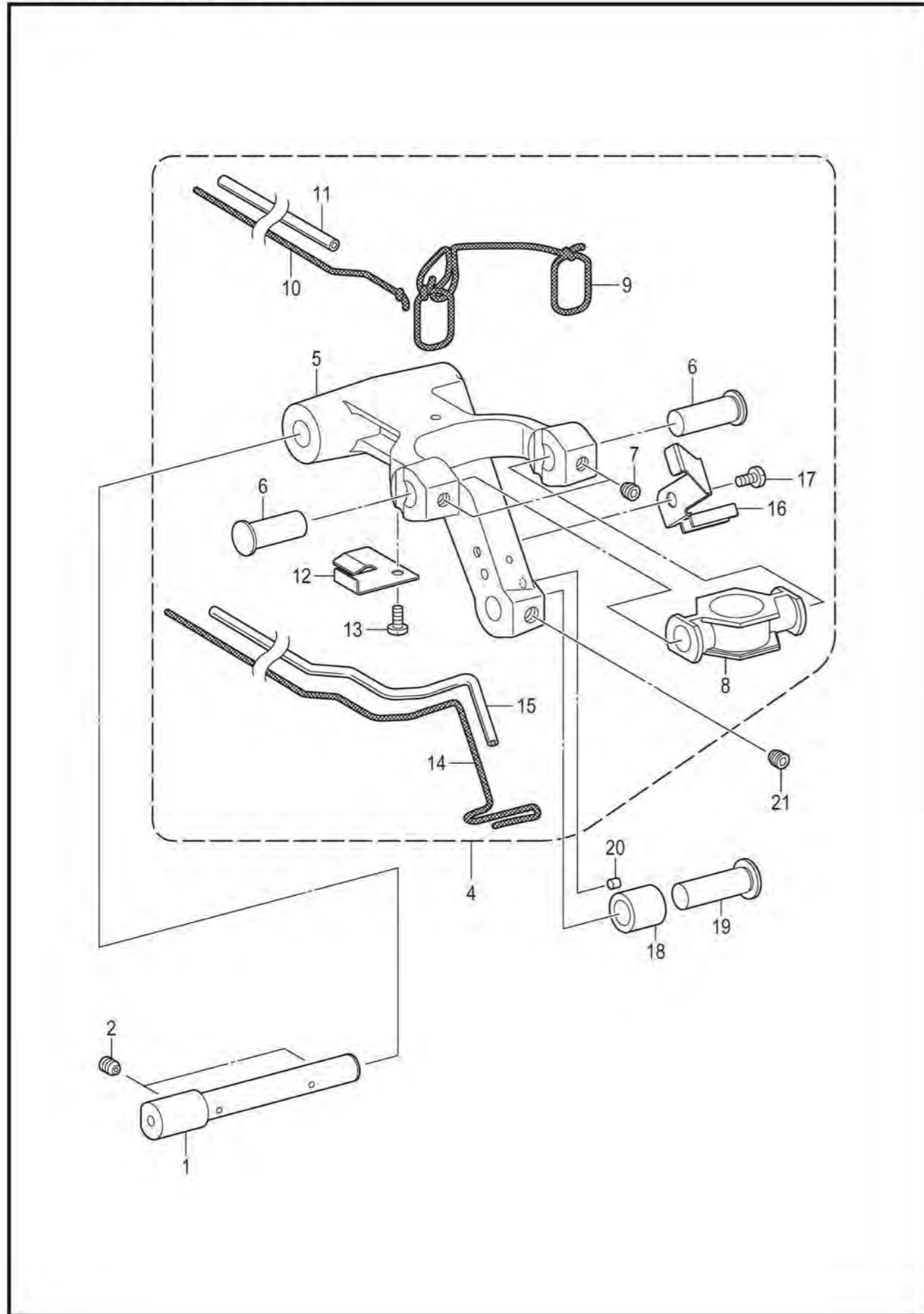

K. 弯针装置 / Looper mechanism

参照号	零部件序号	数量	零部件名称	NAME OF PARTS	RM
1	CSA6828001	1	弯针杆轴	LOOPER LEVER SHAFT	
2	C014500836	2	螺钉 M5X8	SET SCREW SOCKET (CP) M5X8	
4	CSA6829001	1	弯针杆组件	LOOPER LEVER ASSY	
5	CSA6830001	1	弯针杆	LOOPER LEVER	
6	CSA6831001	2	短轴 6.35	SHAFT 6.35	
7	C012500536	2	螺钉 M5X5	SET SCREW SOCKET (FT) M5X5	
8	CSA6834001	1	弯针作动台	LOOPER DRIVING PLATE	
9	CSA6835001	1	油线 2X2	WICK 2X2	
10	CSA6836001	1	油线 2X2	WICK 2X2	
11	CSA5565001	1	油管	OIL TUBE	
12	CSA6837001	1	油管夹 A	LOOPER TUBE CLAMP A	
13	C060300816	1	螺钉 M3X8	SCREW BIND M3X8	
14	CSA6838001	1	油线 3X3	WICK 3X3	
15	CSA6839001	1	油管	OIL TUBE	
16	CSA6840001	1	油管夹 B	LOOPER TUBE CLAMP B	
17	C060300816	1	螺钉 M3X8	SCREW BIND M3X8	
18	CSA6832101	1	下轴凸轮管套	LOWER SHAFT CAM COLLAR	
19	CSA6833001	1	弯针凸轮滚轮轴	LOOPER CAM ROLLER SHAFT	
20	CS12718000	1	毡	CHEMICAL FELT	
21	C014060632	1	固定螺钉 M6X6	SET SCREW SOCKET (CP) M6X6	



L. 双链式弯针装置 / Double chain stitch looper mechanism

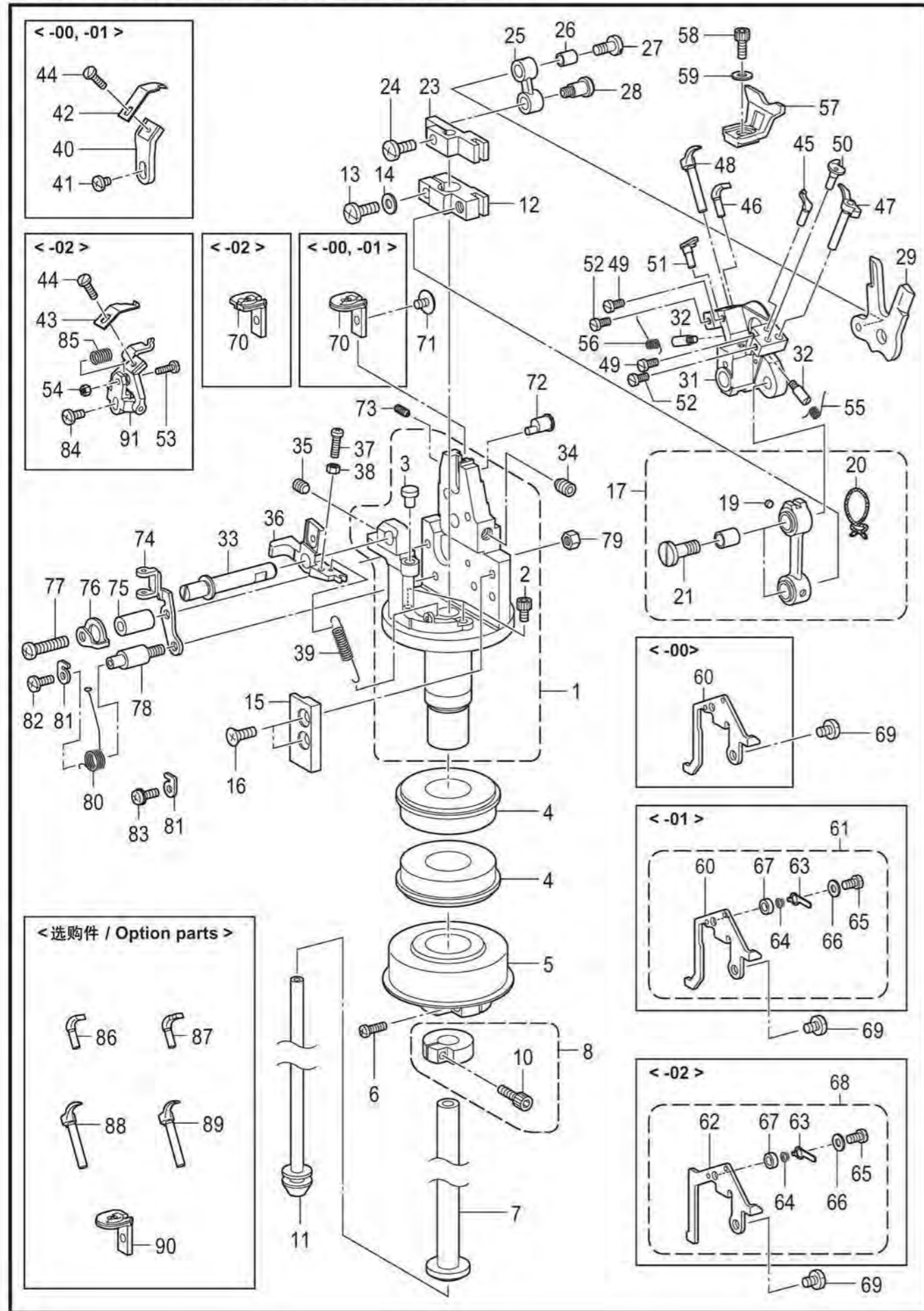

L. 双链式弯针装置 / Double chain stitch looper mechanism

参照号	零部件序号	数量	零部件名称	NAME OF PARTS	RM
1	CSA6841101	1	弯针座组件	LOOPER BASE ASSY	
2	C018400636	2	螺栓 M4X6	BOLT SOCKET M4X6	
3	CSA6844001	1	定位销 4	INPUT PIN 4	
4	CSA5571001	2	轴承 6004ZZNR	BALL BEARING 6004ZZNR	
5	CSA6845001	1	弯针轮组件	LOOPER PULLEY ASSY	
6	C062351615	1	螺钉 M3.5X16	SCREW PAN M3.5X16	
7	CSA6848001	1	弯针驱动轴	LOOPER DRIVING SHAFT	
8	CSA6849001	1	弯针驱动轴抱箍组件	LOOPER DRIVING SHAFT ASSY	
10	C018301436	1	螺栓 M3X14	BOLT SOCKET M3X14	
11	CSA6851001	1	叉板连杆轴	SPREADER LINK SHAFT	
12	CSA6852001	1	弯针连杆支点	LOOPER LINK CLAMP	
13	C060401416	1	螺钉 M4X14	SCREW BIND M4X14	
14	C026040136	1	平垫圈 S4	WASHER PLAIN S 4	
15	CSA6853001	1	LS滑块导向	LS SLIDE GUIDE	
16	C004401003	2	螺钉 M4X10	SCREW, FLAT M4X10	
17	CSA7204101	1	弯针连杆总组件	LOOPER LINK UNIT	
19	CS52832000	1	油毡	FELT	
20	CSA6857001	1	油线 2X2	WICK 2X2	
21	CSA6858001	2	固定螺栓	LOOPER LINK FASTENING SCREW	
23	CSA6859001	1	叉板连杆底座	SPREADER LINK BASE	
24	C060401016	1	螺钉 M4X10	SCREW BIND M4X10	
25	CSA6860001	1	叉板凸轮连杆	SPREADER CAM LINK	
26	CS35018001	1	凸轮连杆管套	CAM LINK COLLOR	
27	CS35014001	1	段螺钉 M4	SHOULDER SCREW, M4	
28	CS35019001	1	段螺钉 M4	SHOULDER SCREW, M4	
29	CSA6861001	1	叉板驱动凸轮	SPREADER DRIVING CAM	
31	CSA6863001	1	LS支撑底座	LS HOLDER BASE	
32	CSA6864001	2	弹簧导向螺钉	SPRING GUIDE SCREW	
33	CSA6865001	1	支撑短轴	HOLDER PRESSER SHAFT	
34	C014060836	1	固定螺钉 M6X8	SET SCREW SOCKET (CP) M6X8	
35	C012500536	1	螺钉 M5X5	SET SCREW SOCKET (FT) M5X5	
36	CSA6866001	1	切线杆底座	THREAD TRIMMER LEVER BRACKET	
37	C062301016	1	螺钉 M3X10	SCREW PAN M3X10	
38	C021300306	1	螺母 M3	NUT 3 M3	
39	CSA6867001	1	U切线弹簧	U THREAD TRIMMER SPRING	
40	CSA7064001	1	<用于-00和-01> 上动刀台	<For -00 & -01> UPPER MOVABLE KNIFE	
41	C060300416	1	螺钉 M3X4	SCREW BIND M3X4	
42	CS35029001	1	上动刀 A	UPPER MOVABLE KNIFE, A	
43	CS37723101	1	<用于-02> 上动刀 B	<For -02> UPPER MOVABLE KNIFE, B	
44	C105288001	1	螺钉 SM2.38	SCREW SM2.38	
45	CS35410001	1	弯针 R	LOOPER, R	
46	CSA7547101	1	有孔弯针	EYE LOOPER	
47	CS35412101	1	右叉板 R	SPREADER, R	
48	CS35413101	1	左叉板 L	SPREADER, L	
49	CS35032101	2	螺钉 M2.6X5.5	SCREW, M2.6X5.5	
50	CS35034001	1	叉板定位 R	SPREADER STOPPER, R	
51	CS35033001	1	叉板定位 L	SPREADER STOPPER, L	
52	CS35032101	2	螺钉 M2.6X5.5	SCREW, M2.6X5.5	
53	CS37724001	1	<用于-02> 螺钉 SM2.38	<For -02> SCREW, SM2.38	
54	CS47932001	1	螺母 SM2.38-56	NUT, SM2.38-56	



L. 双链式弯针装置 / Double chain stitch looper mechanism

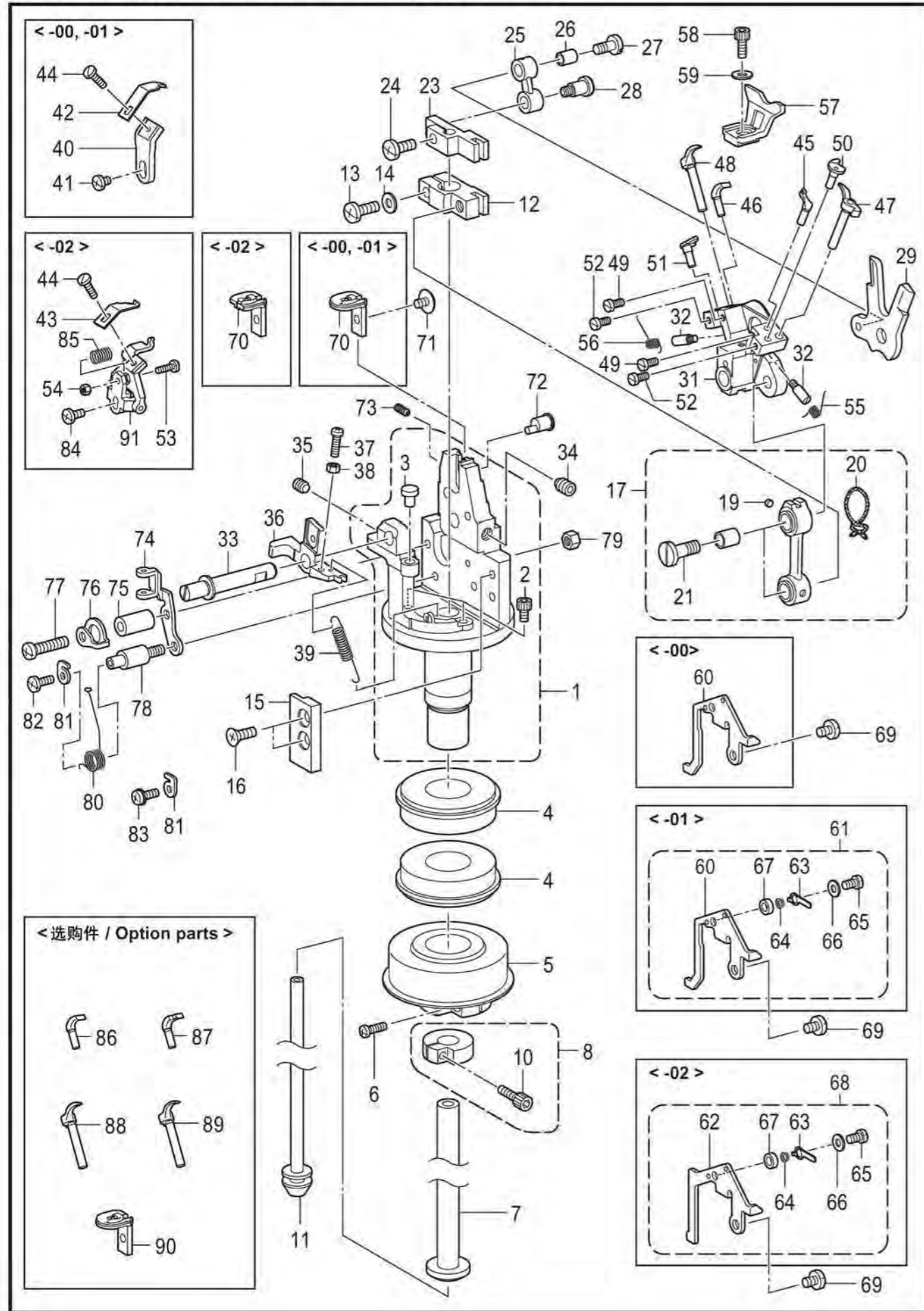

L. 双链式弯针装置 / Double chain stitch looper mechanism

参照号	零部件序号	数量	零部件名称	NAME OF PARTS	RM
55	CS35035101	1	叉板弹簧 R	SPRING, TWIST :R	
56	CS35036101	1	叉板弹簧 L	SPRING, TWIST :L	
57	CSA6872001	1	护针 U	NEEDLE GUARD U	
58	C 018300836	1	螺栓 M3X8	BOLT SOCKET M3X8	
59	C 025030136	1	平垫圈 S3	WASHER PLAIN S 3	
60	CSA7063001	1	<用于-00> 芯线导向 C	<For -00> GIMP THREAD GUIDE C	
61	CSA7578001	1	<用于-01> 芯线导向组件 C	<For -01> GIMP THREAD GUIDE C ASSY	
60	CSA7063001	1	芯线导向 C	GIMP THREAD GUIDE C	
63	CSA7613001	1	芯线压板	GIMP THREAD CLAMP PLATE	
64	CSA7614001	1	芯线调节弹簧	GIMP THREAD TENSION SPRING	
65	C 062300506	1	螺钉 M3X5	SCREW PAN M3X5	
66	C 025030236	1	平垫圈 M3	WASHER PLAIN M 3	
67	CSA7615001	1	管套 3	COLLAR 3	
68	CSA6873001	1	<用于-02> 芯线导向组件 C-J	<For -02> GIMP THREAD GUIDE C-J ASSY	
62	CSA6874001	1	芯线导向 C-J	GIMP THREAD GUIDE C-J	
63	CSA7613001	1	芯线压板	GIMP THREAD CLAMP PLATE	
64	CSA7614001	1	芯线调节弹簧	GIMP THREAD TENSION SPRING	
65	C 062300506	1	螺钉 M3X5	SCREW PAN M3X5	
66	C 025030236	1	平垫圈 M3	WASHER PLAIN M 3	
67	CSA7615001	1	管套 3	COLLAR 3	
69	C 060400516	1	螺钉 M4X5	SCREW BIND M4X5	
70	CSA7065001	1	<用于-00和-01> 针孔板 1.6	<For -00 & -01> THROAT PLATE 1.6	
70	CS37752001	1	<用于-02> 针孔板 1.8-J	<For -02> THROAT PLATE, 1.8-J	
71	CS35326101	1	螺钉 M3.5	SCREW M3.5	
72	CSA6875001	1	销	VERTICAL PIN	
73	C 014300832	1	螺钉 M3X8	SET SCREW SOCKET (CP) M3X8	
74	CSA6876001	1	底线导线板	THREAD GUIDE PLATE	
75	CSA6877001	1	管套	COLLAR	
76	CSA6878001	1	L夹线弹簧导向	L TR TAKE-UP SPRING SUPPORT	
77	C 062402016	1	螺钉 M4X20	SCREW PAN M4X20	
78	CSA6879001	1	弹簧导向轴	SPRING GUIDE SHAFT	
79	C 021400316	1	六角螺母 M4	NUT 3 M4	
80	CSA6880001	1	夹线弹簧	THREAD TAKE-UP SPRING	
81	CSA6881001	2	L夹线弹簧支撑	L TR TAKE-UP SPRING SUPPORT	
82	C 060300816	1	螺钉 M3X8	SCREW BIND M3X8	
83	C 0A4300805	1	螺栓(带垫圈) M3X8DA	SCREW PAN (S/P WASHER) M3X8	
84	C 060300816	1	<用于-02> 螺钉 M3X8	<For -02> SCREW BIND M3X8	
85	CS37725001	1	底线压簧	COMPRESSIONSPRING	
91	CSA6868101	1	底线压板组件 J	LOWER THREAD PRESSER J ASSY	
86	CSA7634101	1	<选购件> 有孔弯针 B	<Option parts> EYE LOOPER, B	
87	CS49078001	1	弯针 L-S	LOOPER, L-S	
88	CS35472101	1	叉板 LB	SPREADER, LB	
89	CS49079001	1	叉板 L-S	SPREADER, L-S	
90	CSA7546001	1	针孔板 1.1	THROAT PLATE, 1.1	



M. 分纱装置 / Spreader mechanism

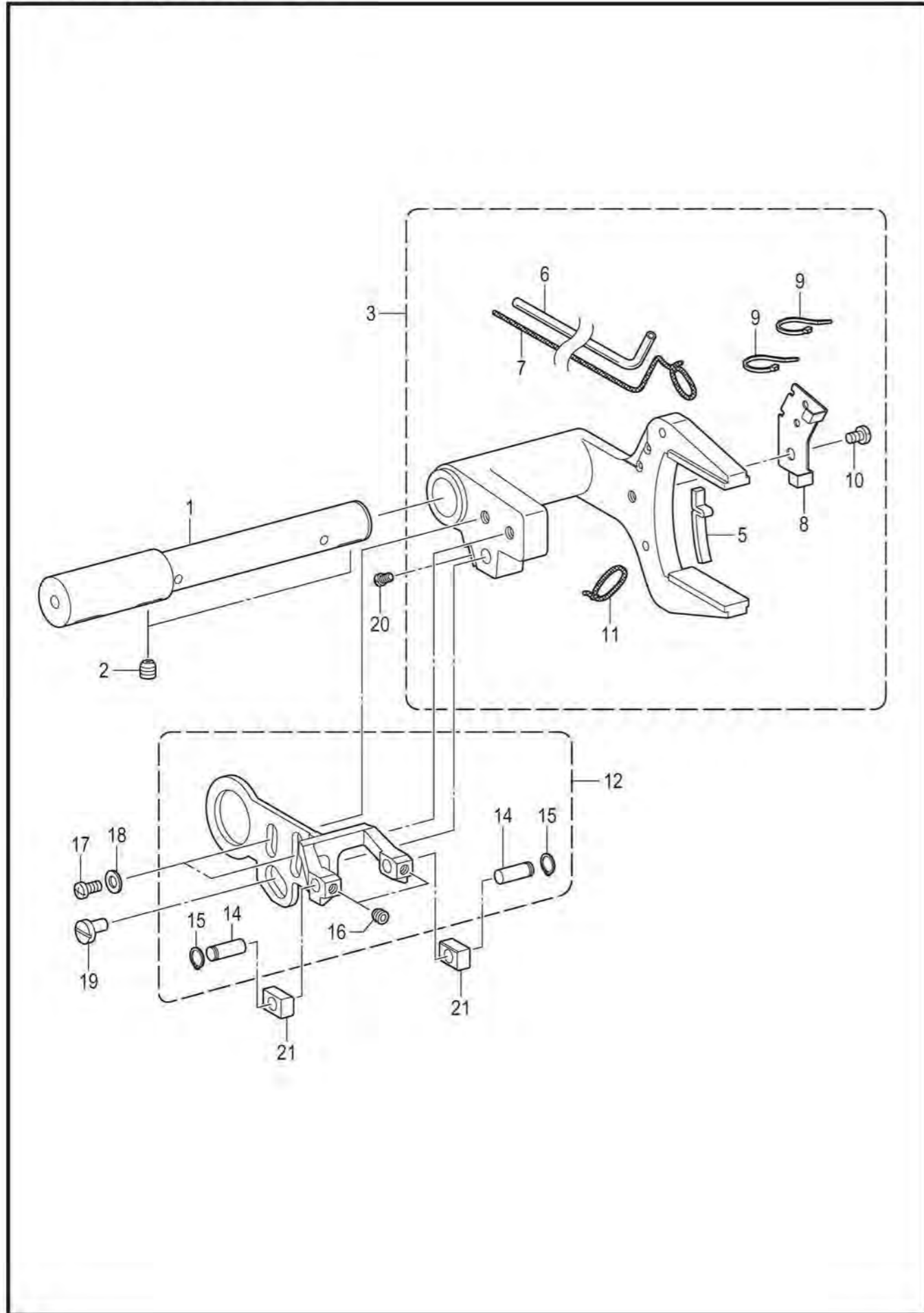

M. 分纱装置 / Spreader mechanism

参照号	零部件序号	数量	零部件名称	NAME OF PARTS	RM
1	CSA6882001	1	叉板杆轴	SPREADER LEVER SHAFT	
2	C014500836	2	螺钉 M5X8	SET SCREW SOCKET (CP) M5X8	
3	CSA6883101	1	叉板杆组件 A	SPREADER LEVER A ASSY	
5	CSA6885001	1	油毡	SPREADER LEVER FELT	
6	CSA5565001	1	油管	OIL TUBE	
7	CSA6886001	1	油线 2X2	WICK 2X2	
8	CSA6887001	1	油管压板	SPREADER TUBE CLAMP	
9	C228475000	2	电线夹 1.9X80	FASTENING BAND 1.9X80	
10	C060400516	1	螺钉 M4X5	SCREW BIND M4X5	
11	CSA8001001	1	油线 2X2	WICK 2X2	
12	CSA6888001	1	叉板杆组件 B	SPREADER LEVER B ASSY	
14	CSA6890001	2	轴 6X15.5	SHAFT 6X15.5	
15	C048060142	2	轴用挡圈 C6	RETAINING RING EXTERNAL C6	
16	C012500536	2	螺钉 M5X5	SET SCREW SOCKET (FT) M5X5	
17	C062400816	2	螺钉 M4X8	SCREW PAN M4X8	
18	C025040236	2	平垫圈 M4	WASHER PLAIN M 4	
19	CSA6891001	1	偏心销	ECCENTRIC PIN	
20	CS25279101	1	螺钉 M3.5-5	SET SCREW (CP) M3.5-5	
21	CSA6892001	2	角块 6X8	SLIDE BLOCK 6X8	



N. 供油润滑装置 / Lubrication

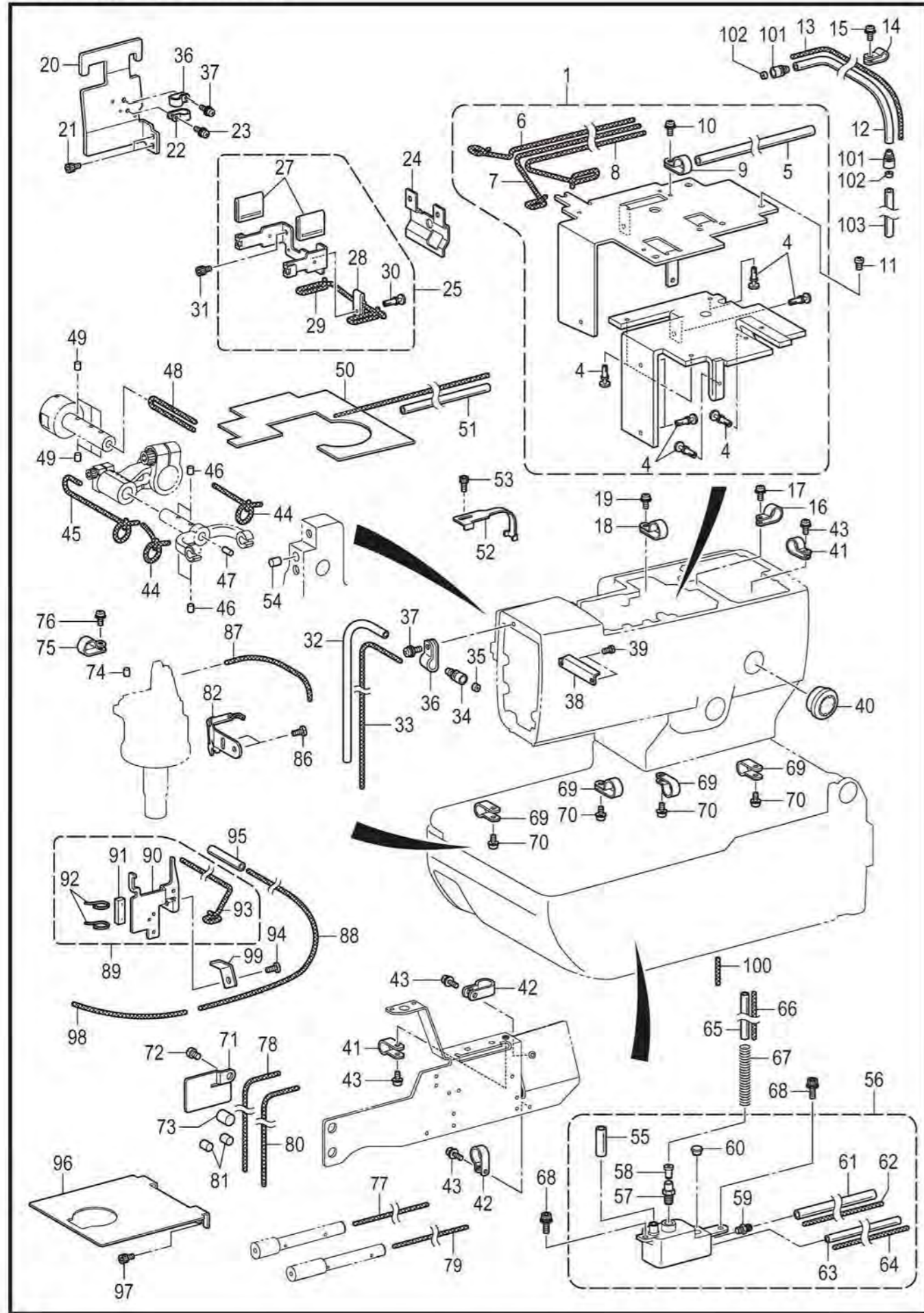

N. 供油润滑装置 / Lubrication

参照号	零部件序号	数量	零部件名称	NAME OF PARTS	RM
1	CSA6893001	1	油板组件	OIL PLATE ASSY	
4	CS35001000	8	尼龙铆钉	NYLON RIVET	
5	CSA6896001	1	油管	OIL TUBE	
6	CSA6897001	1	油线 3X3	WICK 3X3	
7	CSA6898001	1	油线 3X3	WICK 3X3	
8	CSA6899001	1	油线 6X6	WICK 6X6	
9	CS00480000	1	电线夹 #5	CORD HOLDER, 5N	
10	COA4400806	1	螺栓(带垫圈) M4X8DA	SCREW PAN (S/P WASHER) M4X8	
11	C062400816	4	螺钉 M4X8	SCREW PAN M4X8	
12	CSA6900001	1	油管	OIL TUBE	
13	CSA6901101	1	油线 3X3	WICK 3X3	
14	C146202000	1	尼龙线夹 6N	CORD HOLDER, 6N	
15	COA4400806	1	螺栓(带垫圈) M4X8DA	SCREW PAN (S/P WASHER) M4X8	
16	CS10243000	1	尼龙夹 NK-3N	CORD HOLDER, NK-3N	
17	COA4400806	1	螺栓(带垫圈) M4X8DA	SCREW PAN (S/P WASHER) M4X8	
18	C149547000	1	压线板	CORD HOLDER, 4N	
19	COA4400806	1	螺栓(带垫圈) M4X8DA	SCREW PAN (S/P WASHER) M4X8	
20	CSA6902001	1	油管压板	TUBE SUPPORT	
21	C018400636	2	螺栓 M4X6	BOLT SOCKET M4X6	
22	CS10243000	1	尼龙夹 NK-3N	CORD HOLDER, NK-3N	
23	COA4400806	1	螺栓(带垫圈) M4X8DA	SCREW PAN (S/P WASHER) M4X8	
24	CSA6903001	1	挡油板	OIL STOPPER	
25	CSA6904001	1	油毡压板组件	FELT HOLDER ASSY	
27	CSA6906001	2	针杆油毡	N-BAR YOKE FELT	
28	CSA6907001	1	角块供油毡 D	SLIDE BLOCK FELT D	
29	CSA6908001	1	油线 2X2	WICK 2X2	
30	CS35001000	1	尼龙铆钉	NYLON RIVET	
31	C018400636	2	螺栓 M4X6	BOLT SOCKET M4X6	
32	CSA6909001	1	油管	OIL TUBE	
33	CSA6910001	1	油线 2X2	WICK 2X2	
34	CS56911000	1	油管接头 S	OIL JOINT S	
35	CS51020000	1	油芯紧圈	COLLAR	
36	CS10243000	2	尼龙夹 NK-3N	CORD HOLDER, NK-3N	
37	COA4400806	2	螺栓(带垫圈) M4X8DA	SCREW PAN (S/P WASHER) M4X8	
38	CSA6911001	1	油板	OIL PLATE	
39	C062400616	2	螺钉 M4X6	SCREW PAN M4X6	
40	CS49992000	1	油视窗	OIL GAUGE WINDOW	
41	CS00480000	2	电线夹 #5	CORD HOLDER, 5N	
42	C552907000	2	电线夹 #10	CORD HOLDER #10	
43	COA4400806	4	螺栓(带垫圈) M4X8DA	SCREW PAN (S/P WASHER) M4X8	
44	CSA6912001	2	油线 2X2	WICK 2X2	
45	CSA6913001	1	油线 2X2	WICK 2X2	
46	CS29700000	4	上弯针导向油毡	FELT	
47	C153050000	1	油毡	S-RACE BASE FELT	
48	CSA6914001	1	油线 2X2	WICK 2X2	
49	CS29700000	6	上弯针导向油毡	FELT	
50	CSA6915001	1	油毡组件	FELT ASSY	
51	CSA6918001	1	油管	OIL TUBE	
52	CSA6919001	1	油管压板	TUBE GUIDE	
53	C018400836	1	螺栓 M4X8	BOLT SOCKET M4X8	
54	CS25328001	1	油毡	FELT	
55	CSA8279001	1	油管	OIL TUBE	
56	CSA6920001	1	副油罐总组件	SUB-TANK UNIT	
57	CSA3040001	1	油嘴管	OIL FEEDING PIPE	
58	CSA3060001	1	油门垫片	VALVE PACKING	
59	CSA6922001	1	油口 6.5-3.8	OIL CONNECROR 6.5-3.8	
60	C104450101	1	橡皮塞 8	RUBBER CAP, 8	
61	CSA6923001	1	油管	OIL TUBE	
62	CSA6924001	1	油线 6X6	WICK 6X6	
63	CSA6925001	1	油管	OIL TUBE	
64	CSA6926001	1	油线 3X3	WICK 3X3	
65	CSA6927001	1	油管	OIL TUBE	
66	CSA6928001	1	油线 6X6	WICK 6X6	



N. 供油润滑装置 / Lubrication

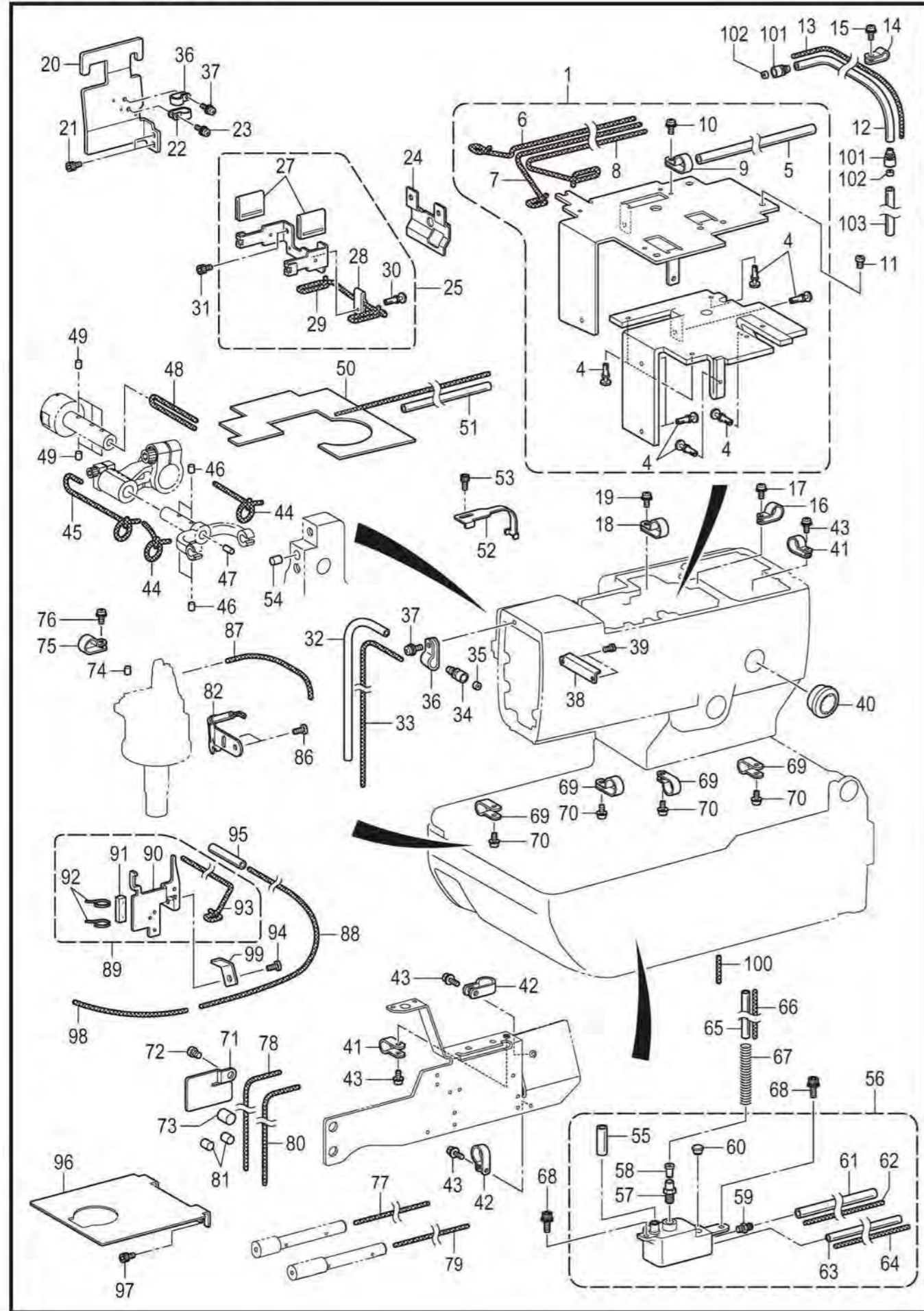

N. 供油润滑装置 / Lubrication

参照号	零部件序号	数量	零部件名称	NAME OF PARTS	RM
67	CSA6929001	1	油管定位弹簧	TUBE CLIP SPRING	
68	CS55481001	2	螺栓(带垫圈) M4X12	BOLT SOCKET (S/P WASHER)M4X12	
69	C 149287000	4	压线板	CORD HOLDER, 7N	
70	C0A4400806	4	螺栓(带垫圈) M4X8DA	SCREW PAN (S/P WASHER) M4X8	
71	CSA6930001	1	油管压板 B	TUBE SUPPORT B	
72	C 062500816	1	螺钉 M5X8	SCREW PAN M5X8	
73	CS25328001	1	油毡	FELT	
74	C 112753001	1	油毡	FELT	
75	CS00480000	1	电线夹 #5	CORD HOLDER, 5N	
76	C0A4400806	1	螺栓(带垫圈) M4X8DA	SCREW PAN (S/P WASHER) M4X8	
77	CSA6886001	1	油线 2X2	WICK 2X2	
78	CSA5567001	1	油线 2X2	WICK 2X2	
79	CSA5566001	1	油线 2X2	WICK 2X2	
80	CSA5567001	1	油线 2X2	WICK 2X2	
81	C 107155001	2	油毡	FELT	
82	CSA6932001	1	弯针座供油组件	LOOPER BASE OIL PLATE ASSY	
86	C 060400516	2	螺钉 M4X5	SCREW BIND M4X5	
87	CSA6936001	1	油线	WICK	
88	CSA6937101	1	油线 2X2	WICK 2X2	
89	CSA6938001	1	芯线板组件	GIMP THREAD WASTE PLATE ASSY	
90	CSA6939001	1	芯线板	GIMP THREAD WASTE PLATE	
91	CSA6940001	1	弯针油毡	LOOPER LINK FELT	
92	C 228475000	2	电线夹 1.9X80	FASTENING BAND 1.9X80	
93	CSA6941001	1	油线 2X2	WICK 2X2	
94	C 060400816	1	螺钉 M4X8	SCREW BIND M4X8	
95	CSA7178001	1	油管	OIL TUBE	
96	CSA6942001	1	隔板	PARTITION	
97	C 018400636	2	螺栓 M4X6	BOLT SOCKET M4X6	
98	CSA8009001	1	油线	WICK	
99	CS02657101	1	油线夹板	CORD HOLDER	
100	CSA8011001	1	油线 6X6	WICK 6X6	
101	CS56911000	2	油管接头 S	OIL JOINT S	
102	CS51020000	2	油芯紧圈	COLLAR	
103	CSA8101001	1	油管	OIL TUBE	



P1. 穿线装置 / Threading mechanism

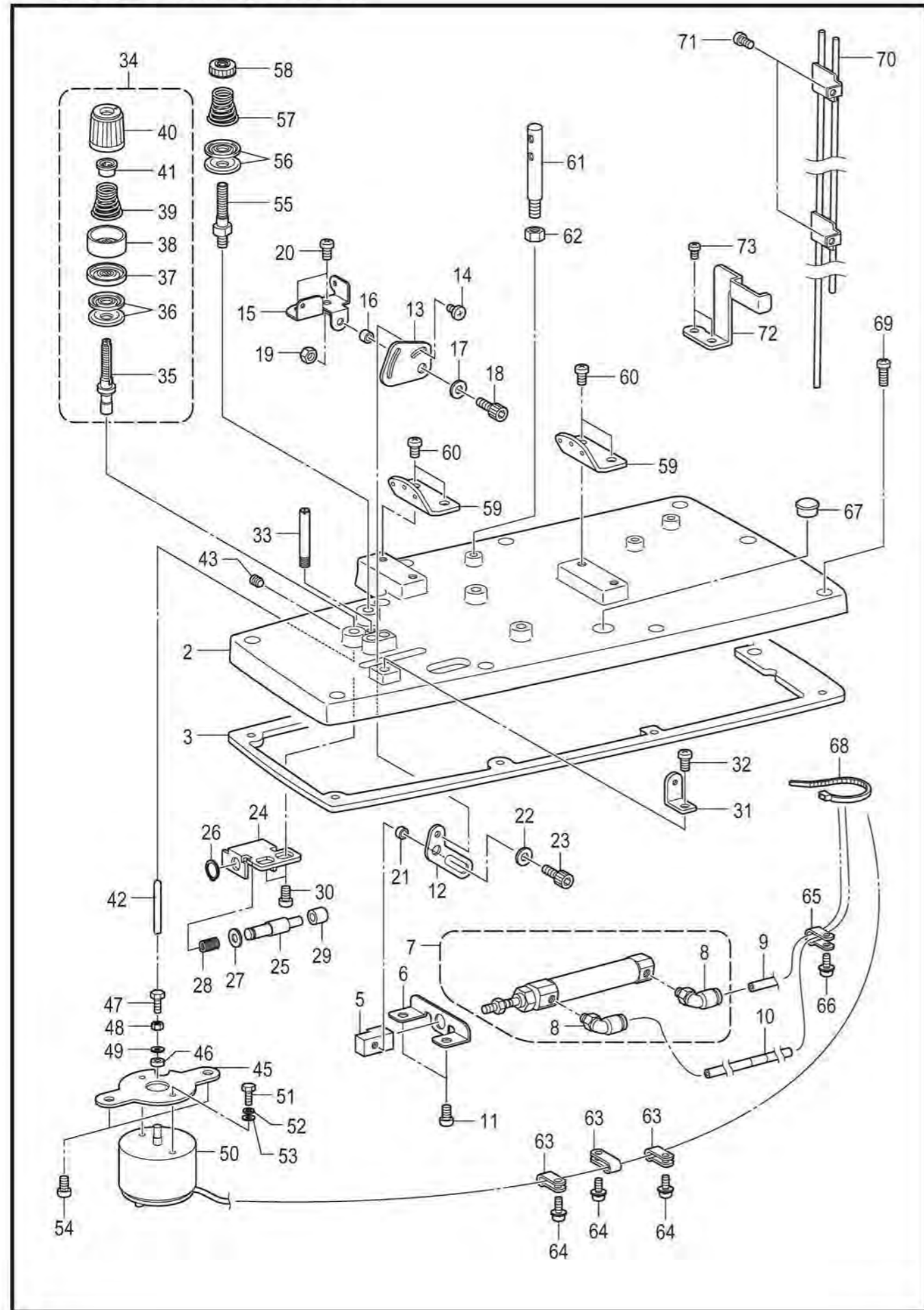

P1. 穿线装置 / Threading mechanism

参照号	零部件序号	数量	零部件名称	NAME OF PARTS	RM
2	CSA6944001	1	上盖	TOP COVER	
3	CSA6945001	1	上盖垫片	PACKING TOP COVER	
5	CSA6947101	1	气缸接头 A	CYLINDER JOINT A	
6	CSA6948101	1	气缸安装板 A	CYLINDER SETTING PLATE A	
7	CSA6949001	1	气缸组件 10-30	CYLINDER ASSY 10-30	
8	CS11426000	2	弯管接头 4M5	ELBOW UNION 4M5	
9	CSA6950001	1	空气管 4X2.5-11	AIR TUBE 4X2.5-11	
10	CSA7134001	1	空气管 4X2.5-12	AIR TUBE 4X2.5-12	
11	C062500816	2	螺钉 M5X8	SCREW PAN M5X8	
12	CSA6951001	1	取线手杆驱动板	T-TAKE-UP LEVER DRIVING PLATE	
13	CSA6952001	1	取线手杆板	THREAD TAKE-UP LEVER PLATE	
14	C060400516	1	螺钉 M4X5	SCREW BIND M4X5	
15	CSA6953001	1	取线手杆基台	THREAD TAKE-UP LEVER BASE	
16	CSA6954001	1	管套 A	COLLAR A	
17	CSA7494001	1	垫圈	WASHER	
18	C018401036	1	螺栓 M4X10	BOLT SOCKET M4X10	
19	C021400206	1	六角螺母 M4	NUT 2 M4	
20	C062500816	2	螺钉 M5X8	SCREW PAN M5X8	
21	CSA6955001	1	管套 B	COLLAR B	
22	CSA7494001	1	垫圈	WASHER	
23	C018401036	1	螺栓 M4X10	BOLT SOCKET M4X10	
24	CSA6956101	1	冲击支撑板	IMPACT SUPPORT PLATE	
25	CSA6957001	1	冲击支撑杆	IMPACT SUPPORT SHAFT	
26	C048060142	1	轴用挡圈 C6	RETAINING RING EXTERNAL C6	
27	C025060236	1	平垫圈 M6	WASHER PLAIN M 6	
28	CSA6958001	1	压簧 A	SPRING COMPRESSION A	
29	CS05356000	1	扣夹 A	BUTTON CLAMP, A	
30	C062500816	2	螺钉 M5X8	SCREW PAN M5X8	
31	CSA6959001	1	面线导向 A	UPPER THREAD GUIDE A	
32	C062500816	1	螺钉 M5X8	SCREW PAN M5X8	
33	CSA6960101	1	线导向杆 A	THREAD GUIDE ROD A	
34	CSA6961001	1	夹线器组件 U	TENSION U ASSY	
35	CSA6962001	1	夹线螺杆 U	TENSION STUD U	
36	C145446001	2	夹线盘	DISC, TENSION	
37	C159805001	1	夹线压盘	TENSION DISC PRESSER	
38	C144103009	1	压线圈	TENSION DISC PRESSER	
39	C159221101	1	调节弹簧	TENSION SPRING	
40	CS20682102	1	调节螺母	TENSION NUT	
41	CS20681000	1	调节弹簧垫圈	WASHER	
42	C152873001	1	松线销	TENSION RELEASE PIN	
43	C012500536	1	螺钉 M5X5	SET SCREW SOCKET (FT) M5X5	
45	CSA3345001	1	电磁铁安装板	SETTING PLATE, SOLENOID	
46	C154599000	1	电磁铁缓冲垫圈	SOLENOID CUSHION	
47	C017401415	1	螺栓 M4X14	BOLT M4X14	
48	C021400306	1	六角螺母 M4	NUT 3 M4	
49	C102707002	1	垫圈 4	WASHER	
50	CSA6538001	1	面线松线电磁铁	U-TENSION RELEASE SOLENOID	
51	C017400802	2	螺栓 M4X8	BOLT M4X8	
52	C028040246	2	弹簧垫圈 2-4	WASHER SPRING 2-4	
53	C025040236	2	平垫圈 M4	WASHER PLAIN M 4	
54	C062500816	2	螺钉 M5X8	SCREW PAN M5X8	
55	CS20698221	1	夹线螺杆	TENSION STUD	
56	C144504001	2	导向盘	THREAD GUIDE DISC	
57	C154562101	1	小夹线弹簧 B	PRE-TENSION SPRING B	
58	C155510001	1	夹线螺母	TENSION NUT	
59	CSA6963001	2	三眼导线板	SEWING THREAD RETAINER GUIDE	
60	C062500816	4	螺钉 M5X8	SCREW PAN M5X8	
61	CSA5568001	1	穿线杆	THREAD SPOOL PIN	
62	C021500216	1	六角螺母 M5	NUT 1 M5	
63	C149547000	3	压线板	CORD HOLDER, 4N	
64	C0A4400806	3	螺栓(带垫圈) M4X8DA	SCREW PAN (S/P WASHER) M4X8	
65	CS00480000	1	电线夹 #5	CORD HOLDER, 5N	
66	C0A4400806	1	螺栓(带垫圈) M4X8DA	SCREW PAN (S/P WASHER) M4X8	



P1. 穿线装置 / Threading mechanism

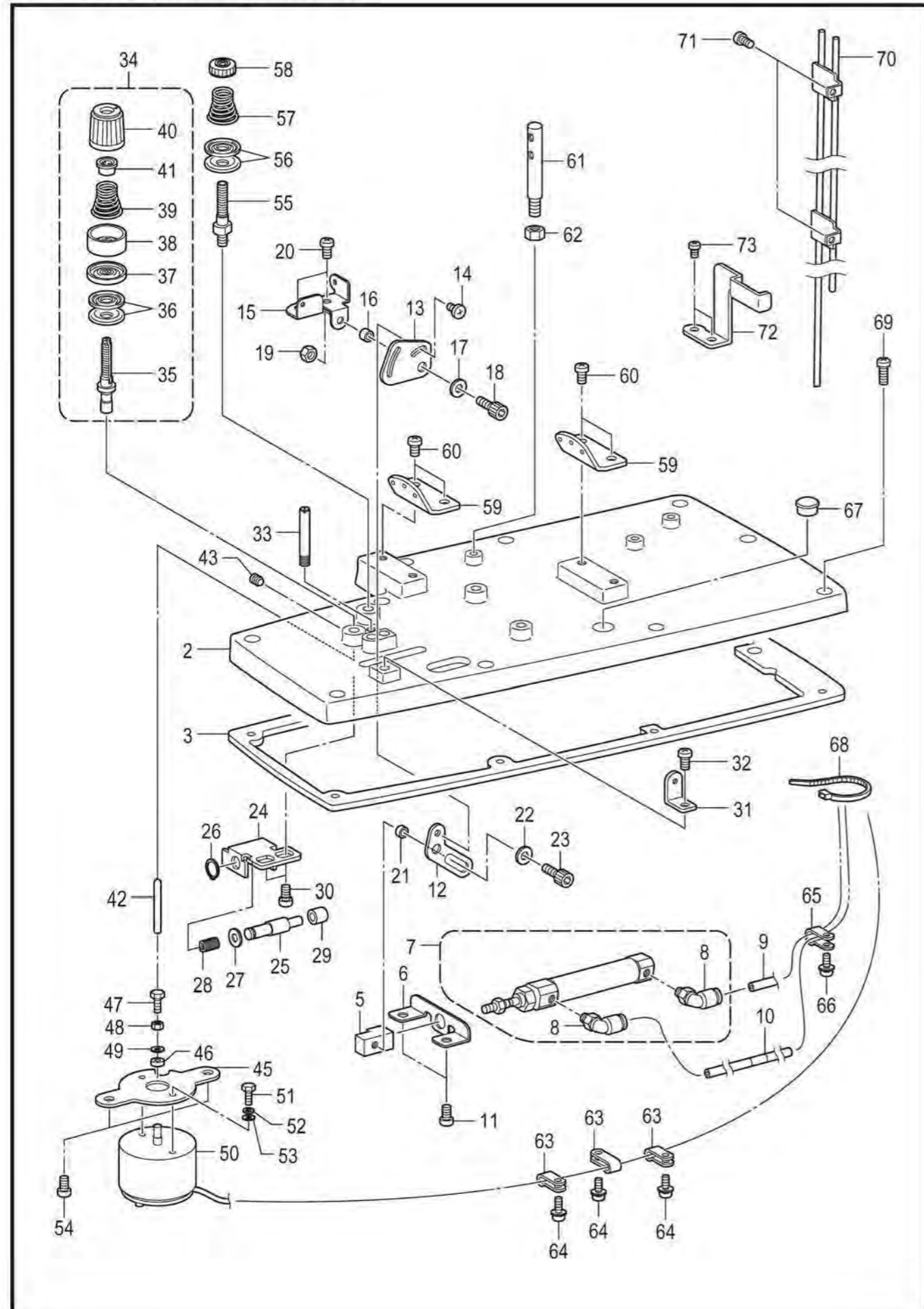

P1. 穿线装置 / Threading mechanism

参照号	零部件序号	数量	零部件名称	NAME OF PARTS	RM
67	C 104821001	1	橡皮塞 10.5	RUBBER CAP, 10.5	
68	C 228475000	1	电线夹 1.9X80	FASTENING BAND 1.9X80	
69	C 062501216	9	螺钉 M5X12	SCREW PAN M5X12	
70	CSA6965001	1	2连线导向管	2 PEDAL THREAD GUIDE PIPE	
71	C 062500816	2	螺钉 M5X8	SCREW PAN M5X8	
72	CSA6966001	1	导向管基座	PIPE CLAMP PLATE	
73	C 062400816	2	螺钉 M4X8	SCREW PAN M4X8	



P2. 穿线装置 / Threading mechanism

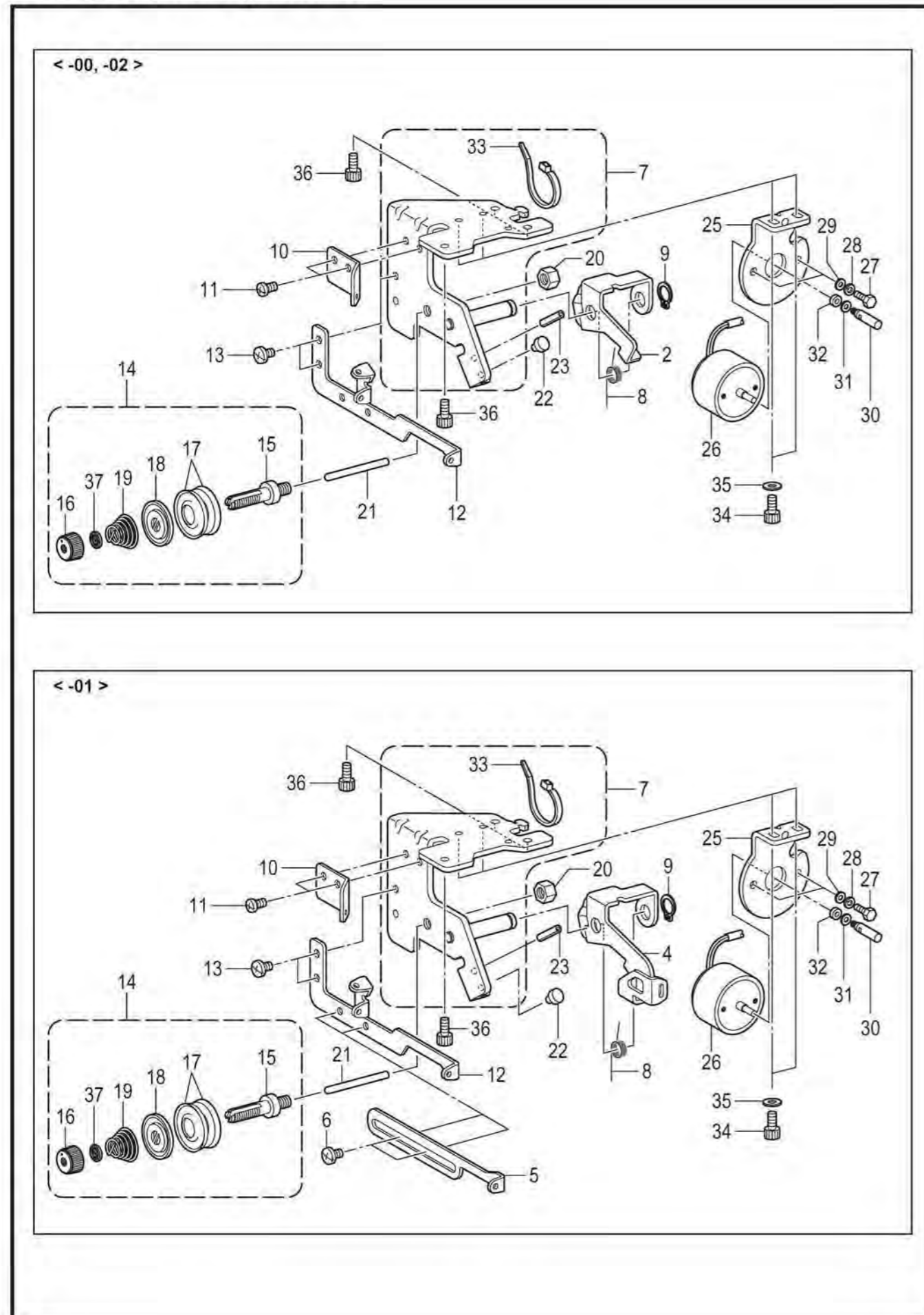

P2. 穿线装置 / Threading mechanism

参照号	零部件序号	数量	零部件名称	NAME OF PARTS	RM
2	CSA7067101	1	<用于-00和-02> 底线松线板	<For -00 & -02> L-THREAD RELEASE PLATE	
4	CSA6971001	1	<用于-01> 底线取线手柄	<For -01> L-THREAD TAKE-UP GUIDE LENER	
5	CSA6974001	1	底线导向 C	LOWER THREAD GUIDE C	
6	C060400516	2	螺钉 M4X5	SCREW BIND M4X5	
7	CSA6969101	1	底线调节板	L-THREAD GUIDE ADJUST PLATE	
8	CSA6970001	1	弹簧 B	TWIST SPRING B	
9	C048080142	1	轴用挡圈 C8	RETAINING RING EXTERNAL C8	
10	CSA6972001	1	底线导向 A	LOWER THREAD GUIDE A	
11	C062400816	2	螺钉 M4X8	SCREW PAN M4X8	
12	CSA6973001	1	底线导向 B	LOWER THREAD GUIDE B	
13	C060400516	2	螺钉 M4X5	SCREW BIND M4X5	
14	CSA7175201	1	底线夹线杆组件	L-THREAD TENSION SHAFT ASSY	
15	CSA6975101	1	底线夹线杆 D	TENSION STUD D	
16	CSA8094001	1	调节螺母	TENSION NUT	
17	C145446001	2	夹线盘	DISC, TENSION	
18	C159805001	1	夹线压盘	TENSION DISC PRESSER	
19	C154562101	1	小夹线弹簧 B	PRE-TENSION SPRING B	
20	CSA3227001	1	螺母 M6	NUT(FT),M6	
21	CSA6977001	1	松线销	TENSION RELEASE PIN	
22	CS52431000	1	剪刀定位	U-THREAD TRIMMER STOPPER	
23	C047301042	1	弹簧销 AW3	PIN SPRING ROLL AW3	
25	CSA6979001	1	松线电磁铁安装板	LOWER SOLENOID SETTING PLATE	
26	CSA6539001	1	松线电磁铁	L-TENSION RELEASE SOLENOID	
27	C017400802	2	螺栓 M4X8	BOLT M4X8	
28	C028040246	2	弹簧垫圈 2-4	WASHER SPRING 2-4	
29	C025040236	2	平垫圈 M4	WASHER PLAIN M 4	
30	CSA6980001	1	电磁铁轴	LOWER SOLENOID SHAFT	
31	C155559001	1	平垫圈	WASHER PLAIN	
32	C154599000	1	电磁铁缓冲垫圈	SOLENOID CUSHION	
33	CS04159000	1	线夹 1M	BAND, 1M	
34	C018400836	2	螺栓 M4X8	BOLT SOCKET M4X8	
35	C026040136	2	平垫圈 S4	WASHER PLAIN S 4	
36	C018400836	3	螺栓 M4X8	BOLT SOCKET M4X8	
37	CSA8095001	1	垫圈	WASHER	



< -01用于芯线 / For -01 gimp thread >

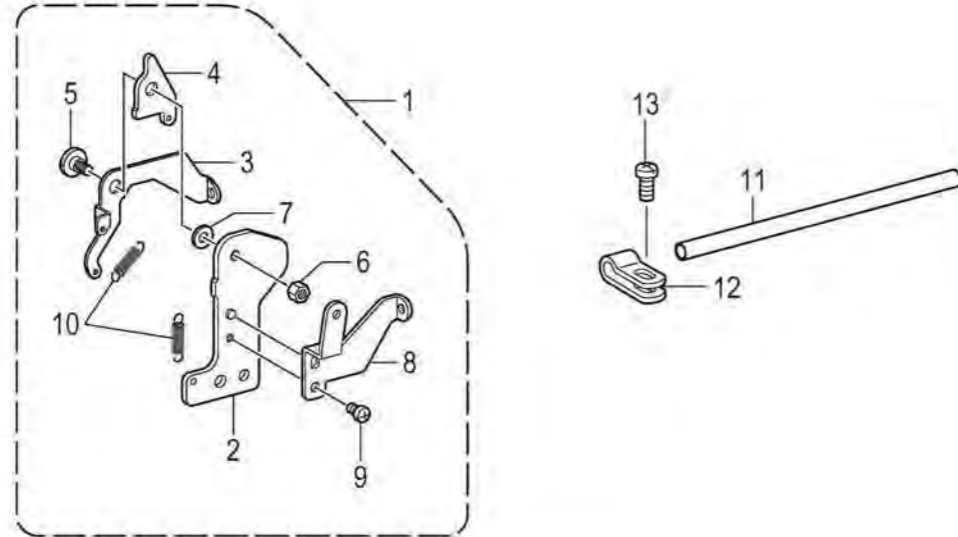

< -00, -02用于芯线 / For -00 & -02 gimp thread >

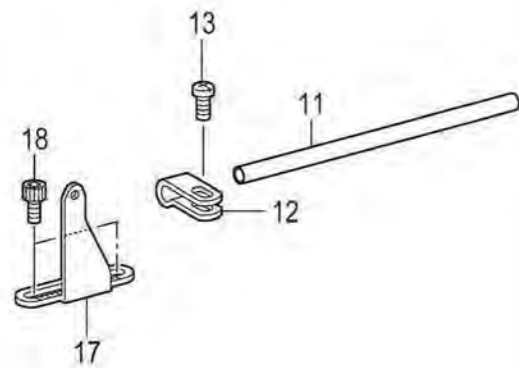

< 用于底线 / For lower thread >

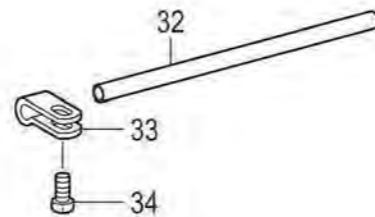

< -02用于芯线 / For -02 gimp thread >

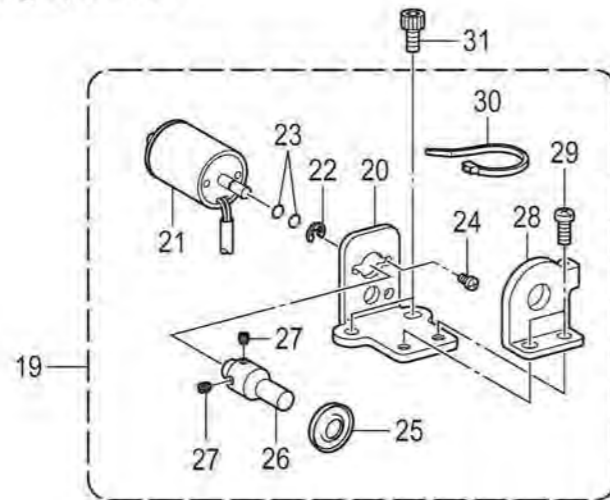

参照号	零部件序号	数量	零部件名称	NAME OF PARTS	RM
1	CSA7068001	1	<-01用于芯线> 芯线过线手柄组件	<For -01 gimp thread> GIMP THREAD TAKE-UP G-L ASSY	
2	CSA7069001	1	芯线过线架	GIMP THREAD TAKE-UP G-HOLDER	
3	CSA7070001	1	芯线过线板	G-THREAD TAKE-UP GUIDE PLATE	
4	CSA7071001	1	芯线过线作动板	GIMP THREAD TAKE-UP G-E PLATE	
5	CSA7072001	1	段螺钉 M4	SHOULDER SCREW M4	
6	C021400306	1	六角螺母 M4	NUT 3 M4	
7	C158722001	1	垫圈 4.2	WASHER PLAIN 4.2	
8	CSA7073001	1	芯线导向	GIMP THREAD GUIDE	
9	C062300416	1	螺钉 M3X4	SCREW PAN M3X4	
10	CSA7074001	2	弹簧	SPRING TORSION	
11	CSA6981001	1	芯线导向管	GIMP THREAD GUIDE PIPE	
12	CS20696001	1	导线管夹	THREAD GUIDE PIPE SUPPORT	
13	C062400816	1	螺钉 M4X8	SCREW PAN M4X8	
11	CSA6981001	1	<-00和02用于芯线> 芯线导向管	<For -00 & -02 gimp thread> GIMP THREAD GUIDE PIPE	
12	CS20696001	1	导线管夹	THREAD GUIDE PIPE SUPPORT	
13	C062400816	1	螺钉 M4X8	SCREW PAN M4X8	
17	CSA6982001	1	芯线导向 J	GIMP THREAD GUIDE J	
18	C018400836	2	螺栓 M4X8	BOLT SOCKET M4X8	
19	CSA6983101	1	<-02用于芯线> 芯线夹组件	<For -02 gimp thread> GIMP THREAD CLAMP ASSY	
20	CSA6984001	1	芯线夹板	GIMP THREAD CLAMP PLATE	
21	CSA6537001	1	芯线电磁铁	GIMP THREAD SOLENOID	
22	C048025346	1	挡圈 E2.5	RETAINING RING E2.5	
23	C081003870	2	O形圈 S3	O RING S3	
24	C062260406	2	螺钉 M2.6X4	SCREW PAN M2.6X4	
25	C145446002	1	夹线盘	DISC, TENSION	
26	CSA6986101	1	芯线轴	GIMP THREAD SHAFT	
27	C014300332	2	螺钉 M3X3	SET SCREW SOCKET (CP) M3X3	
28	CSA6987001	1	芯线夹	GIMP THREAD CLAMP	
29	C062400816	2	螺钉 M4X8	SCREW PAN M4X8	
30	CS04557000	1	电线夹 PLT1M	BAND, PLT1M	
31	C018400836	2	螺栓 M4X8	BOLT SOCKET M4X8	
32	CSA6981001	1	<用于底线> 芯线导向管	<For lower thread> GIMP THREAD GUIDE PIPE	
33	CS20696001	1	导线管夹	THREAD GUIDE PIPE SUPPORT	
34	C062400816	1	螺钉 M4X8	SCREW PAN M4X8	



Q1. 切线装置 / Thread trimmer mechanism

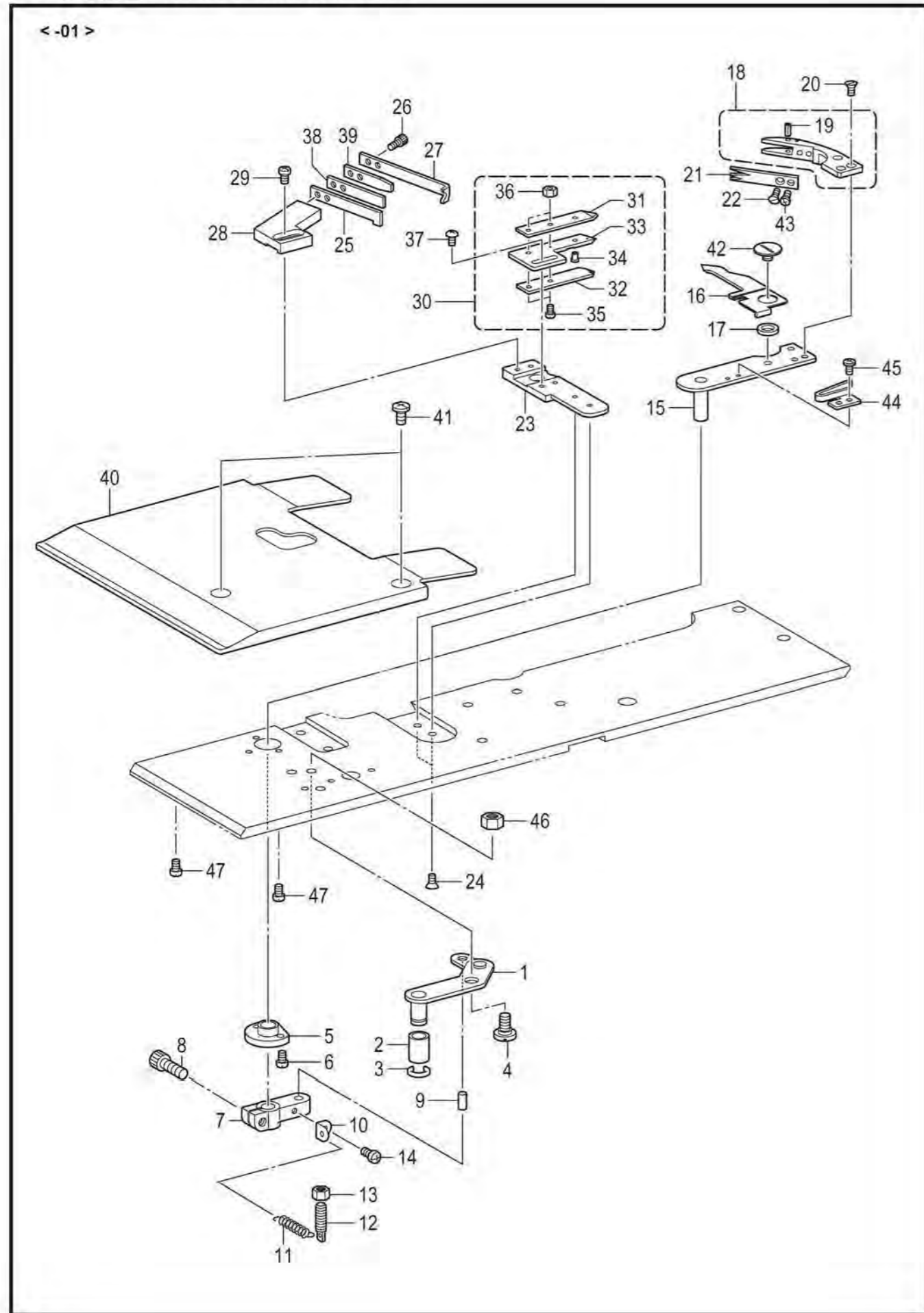

Q1. 切线装置 / Thread trimmer mechanism

参照号	零部件序号	数量	零部件名称	NAME OF PARTS	RM
			<用于-01>	<For -01>	
1	CSA7526001	1	切线连接杆组件	THREAD TRIMMER LINK LEVER ASSY	
2	CSA7778001	1	连接杆滚轮	LINK LEVER ROLLER	
3	C137191051	1	挡圈	STOP RING	
4	CSA5693001	1	段螺钉 M4	SHOULDER SCREW M4	
5	CS34906100	1	切线臂管套	BUSH TR TRIMMER ARM	
6	C062260516	2	螺钉 M2.6X5	SCREW PAN M2.6X5	
7	CS34905101	1	切线杆臂	THREAD CUTTER LEVER ARM	
8	C018401036	1	螺栓 M4X10	BOLT SOCKET M4X10	
9	CS37858000	1	针销 4X8	NEEDLE PIN, 4X8	
10	CS34903001	1	弹簧挂钩	SPRING HOOK	
11	CS34883001	1	切线弹簧	SPRING, EXTENSION	
12	CS34902001	1	弹簧挂钩	SPRING HOOK	
13	C021350106	1	螺母 M3.5	NUT 1 M3.5	
14	C062260516	1	螺钉 M2.6X5	SCREW PAN M2.6X5	
15	CS34901001	1	切线臂	THREAD TRIMMER ARM	
16	CS34900001	1	分线板	OPENER, ;T-NIPPER	
17	C153219001	1	动刀管套	COLLAR, ;MOVABLE KNIFE	
18	CS34899001	1	动刀组件	MOVABLE KNIFE ASSY	
19	CS34898001	1	弹簧销 1.4	PIN, SPRING 1.4	
20	C141542001	3	螺钉 3.18	SCREW 3.18	
21	CSA7076001	1	挡线器	THREAD HANDLER	
22	CS01694001	1	螺钉 SM2.38X4	SCREW, FLAT SM2.38X4	
23	CS34896001	1	定刀台座	BRACKET, ;FIXED KNIFE	
24	C061300416	2	螺钉 M3X4	SCREW FLAT M3X4	
25	CS34895001	1	定刀	FIXED KNIFE	
26	C018260832	2	螺栓 M2.6X8	BOLT, SOCKET M2.6X8	
27	CS34894001	1	线导向板	THREAD GUIDE PLATE	
28	CS34893001	1	定刀安装板	SETTING BRACKET FIXED KNIFE	
29	C062300512	2	螺钉 M3X5	SCREW PAN M3X5	
30	CS34889101	1	夹线组件	THREAD NIPPER ASSY	
31	CS34890001	1	夹线 U	THREAD NIPPER, U	
32	CS34891101	1	夹线 D	THREAD NIPPER, D	
33	CS34888101	1	夹线 M	THREAD NIPPER, M	
34	CS34892001	1	分线销	OPENER PIN	
35	C062020416	2	螺钉 M2X4	SCREW PAN M2X4	
36	C021020106	2	螺母 M2	NUT 1 M2	
37	C542515001	2	螺母 M2.6X3.5	SCREW M2.6X3.5	
38	CS34887001	1	定刀板弹簧	SPRING, PLATE ;F-KNIFE	
39	CS34886001	1	定刀板弹簧 U	SPRING, U PLATE ;F-KNIFE	
40	CSA7077001	1	压板 U	PRESSER PLATE U	
41	C060400516	2	螺钉 M4X5	SCREW BIND M4X5	
42	C152904001	1	螺钉 SM4.37	SCREW, SM4.37	
43	C104336003	1	螺钉 SM2.38	SCREW, SM2.38	
44	CS34884000	1	分线器弹簧	OPENER SPRING	
45	C060630312	2	螺钉 SM2.38-56X3	SCREW BIND SM2.38-56X3	
46	C021400306	1	六角螺母 M4	NUT 3 M4	
47	C062300416	2	螺钉 M3X4	SCREW PAN M3X4	



Q2. 切线装置 / Thread trimmer mechanism

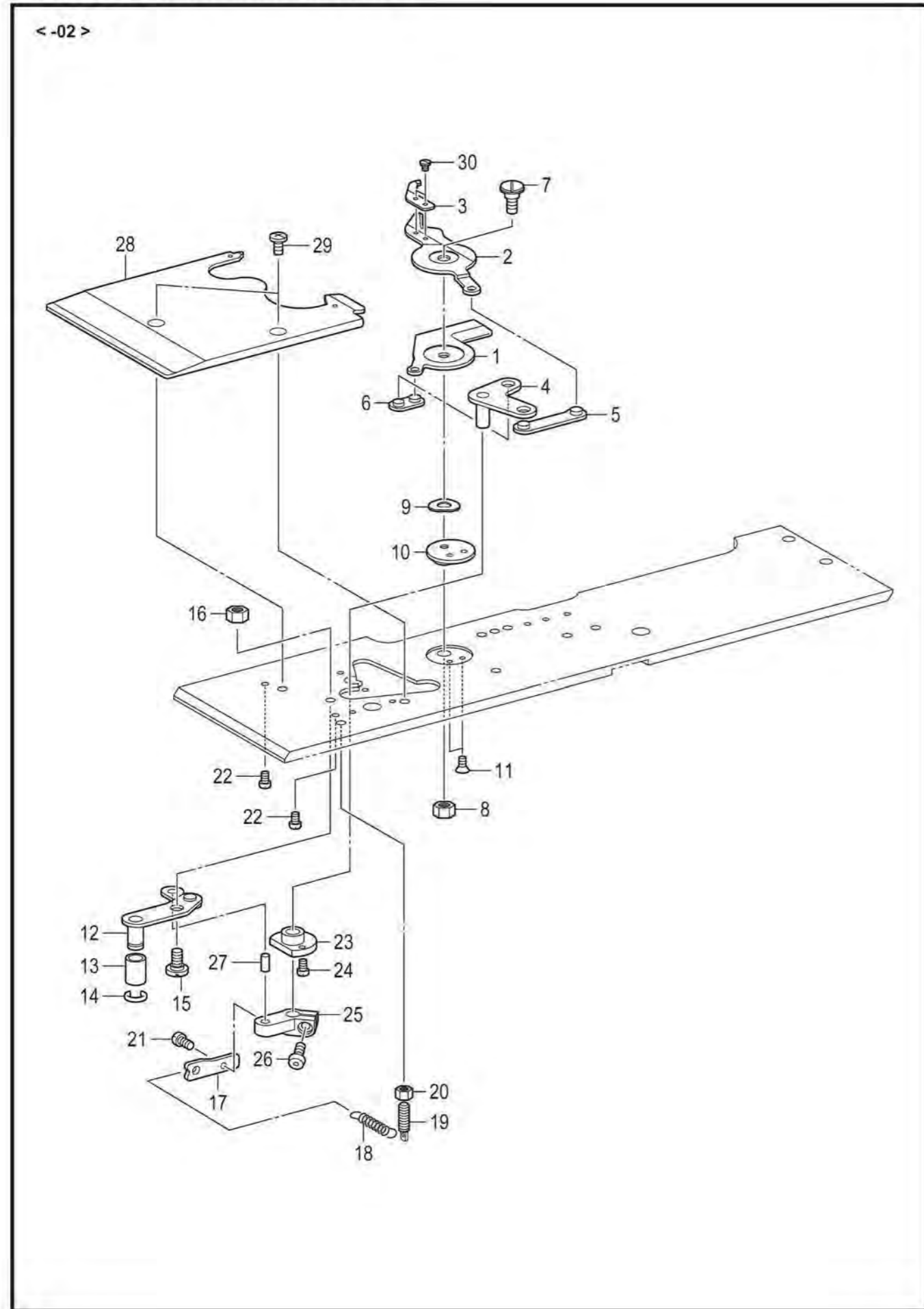

Q2. 切线装置 / Thread trimmer mechanism

参照号	零部件序号	数量	零部件名称	NAME OF PARTS	RM
			<用于-02>	<For -02>	
1	CSA6988001	1	动刀 R	MOVABLE KNIFE R	
2	CSA6989001	1	动刀 L	MOVABLE KNIFE L	
3	CSA6990101	1	挡线器	THREAD HANDLER	
4	CSA6991001	1	动刀驱动板	MOVABLE KNIFE DRIVING PLATE	
5	CSA6992001	1	切线连接组件 A	THREAD TRIMMER LINK A ASSY	
6	CSA6994001	1	切线连接组件 B	THREAD TRIMMER LINK B ASSY	
7	CS37660101	1	段螺钉 M4	SHOULDER SCREW, M4	
8	C021400202	1	六角螺母 M4	NUT 2 M4	
9	CS37654000	1	波纹垫圈	WAVE WASHER	
10	CS37655101	1	切刀支撑圈	KNIFE SUPPORT WASHER	
11	C141542001	2	螺钉 3.18	SCREW 3.18	
12	CSA6996001	1	切线连接杆组件 J	THREAD TRIMMER L-LEVER J ASSY	
13	CSA7778001	1	连接杆滚轮	LINK LEVER ROLLER	
14	C137191051	1	挡圈	STOP RING	
15	CSA5693001	1	段螺钉 M4	SHOULDER SCREW M4	
16	C021400306	1	六角螺母 M4	NUT 3 M4	
17	CSA6998101	1	弹簧挂钩	SPRING HOOK	
18	CSA6999101	1	切线弹簧	THREAD TRIMMER SPRING	
19	CS34902001	1	弹簧挂钩	SPRING HOOK	
20	C021350106	1	螺母 M3.5	NUT 1 M3.5	
21	C062260516	1	螺钉 M2.6X5	SCREW PAN M2.6X5	
22	C062300416	2	螺钉 M3X4	SCREW PAN M3X4	
23	CSA7001001	1	切线臂管套	BUSH TR TRIMMER ARM	
24	C062260516	2	螺钉 M2.6X5	SCREW PAN M2.6X5	
25	CSA7002101	1	切线杆臂 B	THREAD TRIMMER LEVER ARM B	
26	CS21716001	1	螺钉 M4X10	SCREW, BUTTON HEAD M4X10	
27	CS37858000	1	针销 4X8	NEEDLE PIN, 4X8	
28	CSA7003001	1	压板 JU	WORK CLAMP PLATE JU	
29	C060400516	2	螺钉 M4X5	SCREW BIND M4X5	
30	C153787001	2	螺钉 SM2.38	SCREW, SM2.38	



R. 面线剪切装置 / Upper thread trimmer mechanism

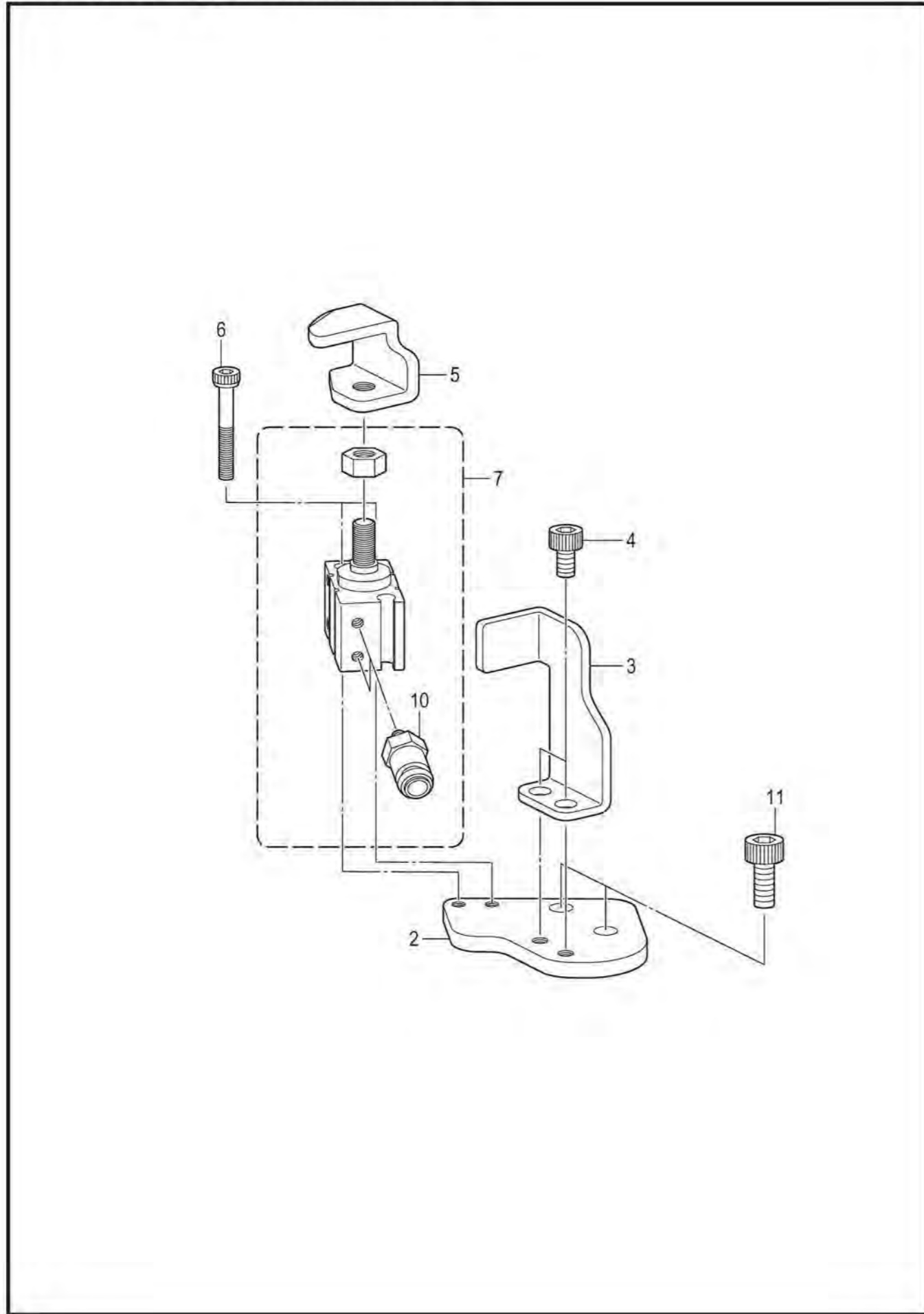

R. 面线剪切装置 / Upper thread trimmer mechanism

参照号	零部件序号	数量	零部件名称	NAME OF PARTS	RM
2	CSA7005001	1	气缸安装板	CYLINDER SETTING PLATE	
3	CSA7006001	1	气锤导向板	HAMMER GUIDE PLATE	
4	C018400636	2	螺栓 M4X6	BOLT SOCKET M4X6	
5	CSA7007001	1	气锤	HAMMER	
6	CS12053000	2	螺栓 M3X25 CQ2	BOLT, CQ2 M3X25	
7	CSA7008001	1	气缸组件	CYLINDER ASSY	
10	CSA7011001	2	接头 KJH04-M3	JOINT KJH04-M3	
11	C018501236	2	螺栓 M5X12	BOLT SOCKET M5X12	



S1. 控制箱装置 / Control box mechanism

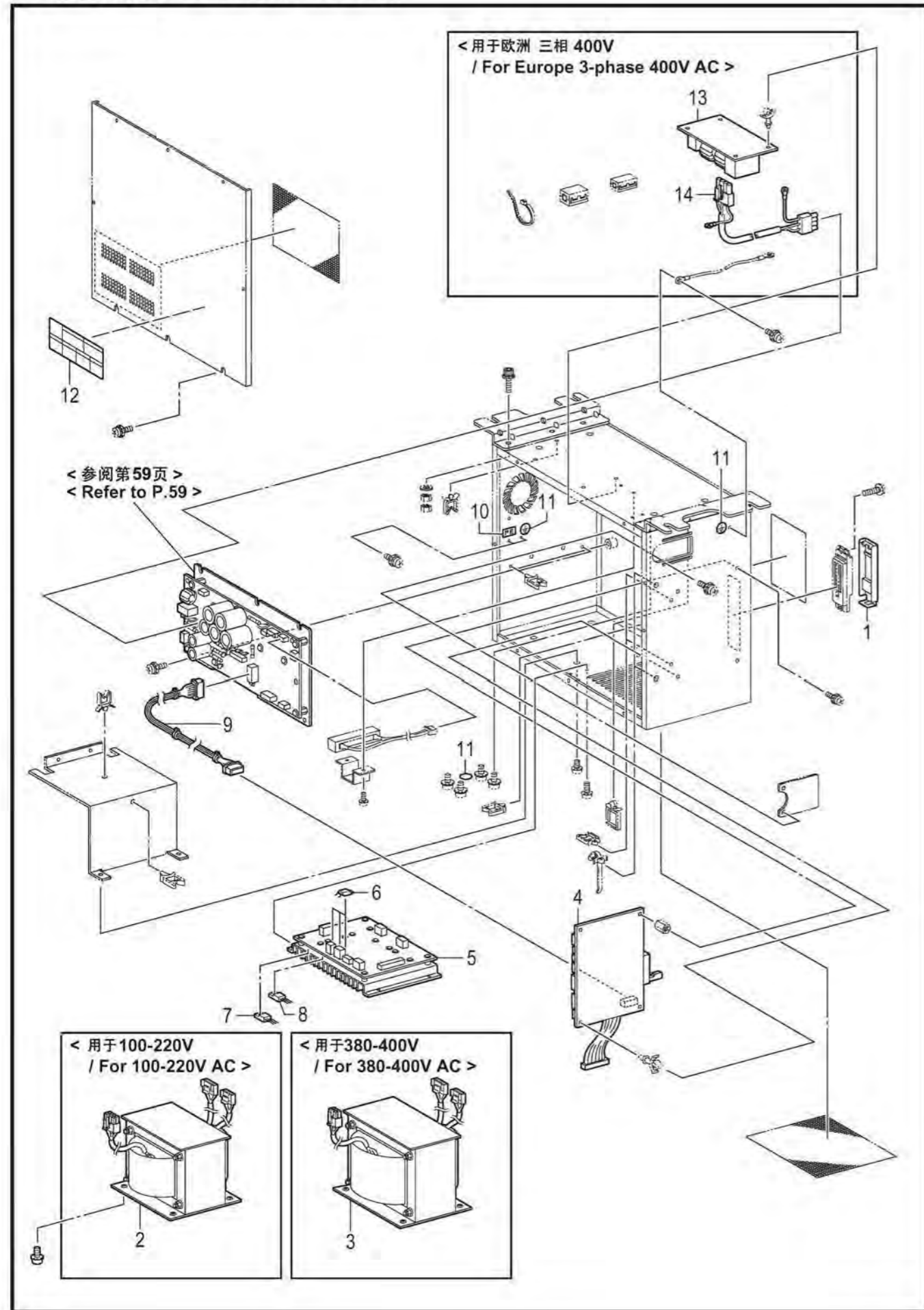

S1. 控制箱装置 / Control box mechanism

参照号	零部件序号	数量	零部件名称	NAME OF PARTS	RM
1	CSA6364001	1	盖组件 CF	CF CAP ASSY	
2	CSA3720101	1	变压器 LV <用于100-220V>	<For 100-220V AC> TRANSFORMER LOW VOLTAGE	
3	CSA3808101	1	变压器 HV <用于380-400V>	<For 380-400V AC> TRANSFORMER HIGH VOLTAGE	
4	CSA6554001	1	主基板组件 982	PCB ASSY MAIN 982	
5	CSA3739501	1	基板组件 PMD	PCB ASSY PMD	
6	CSA3744001	3	FET FS10ASJ-2	TRANSISTOR FET:FS10ASJ-2	
7	CSA3722001	1	MOSFET FX20KMJ2	TRANSISTOR FET:FX20KMJ-2	
8	CS49484000	1	MOSFETFS10KMJ-2	TRANSISTOR FET:FS10KMJ-2	
9	CSA3806001	1	电线	HARNESS MAIN POWER SUPPLY	
10	CS37059001	1	PE标记	LABEL, PE	
11	CS37060001	3	接地标记	LABEL, GROUNDING	
12	CJ04115001	1	感电标签(6国)	LABEL, ELEC. SHOCK 6 LANG.	
13	CSA3581101	1	基板组件 <用于欧洲 三相 400V>	<For Europe 3-phase 400V AC> PCB ASSY NF	
14	CSA3796001	1	电线 NF OUT	HARNESS NF OUT	



S2. 控制箱装置(电源马达基板) / Control box mechanism (Power supply motor PCB)

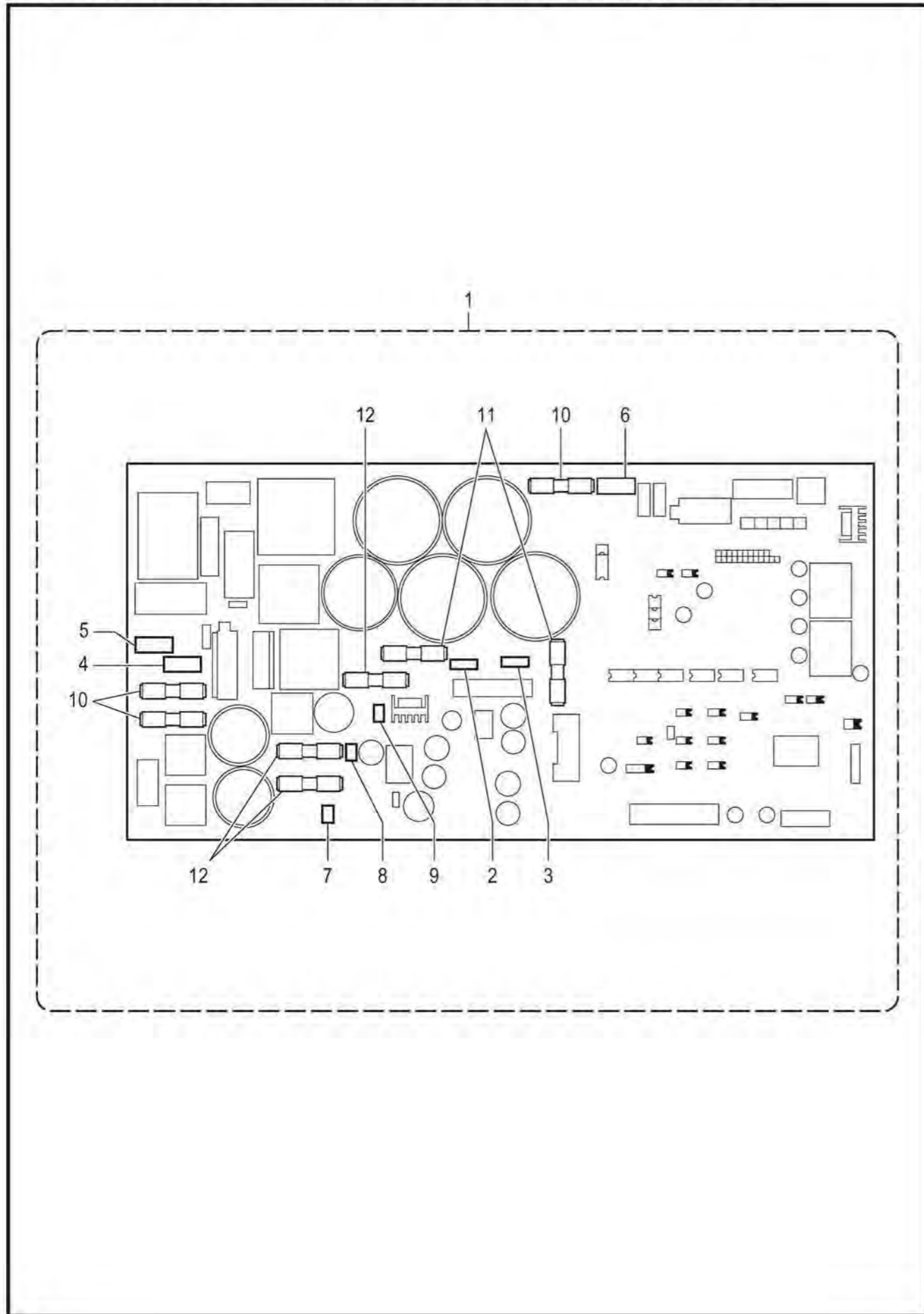

S2. 控制箱装置(电源马达基板) / Control box mechanism (Power supply motor PCB)

参照号	零部件序号	数量	零部件名称	NAME OF PARTS	RM
1	CSA3755201	1	电源马达基板组件	PCB ASSY POWER SUPPLY MOTOR	
2	CSA3765001	1	电阻 V10D101	VARISTOR:V10D101	
3	CSA3766001	1	电阻 V10D241	VARISTOR:V10D241	
4	CSA3767001	1	电阻 V14D511	VARISTOR:V14D511	
5	CSA3768001	1	电阻 V14D561	VARISTOR:V14D561	
6	CSA3762001	1	电阻 V14D911	VARISTOR:V14D911	
7	CSA3769001	1	电阻 V5D121	VARISTOR:V5D121	
8	CSA3770001	1	电阻 V5D330	VARISTOR:V5D330	
9	CSA3771001	1	电阻 V5D820	VARISTOR:V5D820	
10	CSA3794001	3	保险丝 250V-15A	G FUSE S 15A	
11	CSA3795001	2	保险丝 250V-6A	G FUSE S 6A	
12	CSA7794001	3	保险丝 3A	G FUSE S 3A	



T. 开关装置 / Power switch mechanism

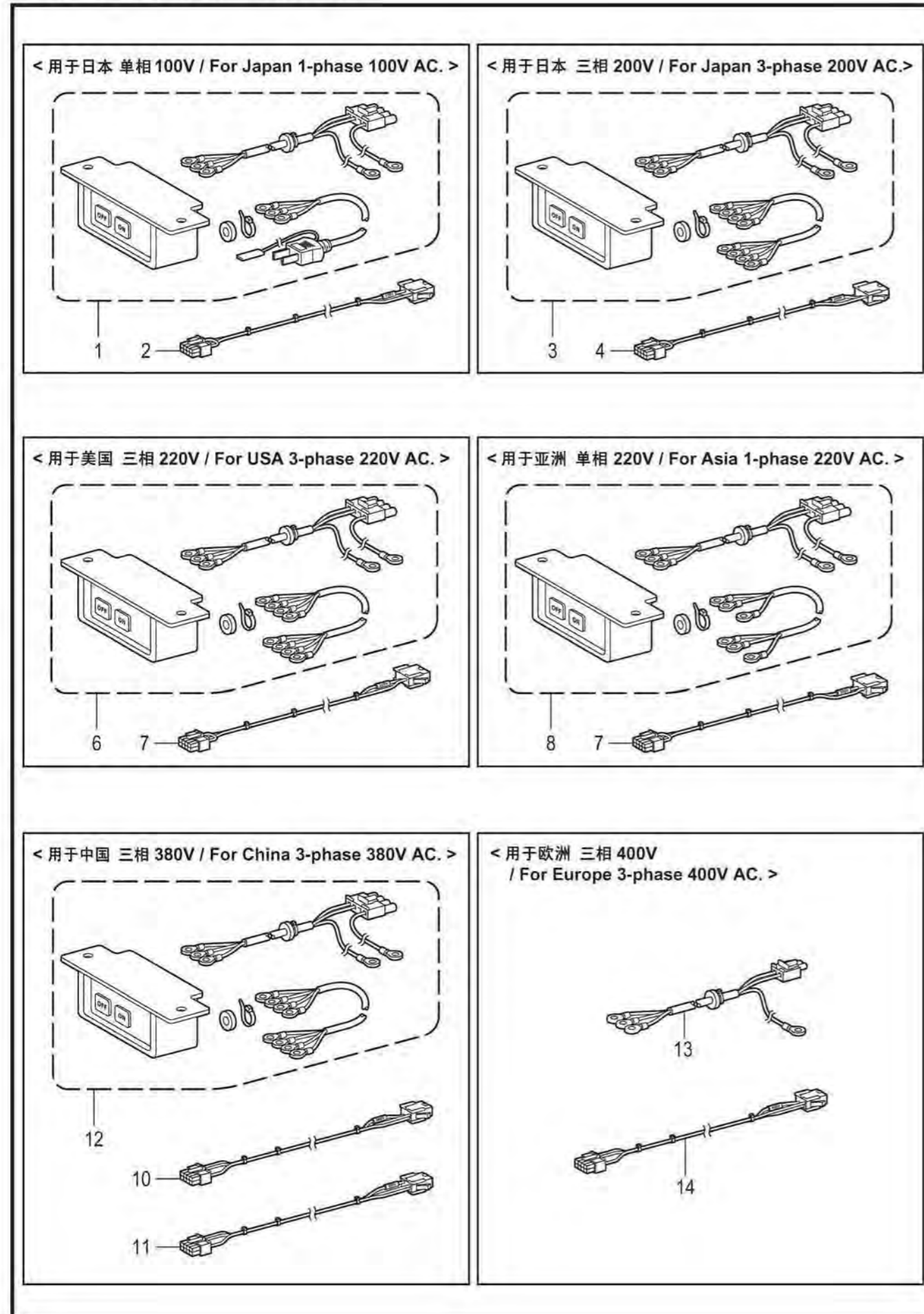

T. 开关装置 / Power switch mechanism

参照号	零部件序号	数量	零部件名称	NAME OF PARTS	RM
1	CSA3813001	1	<用于日本 单相 100V> 电源开关组件 1P-JP	<For Japan 1-phase 100V AC.> POWER SUPPLY SWITCH ASSY,1P-JP	
2	CSA3822001	1	V切换电线 100V	VOLTAGE SELECT HARNESS 100V	
3	CSA3819001	1	<用于日本 三相 200V> 电源开关组件 3P-JP	<For Japan 3-phase 200V AC.> POWER SUPPLY SWITCH ASSY,3P-JP	
4	CSA3825001	1	V切换电线 200V	VOLTAGE SELECT HARNESS 200V	
6	CSA3816001	1	<用于美国 三相 220V> 电源开关组件 3P-L	<For USA 3-phase 220V AC.> POWER SUPPLY SWITCH ASSY,3P-L	
7	CSA3812001	1	V切换电线 220V	VOLTAGE SELECT HARNESS 220V	
8	CSA3809001	1	<用于亚洲 单相 220V> 电源开关组件 1P	<For Asia 1-phase 220V AC.> POWER SUPPLY SWITCH ASSY,1P	
7	CSA3812001	1	V切换电线 220V	VOLTAGE SELECT HARNESS 220V	
10	CSA3827001	1	<用于中国 三相 380V> V切换电线 380V	<For China 3-phase 380V AC.> VOLTAGE SELECT HARNESS 380V	
11	CSA3789101	1	V切换电线 H220V	VOLTAGE SELECT HARNESS H220V	
12	CSA4510001	1	电源开关组件 3P-H	POWER SUPPLY SWITCH ASSY,3P-H	
13	CSA3838001	1	<用于欧洲 三相 400V> 电线组件 AC IN EC	<For Europe 3-phase 400V AC.> HARNESS ASSY, AC IN EC	
14	CSA3828001	1	V切换电线 400V	VOLTAGE SELECT HARNESS 400V	



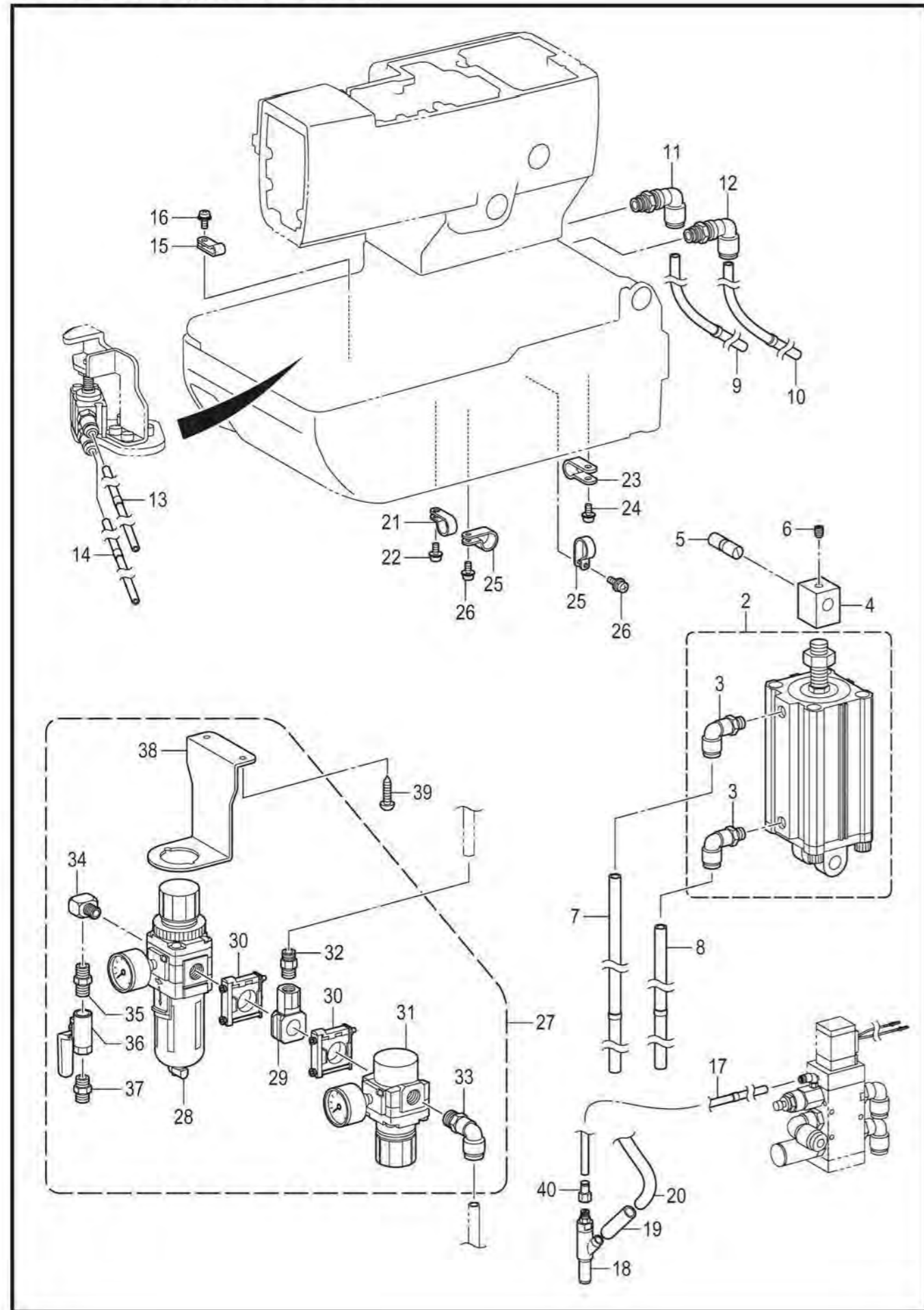

参照号	零部件序号	数量	零部件名称	NAME OF PARTS	RM
2	CS35360000	1	气缸组件 63X100	CYLINDER ASSY, 63X100	
3	CS35426100	2	弯管 10-4	ELBOW 10-4	
4	CSA7016001	1	气缸连接	CYLINDER ROD	
5	CSA7017001	1	气缸连接轴	CYLINDER ROD SHAFT	
6	C014060836	1	固定螺钉 M6X8	SET SCREW SOCKET (CP) M6X8	
7	CSA7018001	1	空气管 10X6.5-6A	AIR TUBE 10X6.5-6A	
8	CSA7019001	1	空气管 10X6.5-5A	AIR TUBE 10X6.5-5A	
9	CSA7020001	1	空气管 10X6.5-5	AIR TUBE 10X6.5-5	
10	CSA7021001	1	空气管 10X6.5-6	AIR TUBE 10X6.5-6	
11	CSA7022001	1	弯管 KQ2LE10-5	UNION KQ2LE10-5	
12	CSA8040001	1	弯管 KQ2LE10-6	UNION KQ2LE10-6	
13	CSA7023001	1	空气管 4X2.5-13	AIR TUBE 4X2.5-13	
14	CSA7159001	1	空气管 4X2.5-14	AIR TUBE 4X2.5-14	
15	CS00480000	1	电线夹 #5	CORD HOLDER, 5N	
16	C0A4400806	1	螺栓(带垫圈) M4X8DA	SCREW PAN (S/P WASHER) M4X8	
17	CSA7024001	1	空气管 4X2.5-2	AIR TUBE 4X2.5-2	
18	CS34569000	1	文吐里管	VENTURI TUBE	
19	CSA7027001	1	空气管 16X12-80	AIR TUBE 16X12-80	
20	CSA7028001	1	布屑管	KNIFE TRASH TUBE	
21	C525567000	1	电线夹 #8	CORD HOLDER #8	
22	C0A4400806	1	螺栓(带垫圈) M4X8DA	SCREW PAN (S/P WASHER) M4X8	
23	C552908000	1	电线夹 #14	CORD HOLDER #14	
24	C0A4401206	1	螺栓(带垫圈) M4X12DA	SCREW PAN (S/P WASHER) M4X12	
25	C554482000	2	电线夹 #12	CORD HOLDER #12	
26	C0A4401206	2	螺栓(带垫圈) M4X12DA	SCREW PAN (S/P WASHER) M4X12	
27	CSA8119001	1	压缩空气大组件	AIR UNIT SET	
28	CSA7583001	1	FR复合件 AW30	FR UNIT AW30	
29	CSA7584001	1	T隔板	T SPACER	
30	CSA7585001	2	隔板	SPACER	
31	CSA7586001	1	R复合件 AR30	R UNIT AR30	
32	CS59219000	1	管接头 08-PT1/4	HALF UNION, 08-PT1/4	
33	CSA7587001	1	弯管 KQ2L10-02S	ELBOW KQ2L10-02S	
34	CSA7588001	1	接管 PT 1/4	ELBOW PT 1/4	
35	CSA7589001	1	中间管接头 1/4	MIDDLE NIPPLE 1/4	
36	CSA6573001	1	球阀 V03 1/4	BALL VALVE V03 1/4	
37	CSA7595001	1	中间管接头 1/4	MIDDLE NIPPLE 1/4	
38	CSA7580001	1	安装板	SETTING PLATE	
39	C031553202	2	木螺钉 M5.5X32	WOOD SCREW ROUND M5.5X32	
40	CSA8003001	1	空气接头	AIR CONNECTOR	



U2. 空压装置 / Air pressure mechanism

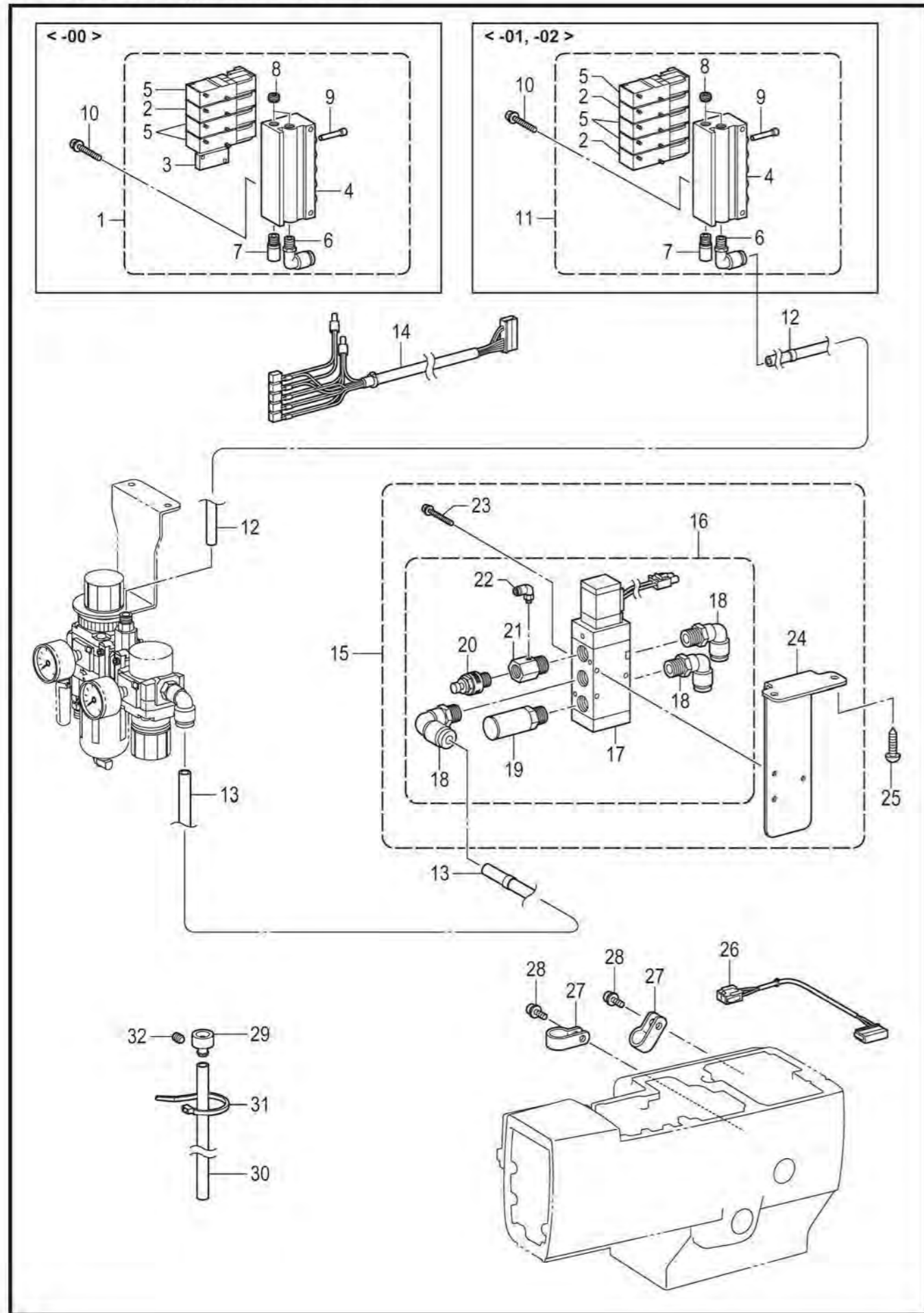

U2. 空压装置 / Air pressure mechanism

参照号	零部件序号	数量	零部件名称	NAME OF PARTS	RM
			<用于-00>	<For -00>	
1	CSA7085001	1	电磁阀组件 4	SOLENOID VALVE 4 ASSY	
2	CS39116100	1	阀 VQZ2151S-5	VALVE VQZ2151S-5	
3	CS53982000	1	遮隔板组件	BLANKING PLATE ASSY	
4	CSA7032001	1	复式接头 5	MANIFOLD 5	
5	CS39115100	3	阀门 VQZ2151-5	VALVE, VQZ2151-5	
6	CS14159000	1	弯管 1/8-8	ELBOW 1/8-8	
7	CSA5283001	1	消音器 AN103-1	SILENCER AN103-1	
8	C153274001	2	盖 1/8	CAP, 1/8	
9	CSA7033001	1	插销 4	PLUG 4	
10	C0A4403506	2	螺栓(带垫圈) M4X35DA	SCREW PAN (S/P WASHER) M4X35	
			<用于-01和-02>	<For -01 & -02>	
11	CSA7031001	1	电磁阀组件 5	SOLENOID VALVE 5 ASSY	
2	CS39116100	2	阀 VQZ2151S-5	VALVE VQZ2151S-5	
4	CSA7032001	1	复式接头 5	MANIFOLD 5	
5	CS39115100	3	阀门 VQZ2151-5	VALVE, VQZ2151-5	
6	CS14159000	1	弯管 1/8-8	ELBOW 1/8-8	
7	CSA5283001	1	消音器 AN103-1	SILENCER AN103-1	
8	C153274001	2	盖 1/8	CAP, 1/8	
9	CSA7033001	1	插销 4	PLUG 4	
10	C0A4403506	2	螺栓(带垫圈) M4X35DA	SCREW PAN (S/P WASHER) M4X35	
12	CSA7034001	1	空气管 8X5-1	AIR TUBE 8X5-1	
13	CSA7035001	1	空气管 10X6.5-4	AIR TUBE 10X6.5-4	
14	CSA6525001	1	阀接线组 X5	VALVE HARNESS ASSY X5	
15	CSA8120101	1	切刀阀大组件	CUTTER VALVE SET	
16	CSA7591101	1	阀组件	VALVE ASSY	
17	CSA7592101	1	阀门 VF5120-5G-03	VALVE VF5120-5G-03	
18	CSA7593001	3	弯管	ELBOW KQ2L10-03S	
19	CSA7594001	1	消音器 AN303-03	SILENCER AN303-03	
20	CSA7598001	1	消音器 ASN2-02	SILENCER ASN2-02	
21	CSA7596001	1	接头 3/8X1/4-M5	JOINT 3/8X1/4-M5	
22	CSA7597001	1	弯管	ELBOW KJL04-M5	
23	C0A4404006	3	螺栓(带垫圈) M4X40DA	SCREW PAN (S/P WASHER) M4X40	
24	CSA7581001	1	阀安装板	VALVE SETTING PLATE	
25	C031553202	2	木螺钉 M5.5X32	WOOD SCREW ROUND M5.5X32	
26	CSA6526101	1	气锤阀接线	HAMMER VALVE HARNESS	
27	CS00470000	2	电线夹 #16	CORD HOLDER, 16N	
28	C0A5401006	2	螺栓(带垫圈) M4X10DB	SCREW PAN (S/P WASHER) M4X10	
29	CSA7046001	1	管接头	HOSE JOINT	
30	CSA7047001	1	油管	OIL TUBE	
31	C228475000	1	电线夹 1.9X80	FASTENING BAND 1.9X80	
32	C012500536	1	螺钉 M5X5	SET SCREW SOCKET (FT) M5X5	



V. 电气部品装置 / Power supply equipment mechanism

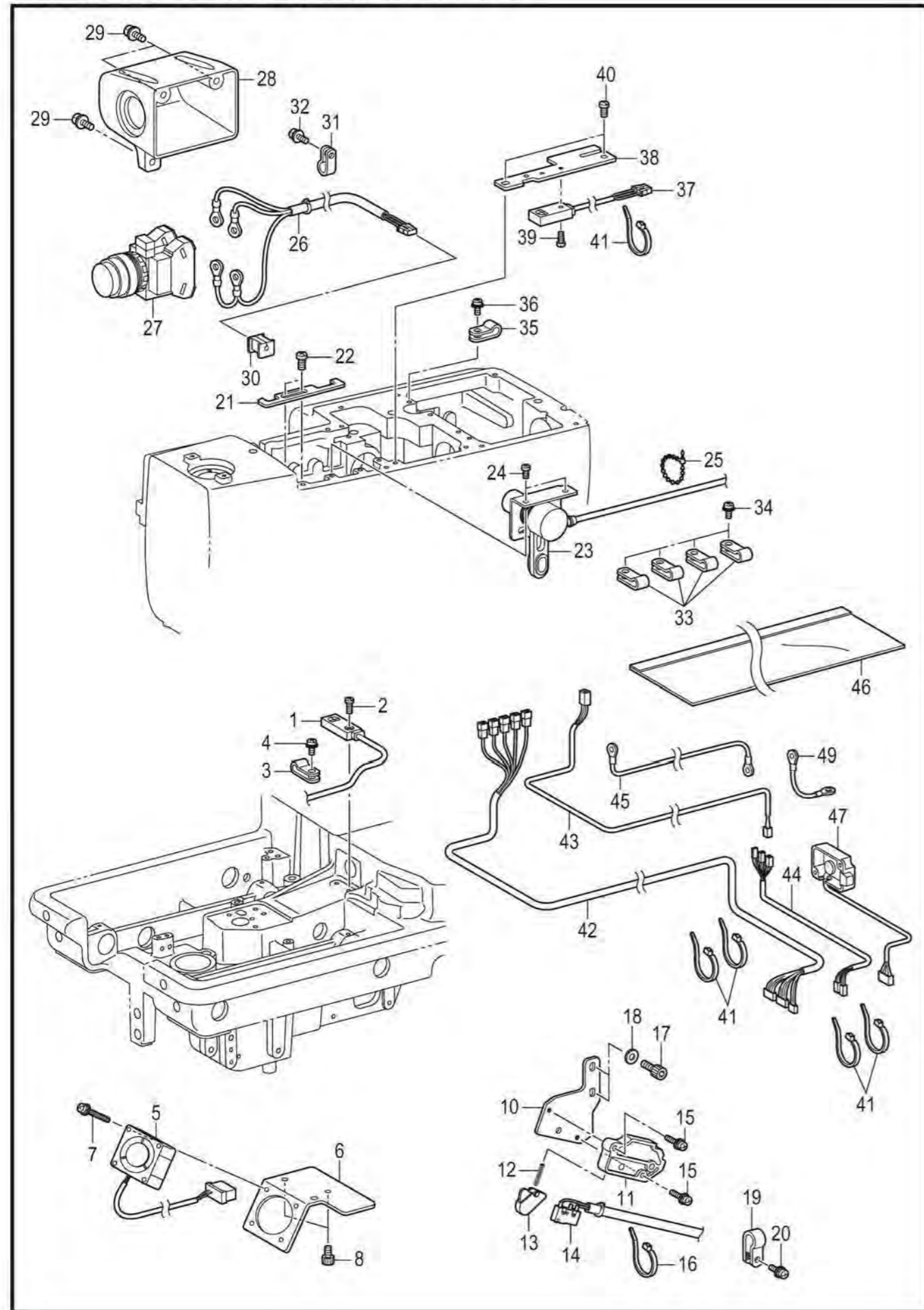

V. 电气部品装置 / Power supply equipment mechanism

参照号	零部件序号	数量	零部件名称	NAME OF PARTS	RM
1	CSA6530001	1	Y原点感应器	Y-POSITION SENSOR	
2	C062300816	1	螺钉 M3X8	SCREW PAN M3X8	
3	CS10243000	1	尼龙夹 NK-3N	CORD HOLDER, NK-3N	
4	C0A4400806	1	螺栓(带垫圈) M4X8DA	SCREW PAN (S/P WASHER) M4X8	
5	CSA6618001	1	DC风扇马达组件 40	DC FAN MOTOR ASSY 40	
6	CSA5696001	1	风扇支架	FAN HOLDER	
7	C0A5302005	4	螺栓(带垫圈) M3X20DB	SCREW PAN (S/P WASHER) M3X20	
8	C018400836	2	螺栓 M4X8	BOLT SOCKET M4X8	
10	CSA5729001	1	安全开关板	SAFETY SWITCH PLATE	
11	CSA5730001	1	安全开关基座	SAFETY SWITCH BASE	
12	CSA5731001	1	开关弹簧	SAFETY SWITCH SPRING	
13	CSA5732001	1	开关手柄	SAFETY SWITCH LEVER	
14	CSA6533001	1	头部开关组件	SWITCH ASSY MACHINE HEAD	
15	CSA7293001	2	螺栓(带垫圈) M3X12	SCREW, PAN (S/P W) M3X12	
16	CS04159000	1	线夹 1M	BAND, 1M	
17	C018400836	2	螺栓 M4X8	BOLT SOCKET M4X8	
18	C025040236	2	平垫圈 M4	WASHER PLAIN M 4	
19	C525664000	1	电线夹 #6	CORD HOLDER #6	
20	C0A4400806	1	螺栓(带垫圈) M4X8DA	SCREW PAN (S/P WASHER) M4X8	
21	CSA5733001	1	电线压板	CORD HOLDER	
22	C062400816	2	螺钉 M4X8	SCREW PAN M4X8	
23	CSA5734101	1	切刀感应器组件	CUTTER SENSOR ASSY	
24	C062400816	2	螺钉 M4X8	SCREW PAN M4X8	
25	C340400001	1	线夹	BEAD BAND	
26	CSA6531101	1	停止开关接线	STOP SWITCH HARNESS	
27	CSA7488001	1	开关 HW1B-M211B	SWITCH HW1B-M211B	
28	CSA5737001	1	开关罩	SWITCH COVER	
29	C0A4400806	3	螺栓(带垫圈) M4X8DA	SCREW PAN (S/P WASHER) M4X8	
30	CSA5738001	1	电线套	CORD BUSH	
31	C625010000	1	尼龙夹 NK-2N	NYLON CLAMP NK-2N	
32	C0A4400806	1	螺栓(带垫圈) M4X8DA	SCREW PAN (S/P WASHER) M4X8	
33	C149547000	4	压线板	CORD HOLDER, 4N	
34	C0A4400806	4	螺栓(带垫圈) M4X8DA	SCREW PAN (S/P WASHER) M4X8	
35	CS10243000	1	尼龙夹 NK-3N	CORD HOLDER, NK-3N	
36	C0A4400806	1	螺栓(带垫圈) M4X8DA	SCREW PAN (S/P WASHER) M4X8	
37	CSA5740001	1	针摆感应器组件	ZIGZAG SENSOR ASSY	
38	CSA5741001	1	感应器安装板	SENSOR SETTING PLATE	
39	C062300816	1	螺钉 M3X8	SCREW PAN M3X8	
40	C062400816	2	螺钉 M4X8	SCREW PAN M4X8	
41	C228475000	5	电线夹 1.9X80	FASTENING BAND 1.9X80	
42	CSA6532001	1	电线组件	CONNECT HARNESS ASSY	
43	CSA6535001	1	面线电磁铁电线	UP SOLENOID HARNESS	
44	CSA6536001	1	电磁铁电线	SOLENOID HARNESS	
45	CSA5434001	1	接地线 700	GROUND WIRE 700	
46	CSA6636001	1	粘链管 40X800	QUICK TUBE ASSY 40X800	
47	CSA7119001	1	头部检出复合件	HEAD DETECTION UNIT ASSY	
49	CSA5433001	1	接地线 40	GROUND WIRE 40	



W. 操作盘装置 / Operation panel mechanism

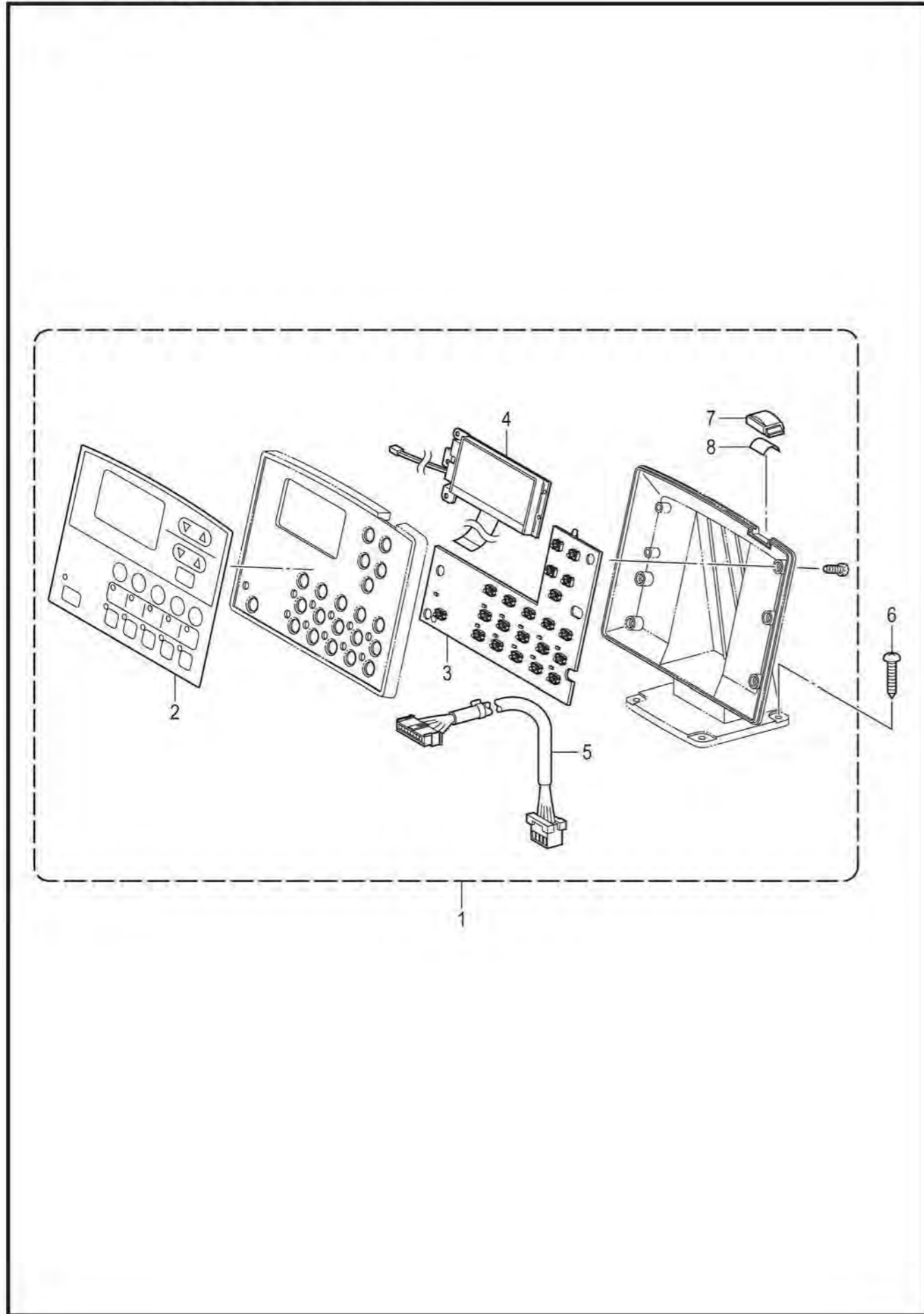

W. 操作盘装置 / Operation panel mechanism

参照号	零部件序号	数量	零部件名称	NAME OF PARTS	RM
1	CSA6547001	1	操作盘组件	OPERATION PANEL ASSY	
2	CSA6550001	1	操作盘面板	PANEL SHEET	
3	CSA5148001	1	操作盘基板组件	PCB ASSY PANEL	
4	CSA5360001	1	灯光板组件	LIGHT PLATE ASSY	
5	CSA6546001	1	操作盘接线	PANEL HARNESS	
6	C0B0452006	4	圆头木螺钉 M4.5X20	WOOD SCREW ROUND M4.5X20	
7	CJ03974001	1	护灯罩	LAMP HOLDER	
8	CJ04146001	1	薄膜 75PBA	DIFFUSION SHEET 75PBA	



X. 马达装置 / Motor mechanism

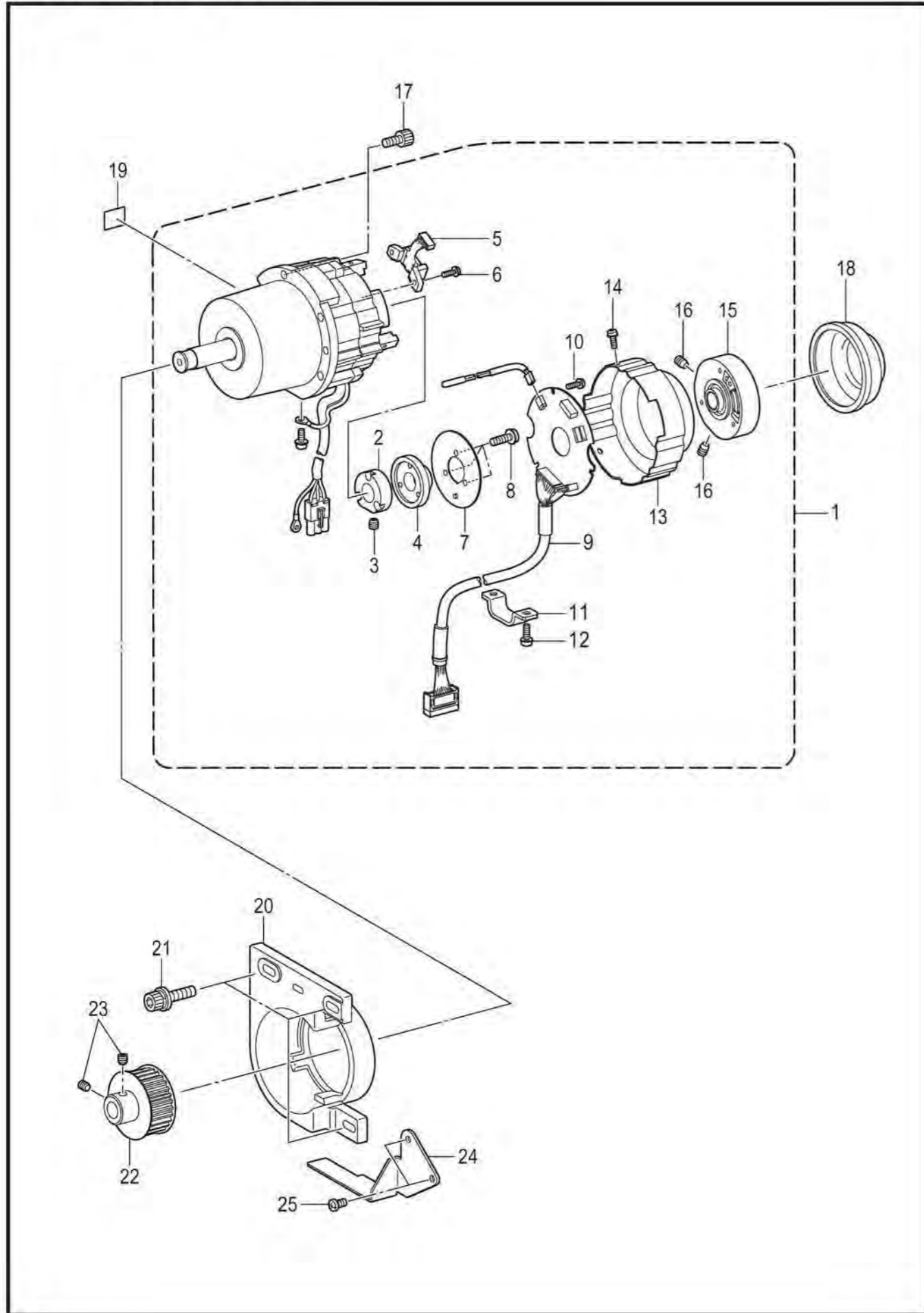

X. 马达装置 / Motor mechanism

参照号	零部件序号	数量	零部件名称	NAME OF PARTS	RM
1	CSA7476001	1	马达组件 CDD	MOTOR ASSY CDD HATOME	
2	CJ03955001	1	磁鼓 CDD	DRUM CDD	
3	C014400632	2	螺钉 M4X6	SET SCREW SOCKET (CP) M4X6	
4	CJ03956001	1	磁铁 180P36	MAGNET 180P36	
5	CJ03957001	1	MR感应器组件 180P	MR SENSOR ASSY 180P	
6	C0A4300806	2	螺栓(带垫圈) M3X8DA	SCREW PAN (S/P WASHER) M3X8	
7	CJ03958001	1	屏蔽板 CDD	SHIELD PLATE CDD	
8	C0A4261006	3	螺栓(带垫圈) M2.6X10DA	SCREW PAN (S/P WASHER) M2.6X10	
9	CSA7480001	1	基板组件 ENC	ENC PCB ASSY HATOME	
10	C0A5300606	3	螺栓(带垫圈) M3X6DB	SCREW PAN (S/P WASHER) M3X6	
11	CJ04230001	1	电线固定夹 CDD-HT	CORD HOLDER CDD-HT	
12	C0A4401006	3	螺栓(带垫圈) M4X10DA	SCREW PAN (S/P WASHER) M4X10	
13	CJ04388001	1	编码器盖 430D	ENCORDER COVER 430D	
14	C0A4300806	3	螺栓(带垫圈) M3X8DA	SCREW PAN (S/P WASHER) M3X8	
15	CJ04303001	1	同步轮组件 430D	PULLEY HOLDER ASSY 430D	
16	C014500632	2	螺钉 M5X6	SET SCREW SOCKET (CP) M5X6	
17	C018501636	5	螺栓 M5X16	BOLT SOCKET M5X16	
18	CSA7012001	1	马达罩	MOTOR COVER	
19	CJ03663001	1	高温标签 13X20	LABEL, HIGH TEMP. 13X20	
20	CSA7013001	1	马达支架	MOTOR HOLDRER	
21	CS58636001	3	螺栓(带垫圈) M8X30	BOLT SOCKET (S/P WASHER)M8X30	
22	CSA5549001	1	同步手轮组件	TIMING PULLEY ASSY	
23	CS23651001	2	固定螺钉 M6X6	SET SCREW SOCKET (FT) M6X6	
24	CSA7014001	1	皮带导向	BELT GUIDE	
25	C062400816	2	螺钉 M4X8	SCREW PAN M4X8	



Y. 踏板开关关系 / Foot switch pedal mechanism

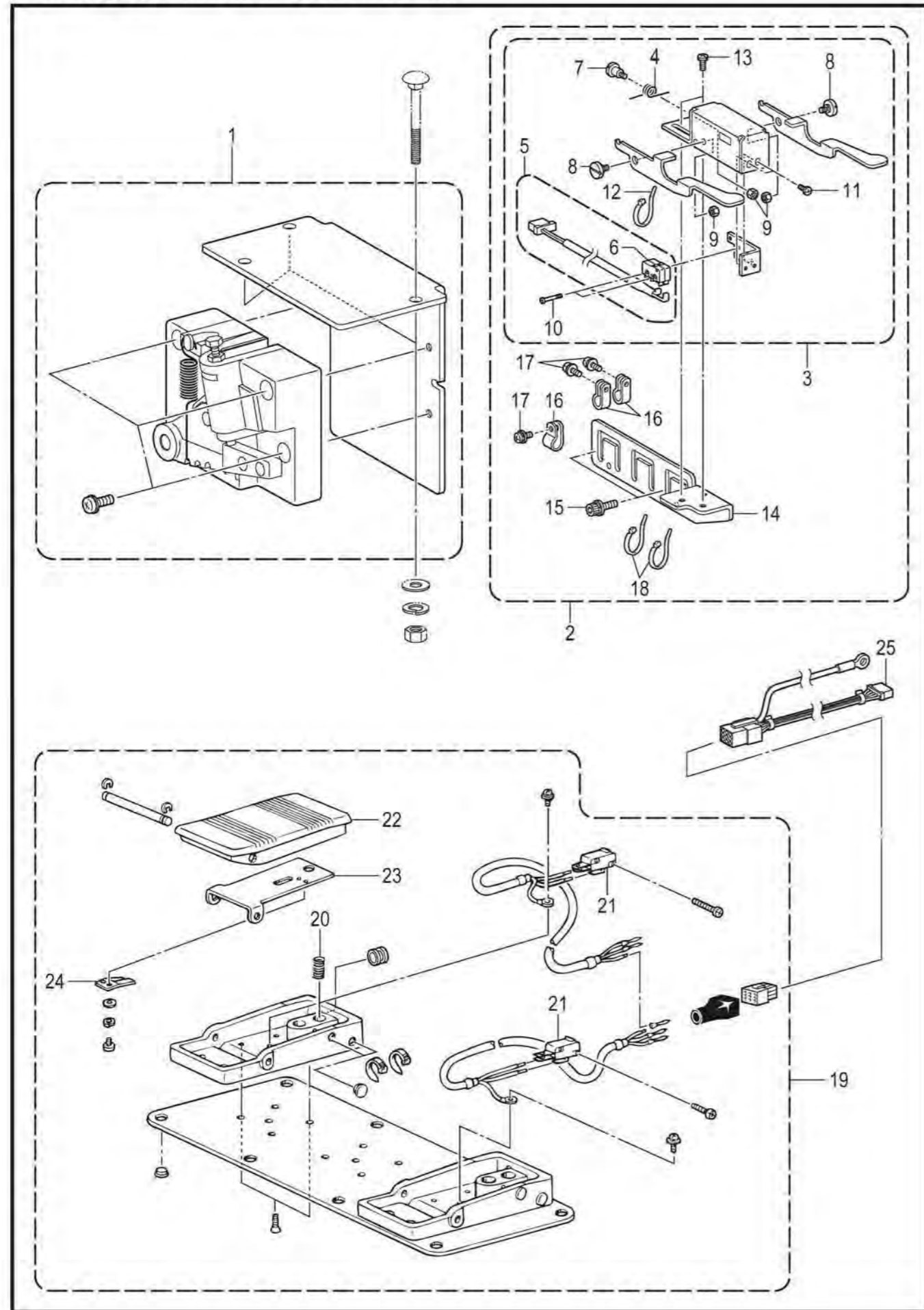

Y. 踏板开关关系 / Foot switch pedal mechanism

参照号	零部件序号	数量	零部件名称	NAME OF PARTS	RM
1	CSA6567101	1	<用于脚踏板> 踏板复合件 B	<For treadle> TREADLE UNIT B ASSY	
2	CSA7121001	1	<用于手动开关> 手动开关大组件	<For hand start switch> HAND START SWITCH UNIT	
3	CSA7122001	1	手动开关组件	HAND START SWITCH ASSY	
4	CS39914001	1	开关弹簧	SWITCH LEVER SPRING	
5	CSA7123001	1	手动开关	HAND START SWITCH	
6	CS02699001	2	微调开关	MICRO SWITCH	
7	CS34922101	1	段螺钉 M4	SHOULDER SCREW M4	
8	CS34966001	2	段螺钉 M4	SHOULDER SCREW M4	
9	C021400202	3	六角螺母 M4	NUT 2 M4	
10	C146124001	2	螺钉 SM2.38	SCREW, SM2.38	
11	C060300616	2	螺钉 M3X6	SCREW BIND M3X6	
12	CS04557000	1	电线夹 PLT1M	BAND, PLT1M	
13	C060400816	2	螺钉 M4X8	SCREW BIND M4X8	
14	CSA7124001	1	手动开关安装板	HAND SWITCH SETTING PLATE	
15	CS55485001	2	螺栓(带垫圈) M5X12	BOLT SOCKET (S/P WASHER)M5X12	
16	CS10243000	3	尼龙夹 NK-3N	CORD HOLDER, NK-3N	
17	C0A4400806	3	螺栓(带垫圈) M4X8DA	SCREW PAN (S/P WASHER) M4X8	
18	C228475000	2	电线夹 1.9X80	FASTENING BAND 1.9X80	
19	CS42838301	1	<用于2连脚踏板> 2连脚踏板开关 2SW	<For 2-pedal foot switch> 2-PEDAL FOOT SWITCH 2	
20	CS38170001	2	弹簧	FOOT PEDAL SPRING	
21	CS36260000	2	开关 VX	PIN BUTTON MICRO SWITCH, VX	
22	CS38174000	2	脚踏板	FOOT PEDAL	
23	CS38175101	2	脚踏护板	PROTECTION PLATE PEDAL	
24	CS38176101	2	弹簧板	SPRING, PLATE	
25	CSA3784001	1	脚开关变换配线	CONVERSION HARNESS FOOT SW	



AA1. 附属装置 / Attachment set

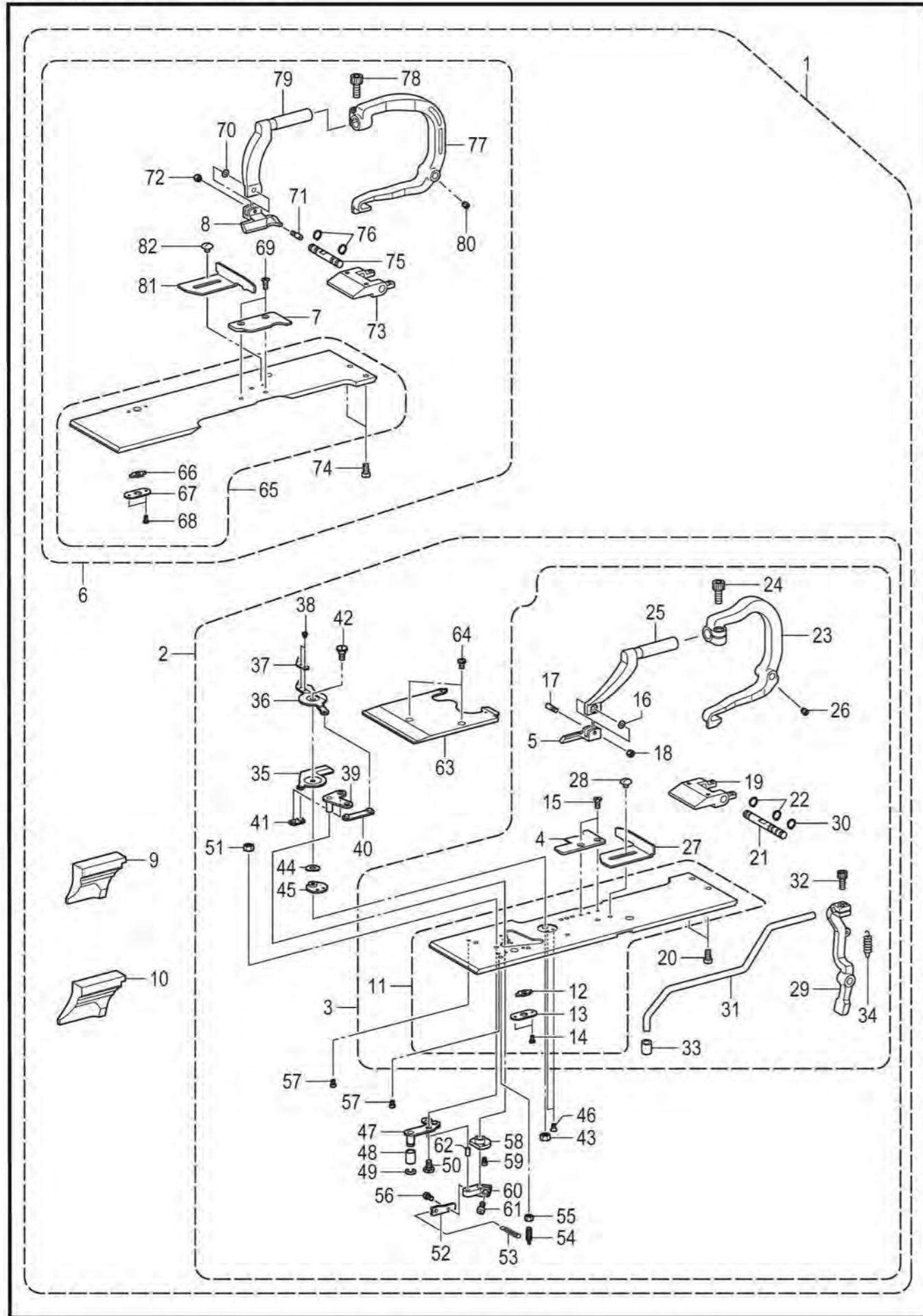

AA1. 附属装置 / Attachment set

参照号	零部件序号	数量	零部件名称	NAME OF PARTS	RM
			<规格变换用零部件>	<For exchange parts>	
			<用于-02: L1422>	<For -02: L1422>	
1	CSA7750001	1	规格变换零部件组 (L1422)	EXCHANGE PARTS SET L1422	
2	CSA7748001	1	L1422-板R组件	L1422-PLATE R ASSY	
3	CSA7728001	1	压脚板组件 R1422	WORK CLAMP PLATE R1422 ASSY	
4	CSA7102001	1	针板 L1422R	NEEDLE PLATE L1422R	
5	CSA7092001	1	布压板 R-JL1422	WORK CLAMP R-JL1422	
6	CSA7749001	1	压脚板组件 L1422	WORK CLAMP PLATE L1422 ASSY	
7	CSA7097001	1	针板 L1422L	NEEDLE PLATE L1422L	
8	CSA7087001	1	布压板 L-JL1422	WORK CLAMP L-JL1422	
9	CS37704001	1	气锤 S16	HAMMER, S16	
10	CS37706001	1	气锤 S20	HAMMER, S20	
			<用于-02: L2230>	<For -02: L2230>	
1	CSA7752001	1	规格变换零部件组 (L2230)	EXCHANGE PARTS SET L2230	
2	CSA7751001	1	L2230-板R组件	L2230-PLATE R ASSY	
3	CSA6728001	1	压脚板组件 R2230	WORK CLAMP PLATE R2230 UNIT	
4	CSA6731001	1	针板 L2230R	NEEDLE PLATE L 2230R	
5	CSA6732001	1	压布 R-JL2230	WORK CLAMP R-JL2230	
6	CSA6738001	1	压脚板组件 L2230	WORK CLAMP PLATE L2230 UNIT	
7	CSA6741001	1	针板 L2230L	NEEDLE PLATE L 2230L	
8	CSA6742001	1	布压板 L-JL2230	WORK CLAMP L-JL2230	
9	CS37708001	1	气锤 S24	HAMMER, S24	
10	CS42053001	1	气锤 S28	HAMMER, S28	
			<用于-02: L2634>	<For -02: L2634>	
1	CSA7756001	1	规格变换零部件组 (L2634)	EXCHANGE PARTS SET L2634	
2	CSA7754001	1	L2634-板R组件	L2634-PLATE R ASSY	
3	CSA7753001	1	压脚板组件 R2634	WORK CLAMP PLATE R2634 ASSY	
4	CSA7103001	1	针板 L2634R	NEEDLE PLATE L2634R	
5	CSA7093001	1	布压板 R-JL2634	WORK CLAMP R-JL2634	
6	CSA7755001	1	压脚板组件 L2634	WORK CLAMP PLATE L2634 ASSY	
7	CSA7098001	1	针板 L2634L	NEEDLE PLATE L2634L	
8	CSA7088001	1	布压板 L-JL2634	WORK CLAMP L-JL2634	
9	CS37198001	1	气锤 28	HAMMER, 28	
10	CS37200001	1	气锤 32	HAMMER, 32	
			<用于-02: L3442>	<For -02: L3442>	
1	CSA7764001	1	规格变换零部件组 (L3442)	EXCHANGE PARTS SET L3442	
2	CSA7758001	1	L3442-板R组件	L3442-PLATE R ASSY	
3	CSA7757001	1	压脚板组件 R3442	WORK CLAMP PLATE R3442 ASSY	
4	CSA7104001	1	针板 L3442R	NEEDLE PLATE L3442R	
5	CSA7094001	1	布压板 R-JL3442	WORK CLAMP R-JL3442	
6	CSA7762001	1	压脚板组件 L3442	WORK CLAMP PLATE L3442 ASSY	
7	CSA7099001	1	针板 L3442L	NEEDLE PLATE L3442L	
8	CSA7089001	1	布压板 L-JL3442	WORK CLAMP L-JL3442	
9	CS37202001	1	气锤 36	HAMMER, 36	
10	CSA7106001	1	气锤 42	HAMMER 42	
			<用于-02: L1826>	<For -02: L1826>	
1	CSA7771001	1	规格变换零部件组 (L1826)	EXCHANGE PARTS SET L1826	
2	CSA7768001	1	L1826-板R组件	L1826-PLATE R ASSY	
3	CSA7187001	1	压脚板组件 R1826	WORK CLAMP PLATE R1826 ASSY	
4	CSA7105001	1	针板 L1826R	NEEDLE PLATE L1826R	
5	CSA7095001	1	布压板 R-JL1826	WORK CLAMP R-JL1826	
6	CSA7186001	1	压脚板组件 L1826	WORK CLAMP PLATE L1826 ASSY	
7	CSA7100001	1	针板 L1826L	NEEDLE PLATE L1826L	
8	CSA7090001	1	布压板 L-JL1826	WORK CLAMP L-JL1826	
9	CS37706001	1	气锤 S20	HAMMER, S20	
10	CS37708001	1	气锤 S24	HAMMER, S24	



AA1. 附属装置 / Attachment set

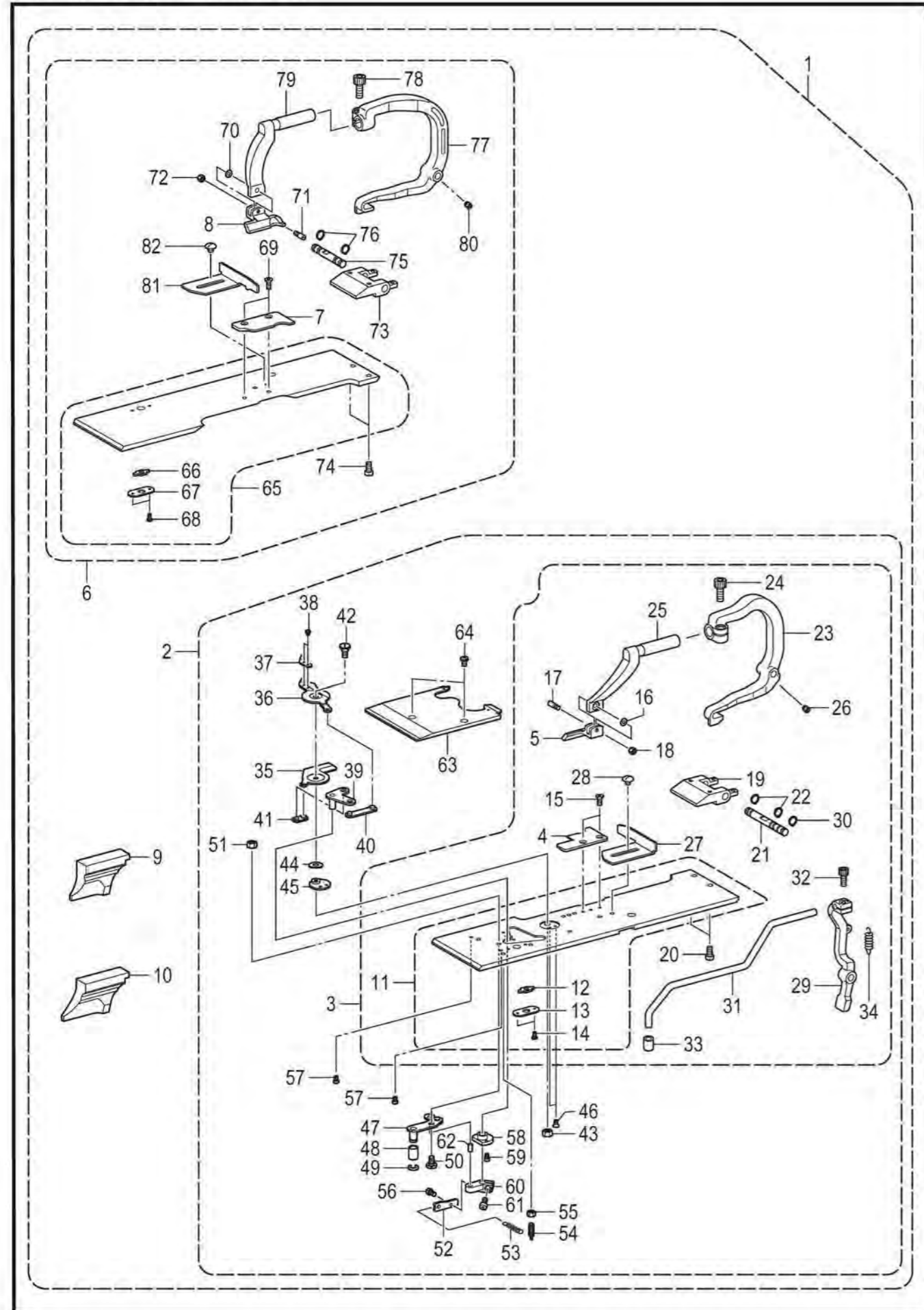

AA1. 附属装置 / Attachment set

参照号	零部件序号	数量	零部件名称	NAME OF PARTS	RM
11	CSA6729001	1	布压板组件 JR	WORK CLAMP PLATE JR UNIT	
12	CS35315001	1	角块	OPENING SLIDE BLOCK	
13	CS35316001	1	角块支撑板	SLIDE BLOCK SUPPORT PLATE	
14	C060020416	2	螺钉 M2X4	SCREW BIND M2X4	
15	CS06696004	2	螺钉 M3X6	SCREW, FLAT M3X6	
16	CS35236000	1	垫圈 3.2	WASHER, BENDING 3.2	
17	CS35235001	1	支架销	SUPPORT PIN, CLAMP	
18	C021300306	1	螺母 M3	NUT 3 M3	
19	CSA5560001	1	夹轴承受板	CLAMP SHAFT HOLDER	
20	C062400816	2	螺钉 M4X8	SCREW PAN M4X8	
21	CSA6733001	1	支点轴 J	CLAMP FULCRUM SHAFT J	
22	C048060142	2	轴用挡圈 C6	RETAINING RING EXTERNAL C6	
23	CSA5585001	1	夹杆 R	CLAMP LEVER R	
24	C018501236	1	螺栓 M5X12	BOLT SOCKET M5X12	
25	CSA6734001	1	夹臂 R-J	CLAMP ARM R-J	
26	C014400536	2	螺钉 M4X5	SET SCREW SOCKET(CP) M4X5	
27	CSA7550001	1	布挡板 R	CROTH GUIDE R	
28	CS35326101	1	螺钉 M3.5	SCREW M3.5	
29	CSA6735001	1	辅助压脚臂	AUX CLAMP ARM	
30	C048060142	1	轴用挡圈 C6	RETAINING RING EXTERNAL C6	
31	CSA6736001	1	辅助压脚杆	SUB AUX CLAMP WRIST	
32	C018401036	1	螺栓 M4X10	BOLT SOCKET M4X10	
33	CS05356000	1	扣夹 A	BUTTON CLAMP, A	
34	CSA6737001	1	回复弹簧	AUX CLAMP TSWIST SPRING	
35	CSA6988001	1	动刀 R	MOVABLE KNIFE R	
36	CSA6989001	1	动刀 L	MOVABLE KNIFE L	
37	CSA6990001	1	挡线器	THREAD HANDLER	
38	C153787001	2	螺钉 SM2.38	SCREW, SM2.38	
39	CSA6991001	1	动刀驱动板	MOVABLE KNIFE DRIVING PLATE	
40	CSA6992001	1	切线连接组件 A	THREAD TRIMMER LINK A ASSY	
41	CSA6994001	1	切线连接组件 B	THREAD TRIMMER LINK B ASSY	
42	CS37660101	1	段螺钉 M4	SHOULDER SCREW, M4	
43	C021400206	1	六角螺母 M4	NUT 2 M4	
44	CS37654000	1	波纹垫圈	WAVE WASHER	
45	CS37655101	1	切刀支撑圈	KNIFE SUPPORT WASHER	
46	C141542001	2	螺钉 3.18	SCREW 3.18	
47	CSA6996001	1	切线连接杆组件 J	THREAD TRIMMER L-LEVER J ASSY	
48	CSA7778001	1	连接杆滚轮	LINK LEVER ROLLER	
49	C137191051	1	挡圈	STOP RING	
50	CSA5693001	1	段螺钉 M4	SHOULDER SCREW M4	
51	C021400306	1	六角螺母 M4	NUT 3 M4	
52	CSA6998001	1	弹簧挂钩	SPRING HOOK	
53	CSA6999001	1	切线弹簧	THREAD TRIMMER SPRING	
54	CS34902001	1	弹簧挂钩	SPRING HOOK	
55	C021350106	1	螺母 M3.5	NUT 1 M3.5	
56	C062260406	1	螺钉 M2.6X4	SCREW PAN M2.6X4	
57	C062300416	2	螺钉 M3X4	SCREW PAN M3X4	
58	CSA7001001	1	切线臂管套	BUSH TR TRIMMER ARM	
59	C062260516	2	螺钉 M2.6X5	SCREW PAN M2.6X5	
60	CSA7002001	1	切线杆臂 B	THREAD TRIMMER LEVER ARM B	
61	CS21716001	1	螺钉 M4X10	SCREW, BUTTON HEAD M4X10	
62	CS37858000	1	针销 4X8	NEEDLE PIN, 4X8	
63	CSA7003001	1	压板 JU	WORK CLAMP PLATE JU	
64	C060400516	2	螺钉 M4X5	SCREW BIND M4X5	
65	CSA6739001	1	布压板组件 JL	WORK CLAMP PLATE JL ASSY	
66	CS35315001	1	角块	OPENING SLIDE BLOCK	
67	CS35316001	1	角块支撑板	SLIDE BLOCK SUPPORT PLATE	
68	C060020416	2	螺钉 M2X4	SCREW BIND M2X4	
69	CS06696004	2	螺钉 M3X6	SCREW, FLAT M3X6	
70	CS35236000	1	垫圈 3.2	WASHER, BENDING 3.2	
71	CS35235001	1	支架销	SUPPORT PIN, CLAMP	
72	C021300306	1	螺母 M3	NUT 3 M3	
73	CSA5560001	1	夹轴承受板	CLAMP SHAFT HOLDER	



AA1. 附属装置 / Attachment set

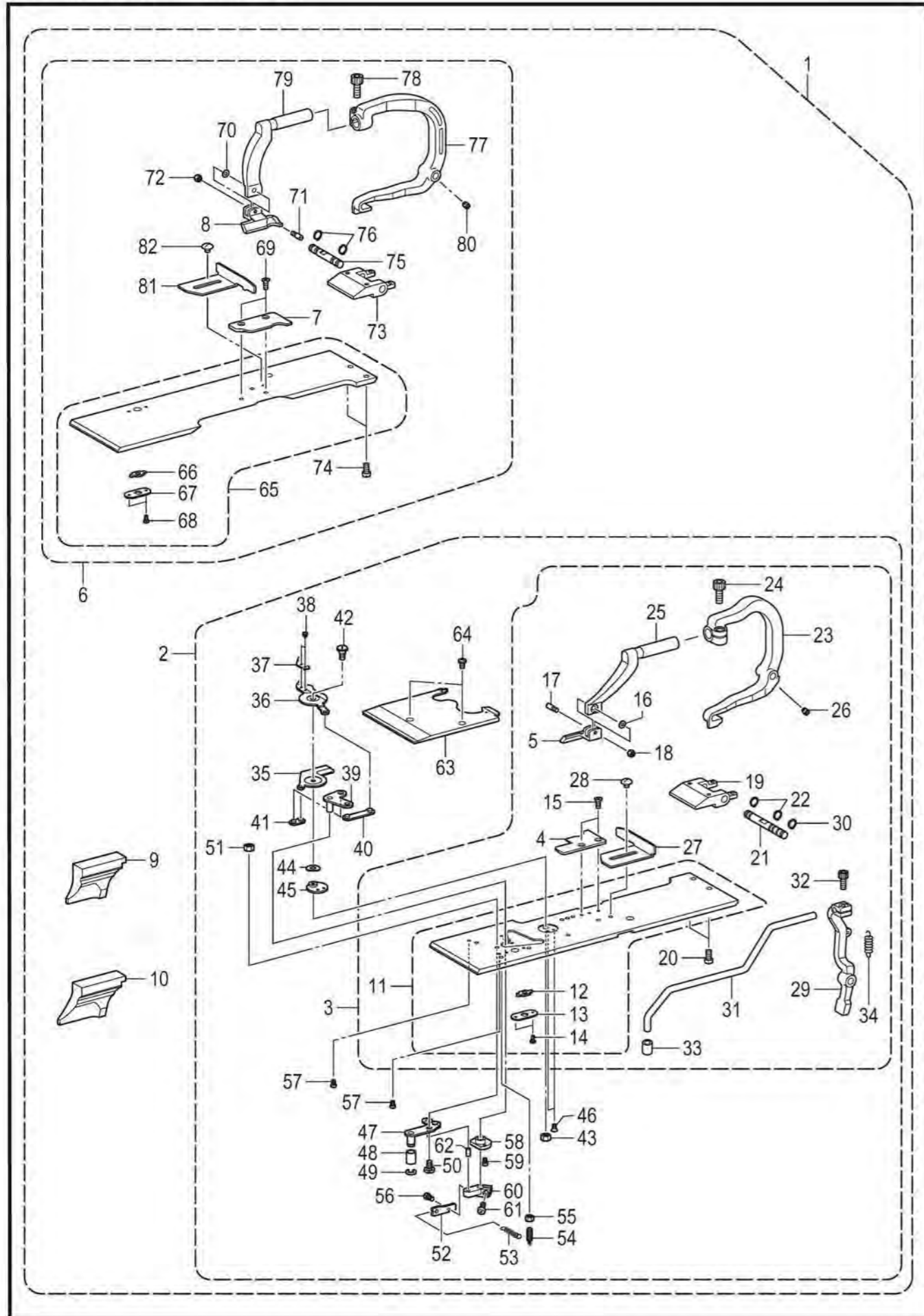

AA1. 附属装置 / Attachment set

参照号	零部件序号	数量	零部件名称	NAME OF PARTS	RM
74	C062400816	2	螺钉 M4X8	SCREW PAN M4X8	
75	CSA5674001	1	支点轴	CLAMP FULCRUM SHAFT	
76	C048060142	2	轴用挡圈 C6	RETAINING RING EXTERNAL C6	
77	CSA5671001	1	夹杆 L	CLAMP LEVER L	
78	C018501236	1	螺栓 M5X12	BOLT SOCKET M5X12	
79	CSA6743001	1	夹臂 L-J	CLAMP ARM L-J	
80	C014400536	2	螺钉 M4X5	SET SCREW SOCKET(CP) M4X5	
81	CSA7551001	1	布挡板 L	CROTH GUIDE L	
82	CS35326101	1	螺钉 M3.5	SCREW M3.5	



AA2. 附属装置 / Attachment set

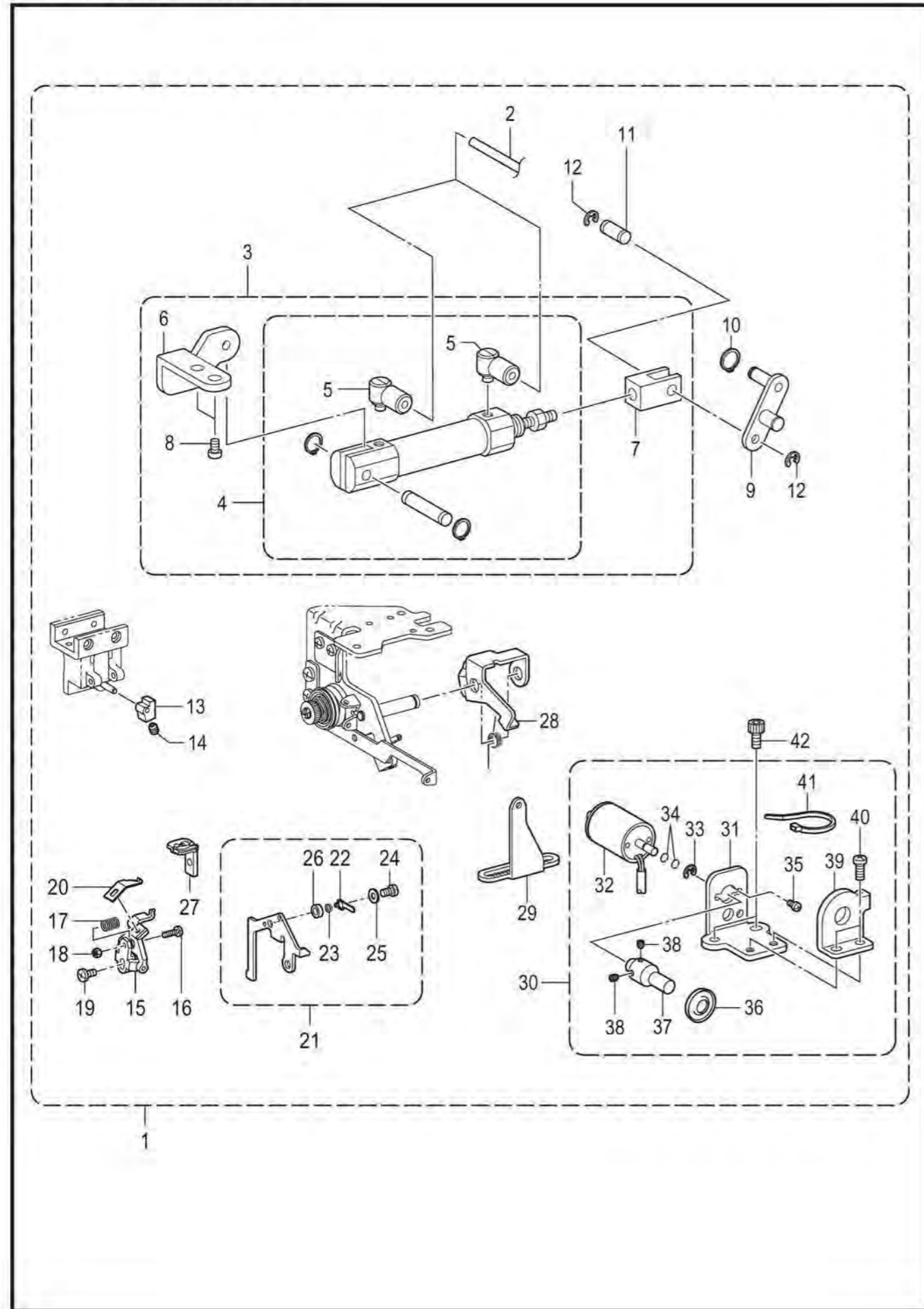

AA2. 附属装置 / Attachment set

参照号	零部件序号	数量	零部件名称	NAME OF PARTS	RM
			<规格变换用零部件> <用于-01变更为-02规格时>	<For exchange parts> <Exchange parts from -01 to -02>	
1	CSA7773001	1	规格变换零部件组 (-2)	EXCHANGE PARTS SET -2	
2	CSA7131001	2	空气管 4X2.5-150	AIR TUBE 4X2.5-150	
3	CSA6718001	1	辅助压脚气缸组件	AUX CLAMP C-SUPPORT ASSY	
4	CSA6719001	1	气缸组件 10X15	CYLINDER ASSY 10X15	
5	CS12150000	2	管接头 M-5HL-4	TUBE ELBOW, M-5HL-4	
6	CSA6720001	1	辅助压脚 S 支架	AUX CLAMP S HOLDER	
7	CS35351001	1	气缸杆	CYLINDER ROD	
8	C062400816	2	螺钉 M4X8	SCREW PAN M4X8	
9	CSA6721001	1	气缸杆销	AUX CLAMP CONNECTING ROD ASSY	
10	C048050142	1	轴用挡圈 C5	RETAINING RING EXTERNAL C5	
11	CSA6726001	1	气缸连杆销	CYLINDER ROD PIN	
12	C048030342	2	挡圈 E3	RETAINING RING E3	
13	CSA6800001	1	气锤垫块	HAMMER SPACER	
14	C014400536	1	螺钉 M4X5	SET SCREW SOCKET (CP) M4X5	
15	CSA6868001	1	底线压板组件 J	LOWER THREAD PRESSER J ASSY	
16	CS37724001	1	螺钉 SM2.38	SCREW, SM2.38	
17	CS37725001	1	底线压簧	COMPRESSIONSPRING	
18	CS47932001	1	螺母 SM2.38-56	NUT, SM2.38-56	
19	C060300816	1	螺钉 M3X8	SCREW BIND M3X8	
20	CS37723101	1	上动刀 B	UPPER MOVABLE KNIFE, B	
21	CSA6873001	1	芯线导向组件 C-J	GIMP THREAD GUIDE C-J ASSY	
22	CSA7613001	1	芯线压板	GIMP THREAD CLAMP PLATE	
23	CSA7614001	1	芯线调节弹簧	GIMP THREAD TENSION SPRING	
24	C062300506	1	螺钉 M3X5	SCREW PAN M3X5	
25	C025030236	1	平垫圈 M3	WASHER PLAIN M 3	
26	CSA7615001	1	管套 3	COLLAR 3	
27	CS37752001	1	针孔板 1.8-J	THROAT PLATE, 1.8-J	
28	CSA7067101	1	底线松线板	L-THREAD RELEASE PLATE	
29	CSA6982001	1	芯线导向 J	GIMP THREAD GUIDE J	
30	CSA6983001	1	芯线夹组件	GIMP THREAD CLAMP ASSY	
31	CSA6984001	1	芯线夹板	GIMP THREAD CLAMP PLATE	
32	CSA6537001	1	芯线电磁铁	GIMP THREAD SOLENOID	
33	C048025346	1	挡圈 E2.5	RETAINING RING E2.5	
34	C081003870	2	O形圈 S3	O RING S3	
35	C062260406	2	螺钉 M2.6X4	SCREW PAN M2.6X4	
36	C145446001	1	夹线盘	DISC, TENSION	
37	CSA6986001	1	芯线轴	GIMP THREAD SHAFT	
38	C014300332	2	螺钉 M3X3	SET SCREW SOCKET (CP) M3X3	
39	CSA6987001	1	芯线夹	GIMP THREAD CLAMP	
40	C062400816	2	螺钉 M4X8	SCREW PAN M4X8	
41	CS04557000	1	电线夹 PLT1M	BAND PLT1M	
42	C018400836	2	螺栓 M4X8	BOLT SOCKET M4X8	



AA3 . 附属装置 / Attachment set

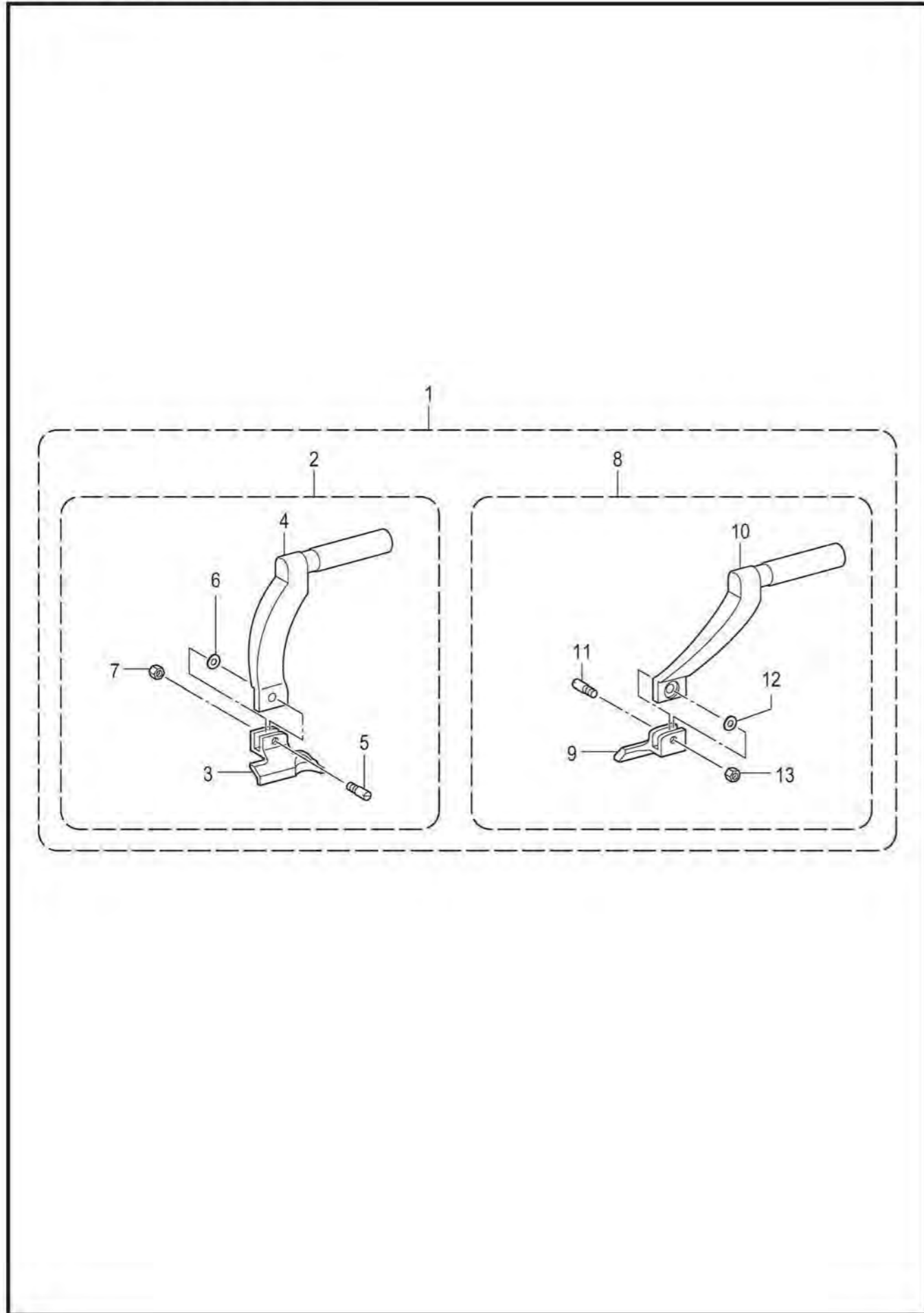

AA3. 附属装置 / Attachment set

参照号	零部件序号	数量	零部件名称	NAME OF PARTS	RM
			<用于腰带压脚 L26>	<For waist belt presser L26>	
1	CSA7777001	1	压脚复合件 L26W	WORK CLAMP SET L26W	
2	CSA7775001	1	压脚组件 L-L26W	WORK CLAMP ASSY L-L26W	
3	CS43408001	1	压脚 L-L3W	WORK CLAMP, L-L3W	
4	CSA7726001	1	夹臂 L-JW	CLAMP ARM L-JW	
5	CS35235001	1	支架销	SUPPORT PIN, CLAMP	
6	CS35236000	1	垫圈 3.2	WASHER, BENDING 3.2	
7	C021300306	1	螺母 M3	NUT 3 M3	
8	CSA7776001	1	压脚组件 R-L26W	WORK CLAMP ASSY R-L26W	
9	CS43409001	1	压脚 R-L3W	WORK CLAMP, R-L3W	
10	CSA7727001	1	夹臂 R-JW	CLAMP ARM R-JW	
11	CS35235001	1	支架销	SUPPORT PIN, CLAMP	
12	CS35236000	1	垫圈 3.2	WASHER, BENDING 3.2	
13	C021300306	1	螺母 M3	NUT 3 M3	
			<用于腰带压脚 L30>	<For waist belt presser L30>	
1	CSA7781001	1	压脚复合件 L30W	WORK CLAMP SET L30W	
2	CSA7779001	1	压脚组件 L-L30W	WORK CLAMP ASSY L-L30W	
3	CS43410001	1	压脚 L-L4W	WORK CLAMP, L-L4W	
4	CSA7726001	1	夹臂 L-JW	CLAMP ARM L-JW	
5	CS35235001	1	支架销	SUPPORT PIN, CLAMP	
6	CS35236000	1	垫圈 3.2	WASHER, BENDING 3.2	
7	C021300306	1	螺母 M3	NUT 3 M3	
8	CSA7780001	1	压脚组件 R-L30W	WORK CLAMP ASSY R-L30W	
9	CS43411001	1	压脚 R-L4W	WORK CLAMP, R-L4W	
10	CSA7727001	1	夹臂 R-JW	CLAMP ARM R-JW	
11	CS35235001	1	支架销	SUPPORT PIN, CLAMP	
12	CS35236000	1	垫圈 3.2	WASHER, BENDING 3.2	
13	C021300306	1	螺母 M3	NUT 3 M3	



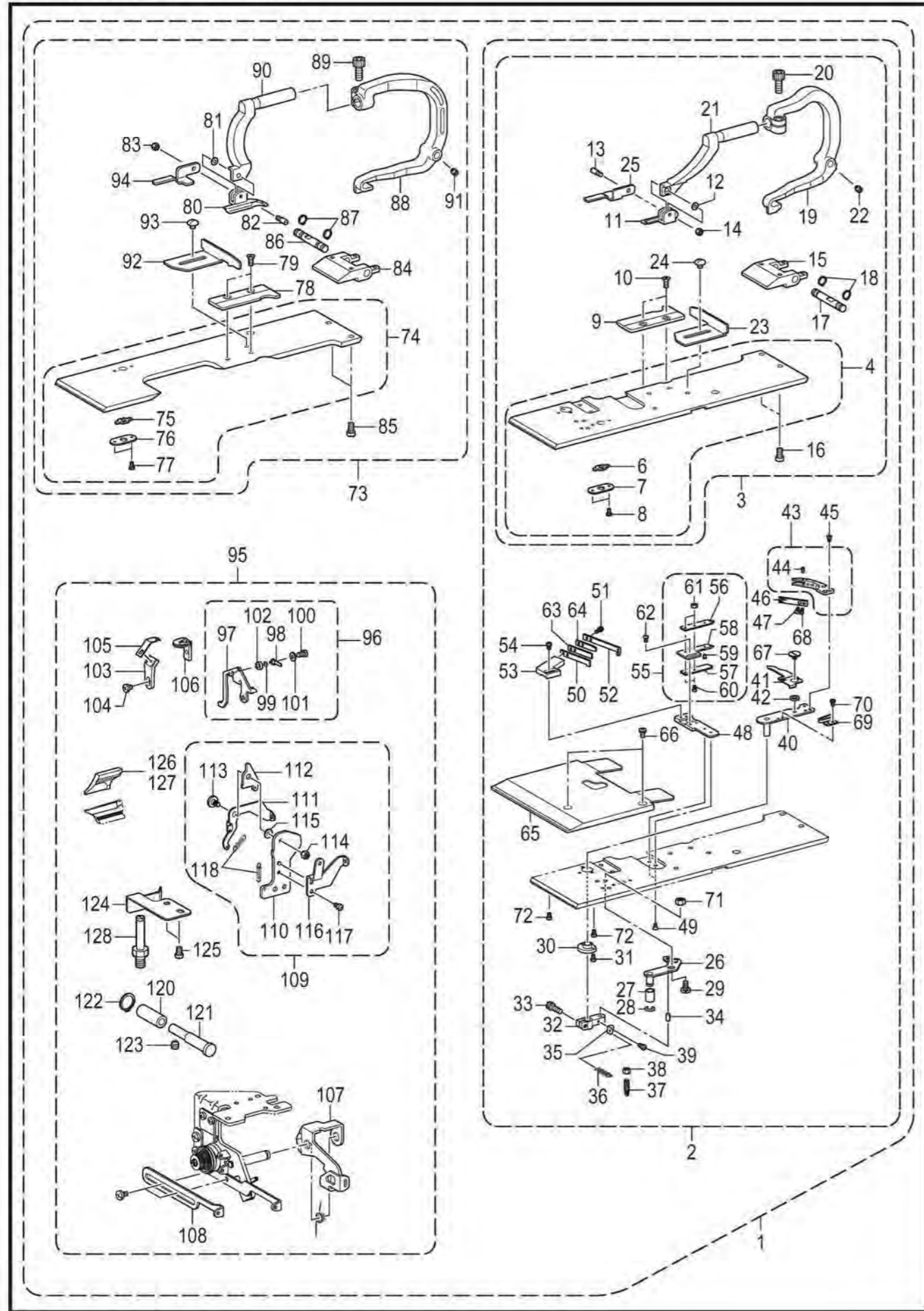

参照号	零部件序号	数量	零部件名称	NAME OF PARTS	RM
			<规格变换用零部件> <用于-02变更为-01规格时>	<For exchange parts> <Exchange parts from -02 to -01>	
1	CSA7784001	1	规格变换零部件组 01	EXCHANGE PARTS SET 01	
2	CSA7782001	1	板RS组件 (-01)	PLATE ASSY RS 01	
3	CSA7055001	1	压脚板总组件 RS30	WORK CLAMP PLATE RS30 UNIT	
4	CSA7056001	1	布压板组件 RS	WORK CLAMP PLATE RS ASSY	
6	CS35315001	1	角块	OPENING SLIDE BLOCK	
7	CS35316001	1	角块支撑板	SLIDE BLOCK SUPPORT PLATE	
8	C060020416	2	螺钉 M2X4	SCREW BIND M2X4	
9	CSA5673001	1	针板 R-42	NEEDLE PLATE R-42	
10	CS06696004	2	螺钉 M3X6	SCREW, FLAT M3X6	
11	CS39932101	1	压布 R-30	CLOTH WORK CLAMP, R-30	
12	CS35236000	1	垫圈 3.2	WASHER, BENDING 3.2	
13	CS35235001	1	支架销	SUPPORT PIN, CLAMP	
14	C021300306	1	螺母 M3	NUT 3 M3	
15	CSA5560001	1	夹轴承受板	CLAMP SHAFT HOLDER	
16	C062400816	2	螺钉 M4X8	SCREW PAN M4X8	
17	CSA5674001	1	支点轴	CLAMP FULCRUM SHAFT	
18	C048060142	2	轴用挡圈 C6	RETAINING RING EXTERNAL C6	
19	CSA5585001	1	夹杆 R	CLAMP LEVER R	
20	C018501236	1	螺栓 M5X12	BOLT SOCKET M5X12	
21	CSA5576001	1	夹臂 R	CLAMP ARM R	
22	C014400536	2	螺钉 M4X5	SET SCREW SOCKET(CP) M4X5	
23	CSA7550001	1	布挡板 R	CROTH GUIDE R	
24	CS35326101	1	螺钉 M3.5	SCREW M3.5	
25	CS35330001	1	压料板 R	WORK CLAMP PLATE, R	
26	CSA7526001	1	切线连接杆组件	THREAD TRIMMER LINK LEVER ASSY	
27	CSA7778001	1	连接杆滚轮	LINK LEVER ROLLER	
28	C137191051	1	挡圈	STOP RING	
29	CSA5693001	1	段螺钉 M4	SHOULDER SCREW M4	
30	CS34906100	1	切线臂管套	BUSH TR TRIMMER ARM	
31	C062260516	2	螺钉 M2.6X5	SCREW PAN M2.6X5	
32	CS34905101	1	切线杆臂	THREAD CUTTER LEVER ARM	
33	C018401036	1	螺栓 M4X10	BOLT SOCKET M4X10	
34	CS37858000	1	针销 4X8	NEEDLE PIN, 4X8	
35	CS34903001	1	弹簧挂钩	SPRING HOOK	
36	CS34883001	1	切线弹簧	SPRING, EXTENSION	
37	CS34902001	1	弹簧挂钩	SPRING HOOK	
38	C021350106	1	螺母 M3.5	NUT 1 M3.5	
39	C062260406	1	螺钉 M2.6X4	SCREW PAN M2.6X4	
40	CS34901001	1	切线臂	THREAD TRIMMER ARM	
41	CS34900001	1	分线板	OPENER, T-NIPPER	
42	C153219001	1	动刀管套	COLLAR, MOVABLE KNIFE	
43	CS34899001	1	动刀组件	MOVABLE KNIFE ASSY	
44	CS34898001	1	弹簧销 1.4	PIN, SPRING 1.4	
45	C141542001	3	螺钉 3.18	SCREW 3.18	
46	CSA7076001	1	挡线器	THREAD HANDLER	
47	CS01694001	1	螺钉 SM2.38X4	SCREW, FLAT SM2.38X4	
48	CS34896001	1	定刀台座	BRACKET, FIXED KNIFE	
49	C061300416	2	螺钉 M3X4	SCREW FLAT M3X4	
50	CS34895001	1	定刀	FIXED KNIFE	
51	C018260832	2	螺栓 M2.6X8	BOLT, SOCKET M2.6X8	
52	CS34894001	1	线导向板	THREAD GUIDE PLATE	
53	CS34893001	1	定刀安装板	SETTING BRACKET FIXED KNIFE	
54	C062300512	2	螺钉 M3X5	SCREW PAN M3X5	
55	CS34889101	1	夹线组件	THREAD NIPPER ASSY	
56	CS34890001	1	夹线 U	THREAD NIPPER, U	
57	CS34891101	1	夹线 D	THREAD NIPPER, D	
58	CS34888101	1	夹线 M	THREAD NIPPER, M	
59	CS34892001	1	分线销	OPENER PIN	
60	C062020416	2	螺钉 M2X4	SCREW PAN M2X4	
61	C021020106	2	螺母 M2	NUT 1 M2	



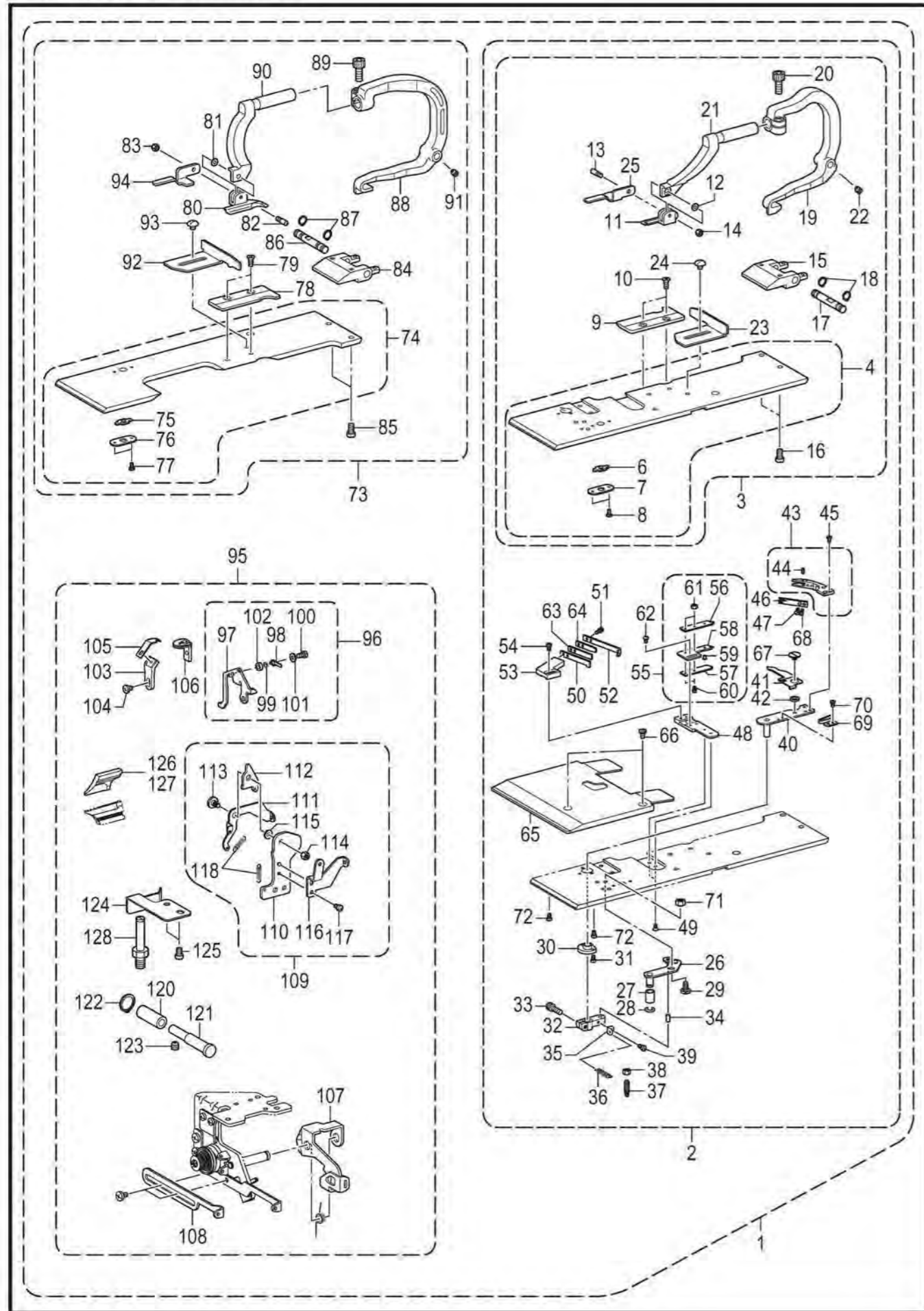

参照号	零部件序号	数量	零部件名称	NAME OF PARTS	RM
62	C542515001	2	螺母 M2.6X3.5	SCREW M2.6X3.5	
63	CS34887001	1	定刀板弹簧	SPRING, PLATE ;F-KNIFE	
64	CS34886001	1	定刀板弹簧 U	SPRING, U PLATE ;F-KNIFE	
65	CSA7077001	1	压板 U	PRESSER PLATE U	
66	C060400516	2	螺钉 M4X5	SCREW BIND M4X5	
67	C152904001	1	螺钉 SM4.37	SCREW, SM4.37	
68	C104336003	1	螺钉 SM2.38	SCREW, SM2.38	
69	CS34884000	1	分线器弹簧	OPENER SPRING	
70	C060630312	2	螺钉 SM2.38-56X3	SCREW BIND SM2.38-56X3	
71	C021400306	1	六角螺母 M4	NUT 3 M4	
72	C062300416	2	螺钉 M3X4	SCREW PAN M3X4	
73	CSA7060001	1	压脚板总组件 LS30	WORK CLAMP PLATE LS30 UNIT	
74	CSA7061001	1	布压板组件 LS	WORK CLAMP PLATE LS ASSY	
75	CS35315001	1	角块	OPENING SLIDE BLOCK	
76	CS35316001	1	角块支撑板	SLIDE BLOCK SUPPORT PLATE	
77	C060020416	2	螺钉 M2X4	SCREW BIND M2X4	
78	CSA5672001	1	针板 L-42	NEEDLE PLATE L-42	
79	CS06696004	2	螺钉 M3X6	SCREW, FLAT M3X6	
80	CS39931101	1	压布 L-30	CLOTH WORK CLAMP, L-30	
81	CS35236000	1	垫圈 3.2	WASHER, BENDING 3.2	
82	CS35235001	1	支架销	SUPPORT PIN, CLAMP	
83	C021300306	1	螺母 M3	NUT 3 M3	
84	CSA5560001	1	夹轴承受板	CLAMP SHAFT HOLDER	
85	C062400816	2	螺钉 M4X8	SCREW PAN M4X8	
86	CSA5674001	1	支点轴	CLAMP FULCRUM SHAFT	
87	C048060142	2	轴用挡圈 C6	RETAINING RING EXTERNAL C6	
88	CSA5671001	1	夹杆 L	CLAMP LEVER L	
89	C018501236	1	螺栓 M5X12	BOLT SOCKET M5X12	
90	CSA5577001	1	夹臂 L	CLAMP ARM L	
91	C014400536	2	螺钉 M4X5	SET SCREW SOCKET(CP) M4X5	
92	CSA7551001	1	布挡板 L	CROTH GUIDE L	
93	CS35326101	1	螺钉 M3.5	SCREW M3.5	
94	CS35329001	1	压料板 L	WORK CLAMP PLATE, L	
95	CSA7783001	1	变换零部件组 01	EXCHANGE PARTS SET 01	
96	CSA7578001	1	芯线导向组件 C	GIMP THREAD GUIDE C ASSY	
97	CSA7063001	1	芯线导向 C	GIMP THREAD GUIDE C	
98	CSA7613001	1	芯线压板	GIMP THREAD CLAMP PLATE	
99	CSA7614001	1	芯线调节弹簧	GIMP THREAD TENSION SPRING	
100	C062300506	1	螺钉 M3X5	SCREW PAN M3X5	
101	C025030236	1	平垫圈 M3	WASHER PLAIN M 3	
102	CSA7615001	1	管套 3	COLLAR 3	
103	CSA7064001	1	上动刀台	UPPER MOVABLE KNIFE	
104	C060300416	1	螺钉 M3X4	SCREW BIND M3X4	
105	CS35029001	1	上动刀 A	UPPER MOVABLE KNIFE, A	
106	CSA7065001	1	针孔板 1.6	THROAT PLATE 1.6	
107	CSA6971001	1	底线取线手柄	L-THREAD TAKE-UP GUIDE LENER	
108	CSA6974001	1	底线导向 C	LOWER THREAD GUIDE C	
109	CSA7068001	1	芯线过线手柄组件	GIMP THREAD TAKE-UP G-L ASSY	
110	CSA7069001	1	芯线过线架	GIMP THREAD TAKE-UP G-HOLDER	
111	CSA7070001	1	芯线过线板	G-THREAD TAKE-UP GUIDE PLATE	
112	CSA7071001	1	芯线过线作动板	GIMP THREAD TAKE-UP G-E PLATE	
113	CSA7072001	1	段螺钉 M4	SHOULDER SCREW M4	
114	C021400306	1	六角螺母 M4	NUT 3 M4	
115	C158722001	1	垫圈 4.2	WASHER PLAIN 4.2	
116	CSA7073001	1	芯线导向	GIMP THREAD GUIDE	
117	C062300416	1	螺钉 M3X4	SCREW PAN M3X4	
118	CSA7074001	2	弹簧	SPRING TORSION	
120	CSA7053001	1	轴套	G-THREAD TAKE-UP GUIDE COLLER	
121	CSA7054001	1	短轴	G-THREAD TAKE-UP GUIDE SHAFT	
122	C048050142	1	轴用挡圈 C5	RETAINING RING EXTERNAL C5	
123	C014400536	1	螺钉 M4X5	SET SCREW SOCKET(CP) M4X5	



AA4. 附属装置 / Attachment set

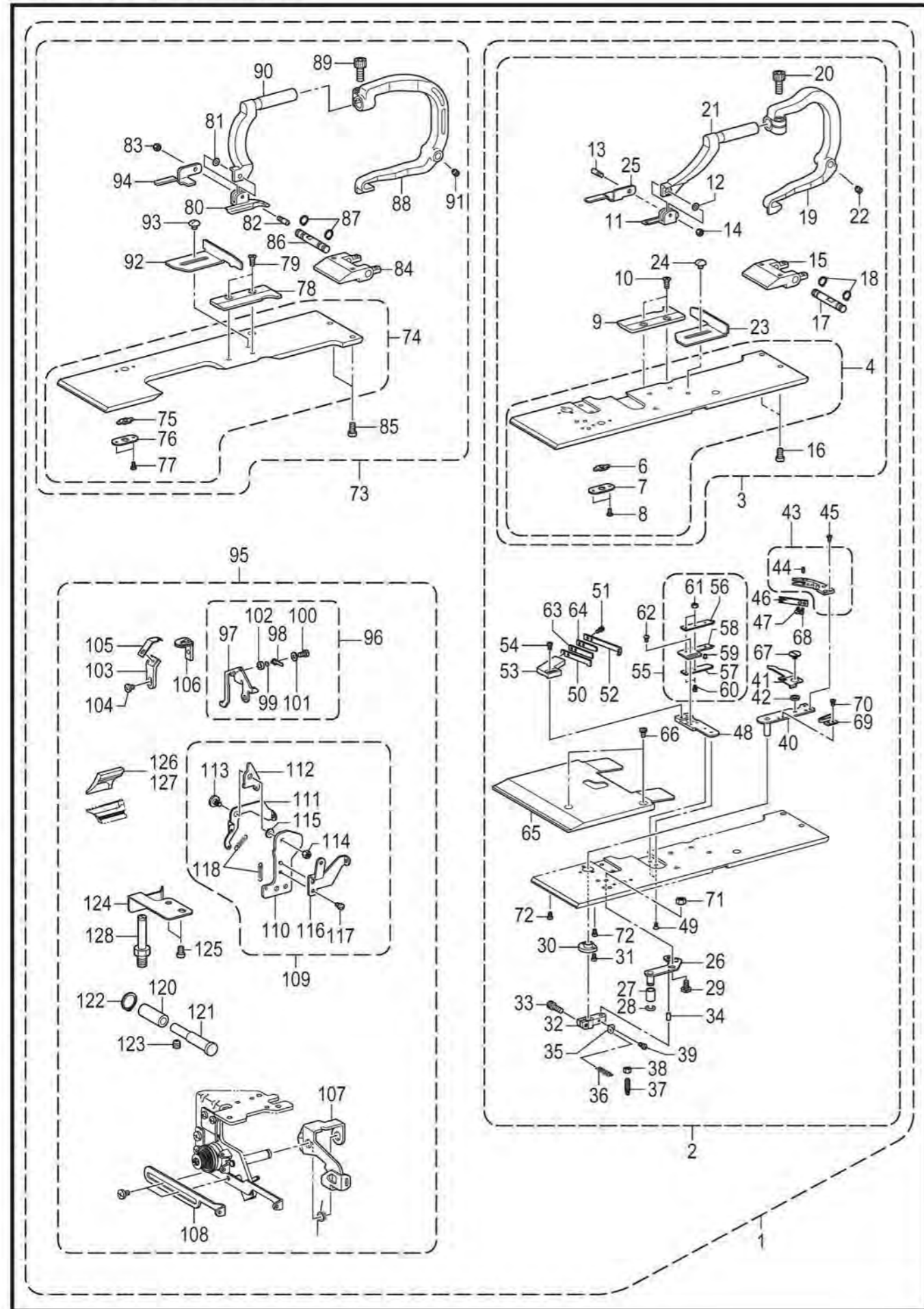

AA4. 附属装置 / Attachment set

参照号	零部件序号	数量	零部件名称	NAME OF PARTS	RM
124	CSA7555001	1	板弹簧	FEED BAR PLATE SPRING	
125	C062400816	2	螺钉 M4X8	SCREW PAN M4X8	
126	CS37195001	1	气锤 22	HAMMER, 22	
127	CS37199001	1	气锤 30	HAMMER, 30	
128	CSA5584001	1	气缸螺栓	CYLINDER SCREW	



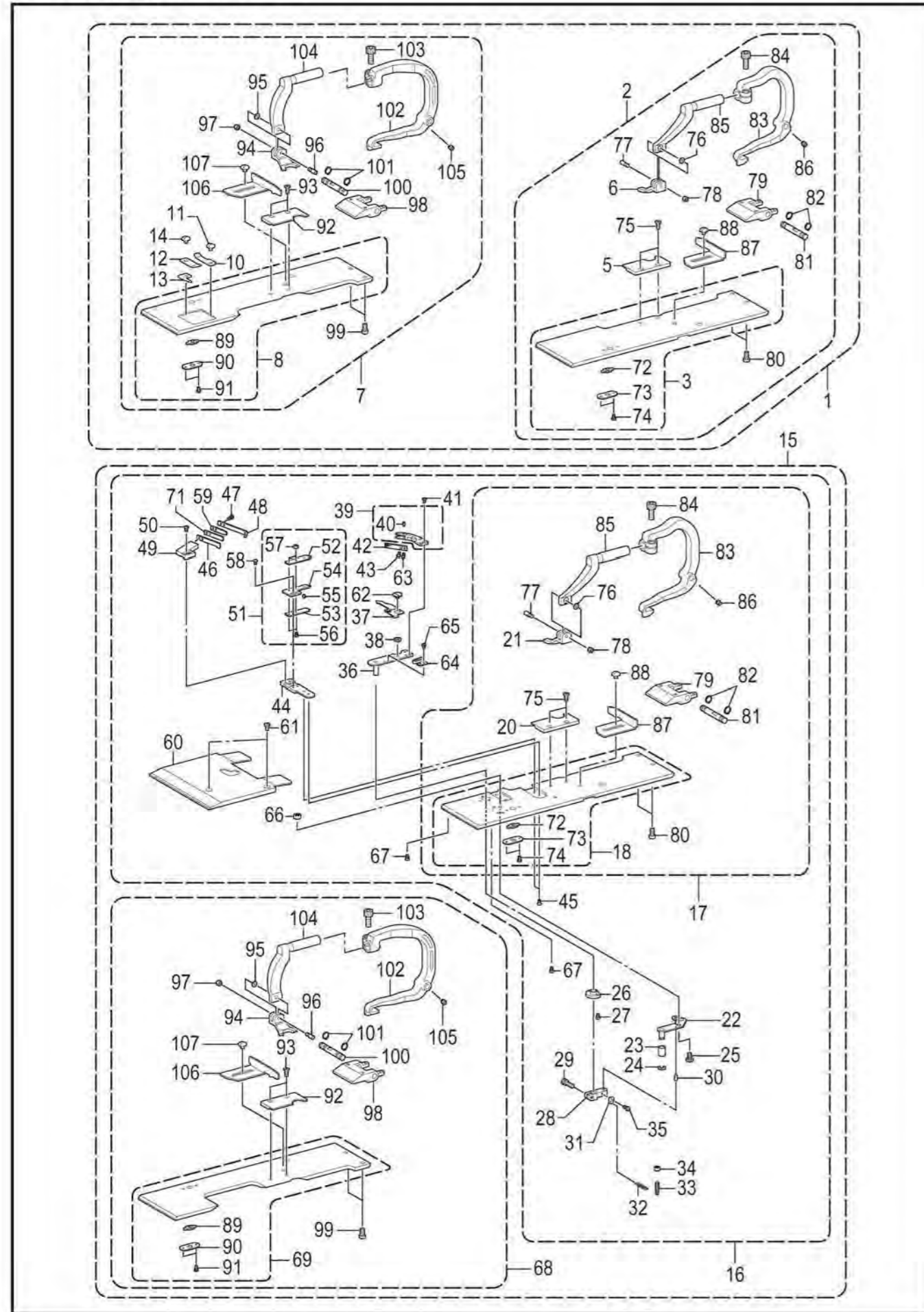

参照号	零部件序号	数量	零部件名称	NAME OF PARTS	RM
			<用于-00菊孔复合件>	<For -00 circular stitch set>	
1	CSA7804001	1	菊孔变换零部件组 D13 00	EXCHANGE PARTS SET D13 00	
2	CSA7802001	1	布压板RD13组件	WORK CLAMP PLATE ASSY RD13	
3	CSA7080001	1	布压板组件 R	WORK CLAMP PLATE R ASSY	
5	CS41340001	1	针板 RD13	NEEDLE PLATE, RD13	
6	CS41337001	1	压脚 D13	WORK CLAMP, D13	
7	CSA7803101	1	布压板LD13组件	WORK CLAMP PLATE ASSY LD13	
8	CSA7083001	1	布压板组件 L	WORK CLAMP PLATE L ASSY	
10	CSA7149001	1	板弹簧	PLATE SPRING	
11	CS35326101	1	螺钉 M3.5	SCREW M3.5	
12	CSA7150101	1	切线 A	THREAD TRIMMER A	
13	CSA7151101	1	切线 B	THREAD TRIMMER B	
14	CS35326101	1	螺钉 M3.5	SCREW M3.5	
			<用于-01菊孔复合件>	<For -01 circular stitch set>	
15	CSA7808001	1	菊孔变换零部件组 SD13 01	EXCHANGE PARTS SET SD13 01	
16	CSA7806001	1	压板RSD13组件	PLATE RSD13 ASSY	
17	CSA7805001	1	布压板RSD13组件	WORK CLAMP PLATE ASSY RSD13	
18	CSA7056001	1	布压板组件 RS	WORK CLAMP PLATE RS ASSY	
20	CS41340001	1	针板 RD13	NEEDLE PLATE, RD13	
21	CS41337001	1	压脚 D13	WORK CLAMP, D13	
22	CSA7526001	1	切线连接杆组件	THREAD TRIMMER LINK LEVER ASSY	
23	CSA7778001	1	连接杆滚轮	LINK LEVER ROLLER	
24	C137191051	1	挡圈	STOP RING	
25	CSA5693001	1	段螺钉 M4	SHOULDER SCREW M4	
26	CS34906100	1	切线臂管套	BUSH TR TRIMMER ARM	
27	C062260516	2	螺钉 M2.6X5	SCREW PAN M2.6X5	
28	CS34905101	1	切线杆臂	THREAD CUTTER LEVER ARM	
29	C018401036	1	螺栓 M4X10	BOLT SOCKET M4X10	
30	CS37858000	1	针销 4X8	NEEDLE PIN, 4X8	
31	CS34903001	1	弹簧挂钩	SPRING HOOK	
32	CS34883001	1	切线弹簧	SPRING, EXTENSION	
33	CS34902001	1	弹簧挂钩	SPRING HOOK	
34	C021350106	1	螺母 M3.5	NUT 1 M3.5	
35	C062260406	1	螺钉 M2.6X4	SCREW PAN M2.6X4	
36	CS34901001	1	切线臂	THREAD TRIMMER ARM	
37	CS34900001	1	分线板	OPENER, T-NIPPER	
38	C153219001	1	动刀管套	COLLAR, MOVABLE KNIFE	
39	CS34899001	1	动刀组件	MOVABLE KNIFE ASSY	
40	CS34898001	1	弹簧销 1.4	PIN, SPRING 1.4	
41	C141542001	3	螺钉 3.18	SCREW 3.18	
42	CSA7076001	1	挡线器	THREAD HANDLER	
43	CS01694001	1	螺钉 SM2.38X4	SCREW, FLAT SM2.38X4	
44	CS34896001	1	定刀台座	BRACKET, FIXED KNIFE	
45	C061300416	2	螺钉 M3X4	SCREW FLAT M3X4	
46	CS34895001	1	定刀	FIXED KNIFE	
47	C018260832	2	螺栓 M2.6X8	BOLT, SOCKET M2.6X8	
48	CS34894001	1	线导向板	THREAD GUIDE PLATE	
49	CS34893001	1	定刀安装板	SETTING BRACKET FIXED KNIFE	
50	C062300512	2	螺钉 M3X5	SCREW PAN M3X5	
51	CS34889101	1	夹线组件	THREAD NIPPER ASSY	
52	CS34890001	1	夹线 U	THREAD NIPPER, U	
53	CS34891101	1	夹线 D	THREAD NIPPER, D	
54	CS34888101	1	夹线 M	THREAD NIPPER, M	
55	CS34892001	1	分线销	OPENER PIN	
56	C062020416	2	螺钉 M2X4	SCREW PAN M2X4	
57	C021020106	2	螺母 M2	NUT 1 M2	
58	C542515001	2	螺母 M2.6X3.5	SCREW M2.6X3.5	
59	CS34886001	1	定刀板弹簧 U	SPRING, U PLATE F-KNIFE	
60	CSA7077001	1	压板 U	PRESSER PLATE U	
61	C060400516	2	螺钉 M4X5	SCREW BIND M4X5	
62	C152904001	1	螺钉 SM4.37	SCREW, SM4.37	
63	C104336003	1	螺钉 SM2.38	SCREW, SM2.38	
64	CS34884000	1	分线器弹簧	OPENER SPRING	



AA5 . 附属装置 / Attachment set

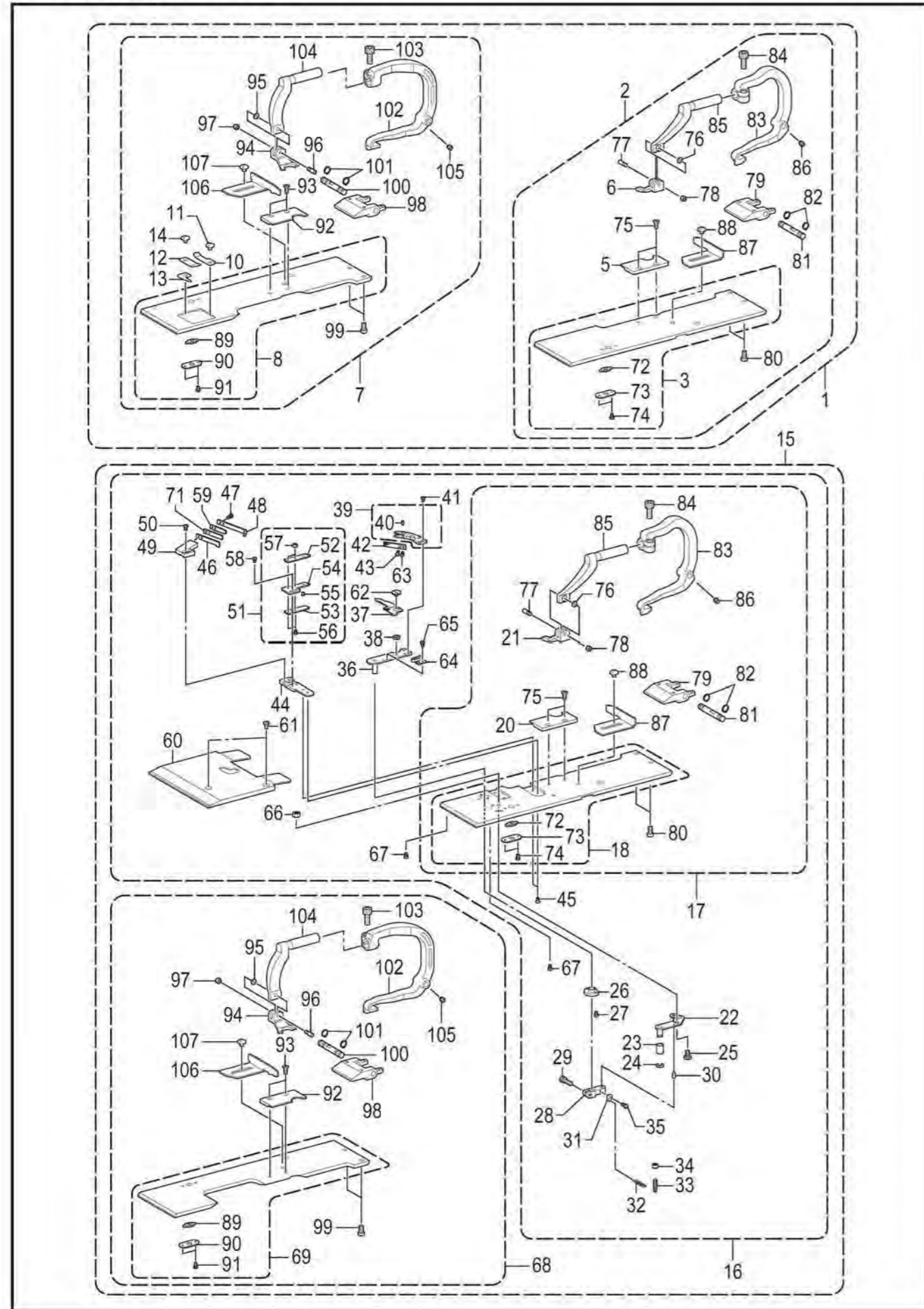

AA5. 附属装置 / Attachment set

参照号	零部件序号	数量	零部件名称	NAME OF PARTS	RM
			<用于-01菊孔复合件>	<For -01 circular stitch set>	
65	C060630312	2	螺钉 SM2.38-56X3	SCREW BIND SM2.38-56X3	
66	C021400306	1	六角螺母 M4	NUT 3 M4	
67	C062300416	2	螺钉 M3X4	SCREW PAN M3X4	
68	CSA7807001	1	布压板LSD13组件	WORK CLAMP PLATE ASSY LSD13	
69	CSA7061001	1	布压板组件 LS	WORK CLAMP PLATE LS ASSY	
71	CS34887001	1	定刀板弹簧	SPRING, PLATE ;F-KNIFE	
72	CS35315001	1	角块	OPENING SLIDE BLOCK	
73	CS35316001	1	角块支撑板	SLIDE BLOCK SUPPORT PLATE	
74	C060020416	2	螺钉 M2X4	SCREW BIND M2X4	
75	CS06696004	2	螺钉 M3X6	SCREW, FLAT M3X6	
76	CS35236000	1	垫圈 3.2	WASHER, BENDING 3.2	
77	CS35235001	1	支架销	SUPPORT PIN, CLAMP	
78	C021300306	1	螺母 M3	NUT 3 M3	
79	CSA5560001	1	夹轴承受板	CLAMP SHAFT HOLDER	
80	C062400816	2	螺钉 M4X8	SCREW PAN M4X8	
81	CSA5674001	1	支点轴	CLAMP FULCRUM SHAFT	
82	C048060142	2	轴用挡圈 C6	RETAINING RING EXTERNAL C6	
83	CSA5585001	1	夹杆 R	CLAMP LEVER R	
84	C018501236	1	螺栓 M5X12	BOLT SOCKET M5X12	
85	CSA6734001	1	夹臂 R-J	CLAMP ARM R-J	
86	C014400536	2	螺钉 M4X5	SET SCREW SOCKET(CP) M4X5	
87	CSA7550001	1	布挡板 R	CROTH GUIDE R	
88	CS35326101	1	螺钉 M3.5	SCREW M3.5	
89	CS35315001	1	角块	OPENING SLIDE BLOCK	
90	CS35316001	1	角块支撑板	SLIDE BLOCK SUPPORT PLATE	
91	C060020416	2	螺钉 M2X4	SCREW BIND M2X4	
92	CS41341001	1	针板 LD13	NEEDLE PLATE, LD13	
93	CS06696004	2	螺钉 M3X6	SCREW, FLAT M3X6	
94	CS41337001	1	压脚 D13	WORK CLAMP, D13	
95	CS35236000	1	垫圈 3.2	WASHER, BENDING 3.2	
96	CS35235001	1	支架销	SUPPORT PIN, CLAMP	
97	C021300306	1	螺母 M3	NUT 3 M3	
98	CSA5560001	1	夹轴承受板	CLAMP SHAFT HOLDER	
99	C062400816	2	螺钉 M4X8	SCREW PAN M4X8	
100	CSA5674001	1	支点轴	CLAMP FULCRUM SHAFT	
101	C048060142	2	轴用挡圈 C6	RETAINING RING EXTERNAL C6	
102	CSA5671001	1	夹杆 L	CLAMP LEVER L	
103	C018501236	1	螺栓 M5X12	BOLT SOCKET M5X12	
104	CSA6743001	1	夹臂 L-J	CLAMP ARM L-J	
105	C014400536	2	螺钉 M4X5	SET SCREW SOCKET(CP) M4X5	
106	CSA7551001	1	布挡板 L	CROTH GUIDE L	
107	CS35326101	1	螺钉 M3.5	SCREW M3.5	



AA6 . 附属装置 / Attachment set

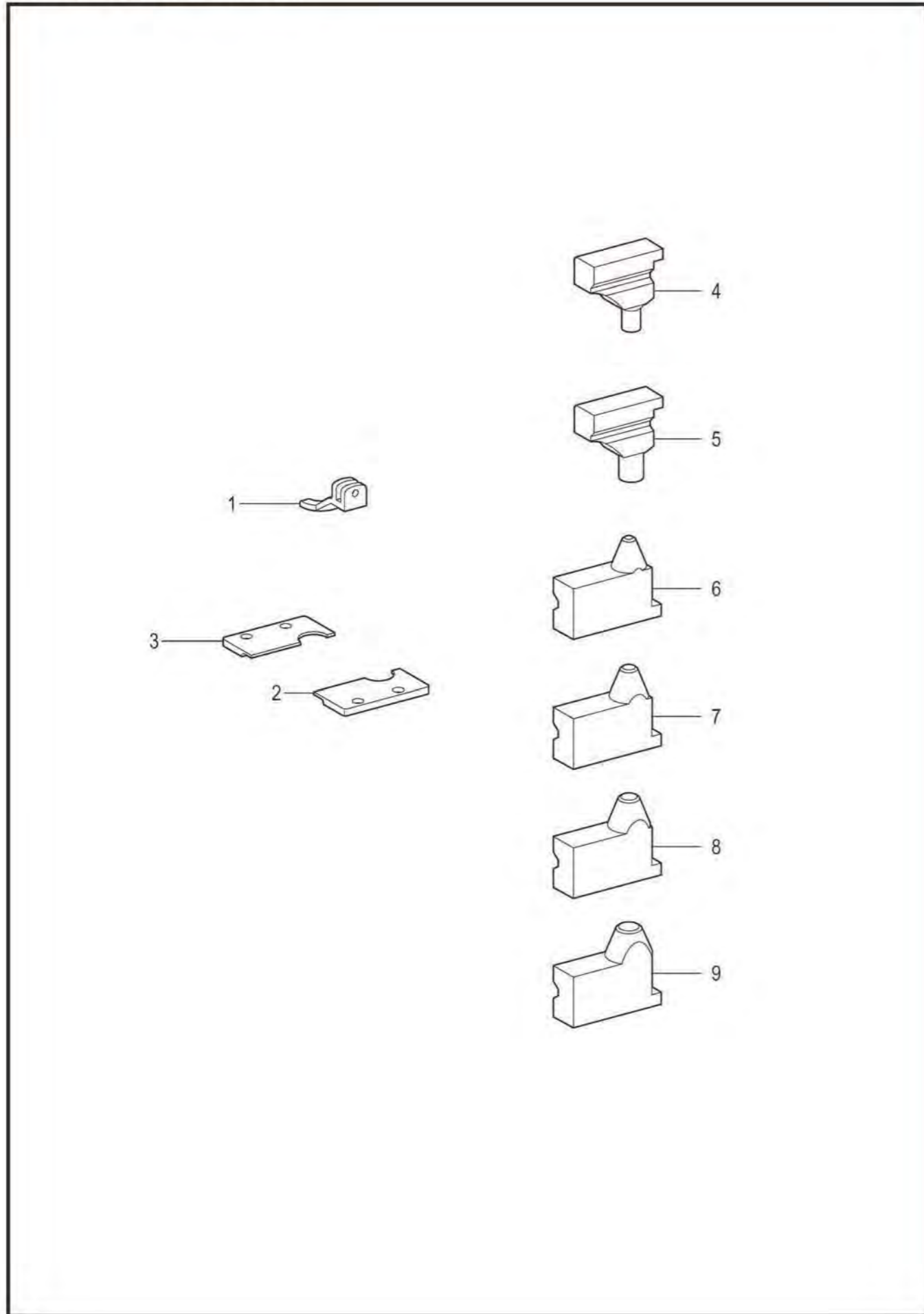

AA6. 附属装置 / Attachment set

参照号	零部件序号	数量	零部件名称	NAME OF PARTS	RM
1	CS41337001	1	<用于菊孔> 压脚 D13	<For circular stitch> WORK CLAMP, D13	
2	CS41340001	1	针板 RD13	NEEDLE PLATE, RD13	
3	CS41341001	1	针板 LD13	NEEDLE PLATE, LD13	
4	CS41344001	1	气锤 D3	CUTTING BLOCK, D3	
5	CS41345001	1	气锤 D5	CUTTING BLOCK, D5	
6	CS41346001	1	切刀 D2	KNIFE, D2	
7	CS41347001	1	切刀 D3	KNIFE, D3	
8	CS41348001	1	切刀 D4	KNIFE, D4	
9	CS41349001	1	切刀 D5	KNIFE, D5	



Z. 附件 / Accessories

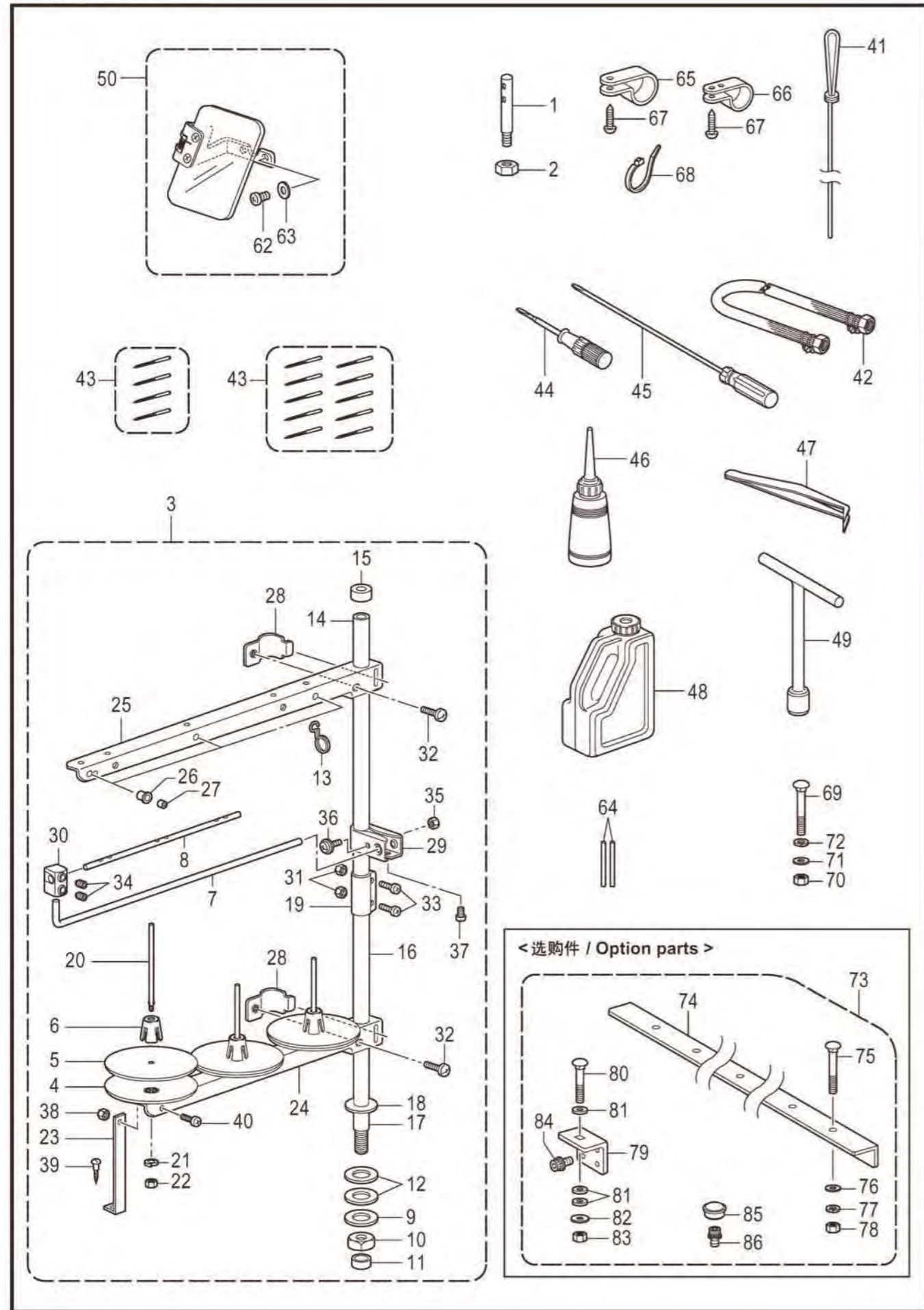

Z. 附件 / Accessories

参照号	零部件序号	数量	零部件名称	NAME OF PARTS	RM
1	CSA5568001	1	穿线杆	THREAD SPOOL PIN	
2	C021500216	1	六角螺母 M5	NUT 2 M5	
3	CS07558409	1	线架组件 3DRTHF	COTTON STAND ASSY 3DRTHF	
4	CS51283001	3	垫圈	SPOOL STAND BASE	
5	C150182000	3	线盘软垫	SPOOL MAT	
6	CS51282101	3	线轴缓冲架	SPOOL CUSHION	
7	CS04109001	1	过线杆支杆	THREAD GUIDE SUPPORT BAR	
8	C142997001	1	过线杆 3	THREAD GUIDE, 3	
9	C150206002	1	平垫圈 16	WASHER PLAIN 16	
10	CSA6629001	1	螺母 M16	NUT M16	
11	C150174000	1	线架支撑管套	COLUMN CAP	
12	CS01005000	2	橡皮垫圈	RUBBER WASHER	
13	CS02747101	1	弹簧	SPRING	
14	C150172003	1	线架支撑管	COLUMN PIPE	
15	C150174000	1	线架支撑管套	COLUMN CAP	
16	C156112003	1	线架撑管 D	COLUMN PIPE D	
17	C150207001	1	线架支撑管	COLUMN PIPE W/SCREW	
18	C150206000	1	平垫圈 16	WASHER PLAIN 16	
19	CSA6606001	1	线架管接头	COLUMN JOINT	
20	C150179002	3	线轴 B	SPOOL SHAFT B	
21	C028050244	3	弹簧垫圈 2-5	WASHER SPRING 2-5	
22	C021500104	3	螺母 M5	NUT 1 M5	
23	C150188009	1	下过线架支撑板 A	SPOOL HOLDER SUPPORT, A	
24	CSA6610001	1	过线架 3	SPOOL HOLDER 3	
25	CSA6610001	1	过线架 3	SPOOL HOLDER 3	
26	C150183000	3	过线管套	THREAD HANGER BASE	
27	C142990001	3	过线架上过线管	THREAD BUSH	
28	CSA6609001	2	过线架定位	SPOOL HOLDER SUPPORTER	
29	CSA6615001	1	线导向架	THREAD GUIDE HOLDER	
30	C138843001	1	连接器	JOINT	
31	C021500104	2	螺母 M5	NUT 1 M5	
32	C062061604	2	螺钉 M6X16	SCREW PAN M6X16	
33	C062501404	2	螺钉 M5X14	SCREW PAN M5X14	
34	C014060632	2	固定螺钉 M6X6	SET SCREW SOCKET (CP) M6X6	
35	C021500104	1	螺母 M5	NUT 1 M5	
36	CS37037001	1	螺钉 M5X32	SCREW PAN (S/P WASHER) M5X32	
37	C062061004	1	螺钉 M6X10	SCREW PAN M6X10	
38	C021500104	1	螺母 M5	NUT 1 M5	
39	C031452204	1	圆头木螺钉 M4.5X22	WOOD SCREW ROUND M4.5X22	
40	C062501004	1	螺钉 M5X10	SCREW PAN M5X10	
41	CSA7037001	1	穿线器	THREADER	
42	C149796001	1	像皮管带接头	AIR HOSE, W/CONNECTOR	
			<用于中国以外> <蓝狮牌机针 DO x 558> <用于-00>#100 机针组 S35133(10枚) <用于-01>#90 机针组 S35133(10枚) <用于-02>#110 机针组 S35133(10枚)	<Except for China> <Schmet DO x 558> <For -00>#100 NEEDLE 10PIECE ASSY, S35133 <For -01>#90 NEEDLE 10PIECE ASSY, S35133 <For -02>#110 NEEDLE 10PIECE ASSY, S35133	
43	CSA1741016	1	机针组 S35133(10枚) <用于-00>#100	NEEDLE 10PIECE ASSY, S35133	
43	CSA1741014	1	机针组 S35133(10枚) <用于-01>#90	NEEDLE 10PIECE ASSY, S35133	
43	CSA1741018	1	机针组 S35133(10枚) <用于-02>#110	NEEDLE 10PIECE ASSY, S35133	
			<用于中国> <风琴牌机针 DO x 558-NY2> <用于-00>#100 机针组 SA4857(4枚) <用于-01>#90 机针组 SA4857(4枚) <用于-02>#110 机针组 SA4857(4枚)	<For China> <Organ Needle DO x 558-NY2> <For -00>#100 NEEDLE 4PIECE ASSY, SA4857 <For -01>#90 NEEDLE 4PIECE ASSY, SA4857 <For -02>#110 NEEDLE 4PIECE ASSY, SA4857	
43	CSA4858016	1	机针组 SA4857(4枚) <用于-00>#100	NEEDLE 4PIECE ASSY, SA4857	
43	CSA4858014	1	机针组 SA4857(4枚) <用于-01>#90	NEEDLE 4PIECE ASSY, SA4857	
43	CSA4858018	1	机针组 SA4857(4枚) <用于-02>#110	NEEDLE 4PIECE ASSY, SA4857	



Z. 附件 / Accessories

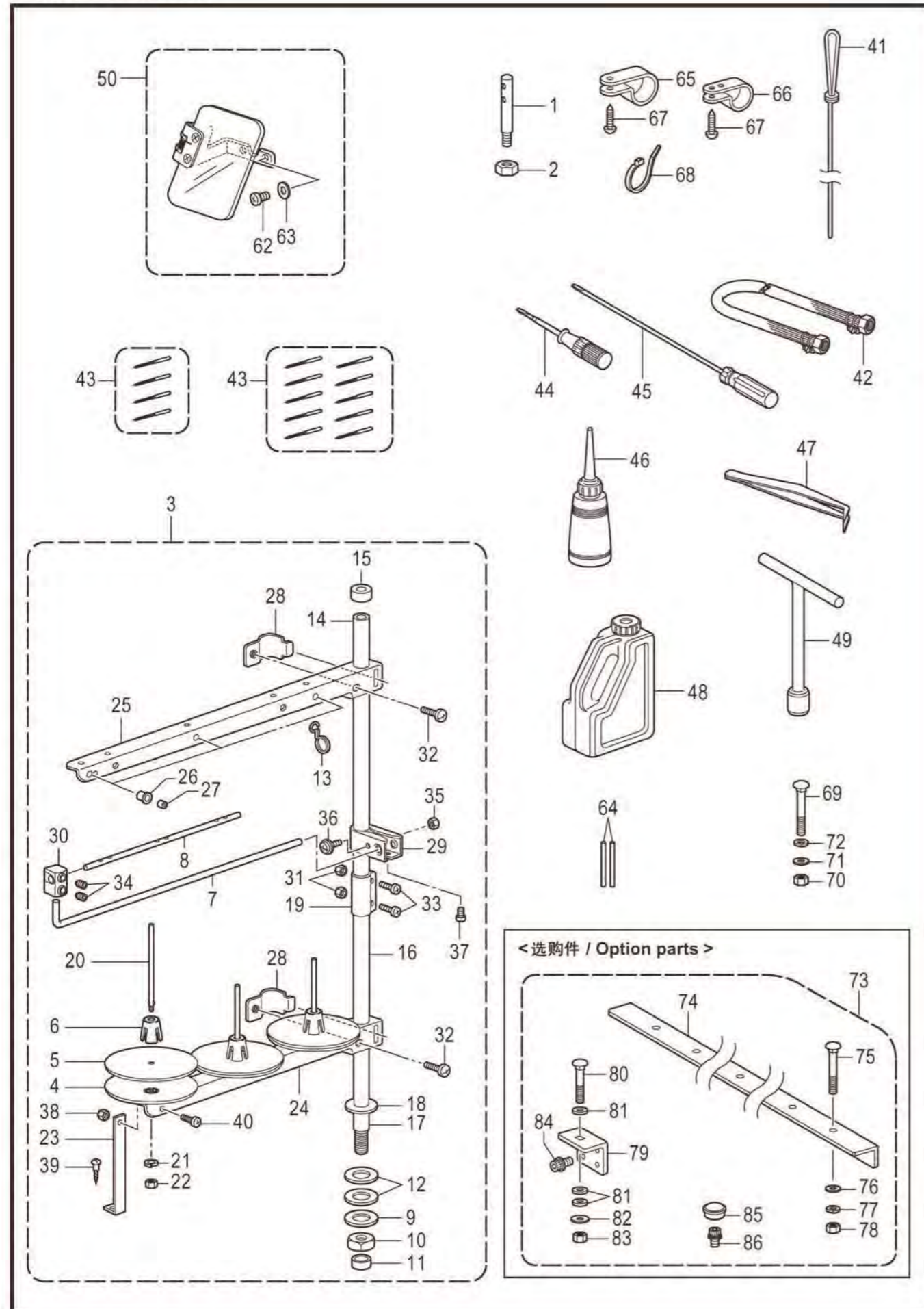

Z. 附件 / Accessories











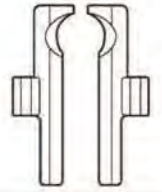
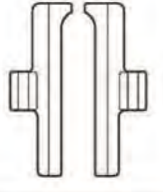
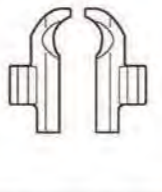
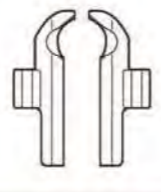
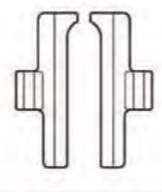

参照号	零部件序号	数量	零部件名称	NAME OF PARTS	RM
44	C 118837001	1	起子 3.4X70	SCREW-DRIVER, 3.4X70	
45	C 101572102	1	起子 5.5X190	SCREW-DRIVER 5.5X190	
46	C 114483002	1	油壶组件	OILER ASSY	
47	C 117466000	1	镊子	PINCETTE	
48	CS55663001	1	油罐组件	OIL TANK ASSY	
49	CSA3950001	1	套筒扳手	SOCKET WRENCH	
50	CSA4103001	1	护眼板组件 D	EYE GUARD SET, D	
62	C 062400616	2	螺钉 M4X6	SCREW PAN M4X6	
63	C 026040136	2	平垫圈 S4	WASHER PLAIN S 4	
64	CSA7038001	2	销 4	PIN 4	
65	C 158581000	1	电线夹 24N	CORD HOLDER, 24N	
66	CS11817000	1	线夹 NK-18N	CLAMP, NK-18N	
67	C 032461606	2	木螺钉 M4.5X16	WOOD SCREW ROUND 2 M4.5X16	
68	CS04557000	1	电线夹 PLT1M	BAND, PLT1M	
<用于脚踏板>					
69	C 133740006	3	螺栓 M6X70	BOLT SQUARE M6X70	
70	C 021060106	3	螺母 M6	NUT 1 M6	
71	C 025060236	3	平垫圈 M6	WASHER PLAIN M 6	
72	C 028060246	3	弹簧垫圈 2-6	WASHER SPRING 2-6	
<选购件>					
73	CSA7127001	1	半沈入复合件	SUBMERGE SET	
74	CSA7128001	2	L型补强板	ANGLE L	
75	C 133740006	10	螺栓 M6X70	BOLT SQUARE M6X70	
76	C 025060236	10	平垫圈 M6	WASHER PLAIN M 6	
77	C 028060246	10	弹簧垫圈 2-6	WASHER SPRING 2-6	
78	C 021060106	10	螺母 M6	NUT 1 M6	
79	CSA7129001	4	底板台支撑板	BED SUPPORT PLATE P	
80	C 119755001	4	螺栓 M6X60	BOLT, M6X60	
81	C 159458009	12	橡皮垫	RUBBER SHEET	
82	C 025060336	4	平垫圈 L6	WASHER PLAIN L 6	
83	C 021060106	4	螺母 M6	NUT 1 M6	
84	CS42445001	16	螺栓 M8X25	BOLT SOCKET (S/P WASHER)M8X25	
85	CSA2929001	4	橡皮塞 12.5	RUBBER CAP, 12.5	
86	CS55477001	3	螺栓(带垫圈) M6X16	BOLT SOCKET (S/P WASHER)M6X16	



Sp . 不同规格零部件一览表 / Different parts list

-00 规格时可以安装 10 - 50mm  
-01 规格时可以安装 10 - 42mm

10 to 50 mm are available for -00 specification.  
10 to 42 mm are available for -01 specification.

布压脚 / Work clamp					
(L)	CS37679-001	CS37677-101	CSA5245-101	CSA7086-001	CSA7537-001
(R)	CS37680-001	CS37678-101	CSA5244-101	CSA7091-001	CSA7536-001
(-00--01)	< 50mm >	< 50mm >	< 32mm >	< 42mm >	< 42mm >
					
	CS35455-201	CS39929-101	CS35197-101	CS39931-101	
	CS35454-201	CS39930-101	CS35198-101	CS39932-101	
< 10 - 18mm >	< 18 - 22mm >	< 22 - 26mm >	< 26 - 30mm >		
					
(-02)	CSA7087-001	CSA7090-001	CSA6742-001	CSA7088-001	CSA7089-001
	CSA7092-001	CSA7095-001	CSA6732-001	CSA7093-001	CSA7094-001
	< 14 - 22mm >	< 18 - 26mm >	< 22 - 30mm >	< 26 - 34mm >	< 34 - 42mm >
					
	CS43408-001	CS43410-001			
	CS43409-001	CS43411-001			
	L3W < 22 - 26mm >	L4W < 26 - 30mm >			
					
< 用于腰带压脚 / For waist belt presser >					

Sp . 不同规格零部件一览表 / Different parts list

-00 规格时 42mm 和 50mm 可以通用安装  
-01 规格时只能安装在 42mm

Both 42 mm and 50 mm are available for -00 specification.  
Only 42 mm is available for -01 specification.

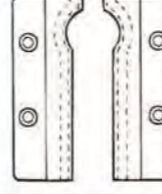
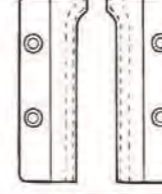
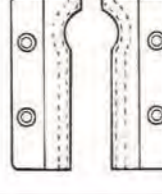
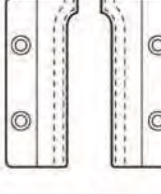
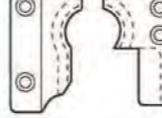
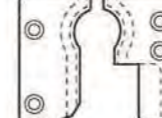
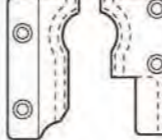
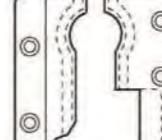
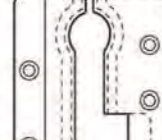
针板 / Needle plate				
(L)	CS37683-101(L-50)	CS37681-101(SL-50)	CSA5672-001(L-42)	CSA7534-001
(R)	CS37684-101(R-50)	CS37682-101(SR-50)	CSA5673-001(R-42)	CSA7535-001
(-00--01)	< 50mm >	< 50mm >	< 42mm >	< 42mm >
				
(L)	CSA7097-001	CSA7100-001		
(R)	CSA7102-001	CSA7105-001		
(-02)	< 14 - 22mm >	< 18 - 26mm >		
				
	CSA6741-001	CSA7098-001	CSA7099-001	
	CSA6731-001	CSA7103-001	CSA7104-001	
< 22 - 30mm >	< 26 - 34mm >	< 34 - 42mm >		
				

气锤 / Hammer

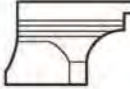
(-00--01)	尺寸 / Size (mm)	10	12	14	16	
	零部件序号 / Code	CS37211-001	CS37210-001	CS37209-001	CS37208-001	
	尺寸 / Size (mm)	18	20	22	24	
	零部件序号 / Code	CS37194-001	CS35092-001	CS37195-001	CS37196-001	
	尺寸 / Size (mm)	26	28	30	32	
	零部件序号 / Code	CS37197-001	CS37198-001	CS37199-001	CS37200-001	
	尺寸 / Size (mm)	34	36	38	42	
	零部件序号 / Code	CS37201-001	CS37202-001	CS35093-001	CSA7106-001	
尺寸 / Size (mm)	50					
零部件序号 / Code	CS35479-001					
(-02)	尺寸 / Size (mm)	S10	S12	S14	S16	
	零部件序号 / Code	CS37701-001	CS37702-001	CS37703-001	CS37704-001	
	尺寸 / Size (mm)	S18	S20	S22	S24	
	零部件序号 / Code	CS37705-001	CS37706-001	CS37707-001	CS37708-001	
	尺寸 / Size (mm)	S26	S28			
	零部件序号 / Code	CS37709-001	CS42053-001			

气锤：标准零部件 / Hammer : Standard parts

		装着零部件 / Preinstalled parts		附带零部件 / Accessory parts	
(-00,01)		22	CS37195-001	30	CS37199-001
	L1826	S20	CS37706-001	S24	CS37708-001
(-02)	L2230	S24	CS37708-001	S28	CS42053-001



Sp. 不同规格零部件一览表 / Different parts list

切刀 / Knife				
CS35438-101	CS35436-101	CS35481-101	CS35483-101	CS35409-101(S)
< 50mm >	< 50mm >	< 50mm >	< 50mm >	< 50mm >
CSA7107-001	CSA6806-001	CSA7108-001	CSA7109-001	CSA7110-001
< 42mm >	< 42mm >	< 42mm >	< 42mm >	< 42mm >
CSA7111-001(S)				
< 42mm >				

转盘板 / Throat plate

(-00--01)	CSA7546-001	CSA7065-001	CSA7567-001
	CS37752-001	CSA7568-001	
(-02)			

Wa. 警告标签 / Warning labels

警告标签 Warning labels	零部件名称 Name of parts	尺寸 Size(mm)	零部件序号 Code
	感电标签(6国) Label, elec. shock 6 lang	50 X 118	CJ04115-001
	操作注意标签(日/英) Label, caution Jpn / Eng	52 X 84	CSA0792-001
	操作注意标签(中/英) Label, caution Chn / Eng	52 X 84	CSA0793-001
	警告标记 Mark, injury	L=16 R=0.8	CS36924-001
	高温标志 Label, high temp	13 X 20	CJ03663-001
	接地标记 Label, grounding	φ 12	CS37060-001
	PE标记 Label, PE	7.5 X 12.5	CS37059-001



CODE	REF.NO	Page	CODE	REF.NO	Page	CODE	REF.NO	Page	CODE	REF.NO	Page
C004401003	A -48	2	C017400802	P1 -51	44	C018501636	H -53	28	C025060236	Z -71	100
	G -4	24		P2 -27	48		H -56	28		Z -76	100
	L -16	34	C017401415	P1 -47	44		X -17	72	C025060336	A -18	2
C008401204	G -70	26	C017401616	F1 -54	16	C018502536	G -34	24		Z -82	100
C012060636	E -5	14	C018061236	E -19	14	C021020106	Q1 -36	52	C026040136	G -24	24
	E -17	14		H -21	28		AA4 -61	86		G -59	24
	G -10	24	C018061636	D -19	12		AA5 -57	92		L -14	34
	G -13	24		G -45	24	C021060106	A -19	2		P2 -35	48
	G -26	24		G -66	26		D -10	12	C026040236	F1 -19	16
	G -30	24	C018084036	J -28	30		Z -70	100	C028040242	F1 -57	16
	G -39	24	C018260832	Q1 -26	52		Z -78	100	C028040246	A -46	2
	G -57	24		AA4 -51	86	C021300302	Z -83	100		P1 -52	44
	G -62	24		AA5 -47	92		F2 -29	20		P2 -28	48
C012061036	D -15	12	C018300836	L -58	36		F2 -47	20	C028050244	Z -21	98
	H -31	28	C018301236	D -26	12		F3 -23	22	C028060246	Z -72	100
	H -44	28	C018301436	L -10	34		F3 -47	22		Z -77	100
	J -23	30	C018400636	B -61	8	C021300306	L -38	34	C031452204	Z -39	98
C012500536	B -56	6		L -2	34		AA1 -18	78	C031553202	U1 -39	64
	D -22	12		N -21	40		AA1 -72	78		U2 -25	66
	F1 -64	16		N -31	40		AA3 -7	84	C032461606	Z -67	100
	H -26	28		N -97	42		AA3 -13	84	C047301042	P2 -23	48
	K -7	32		R -4	56		AA4 -14	86	C047502242	A 13	2
	L -35	34	C018400836	F1 -94	18		AA4 -83	88	C048025346	P3 -22	50
	M -16	38		G -42	24		AA5 -78	94		AA2 -33	82
	P1 -43	44		N -53	40	C021350106	AA5 -97	94	C048030342	F1 -25	16
	U2 -32	66		P2 -34	48		Q1 -13	52		F1 -46	16
C014060632	K -21	32		P2 -36	48		Q2 -20	54		F1 -112	18
	Z -34	98		P3 -18	50		AA1 -55	78		AA2 -12	82
C014060636	B -59	8		P3 -31	50		AA4 -38	86	C048050142	F1 -27	16
C014060836	A -31	2		V -8	68		AA5 -34	92		F1 -99	18
	A -33	2		V -17	68	C021400202	F1 -55	16		AA2 -10	82
	A -37	2		AA2 -42	82		Q2 -8	54		AA4 -122	88
	A -39	2	C018401036	B -7	6		Y -9	74		AA5 -61	92
	H -29	28		B -9	6	C021400206	A -44	2	C048050342	F1 -8	16
	H -34	28		F3 -37	22		H -20	28		F1 -15	16
	H -40	28		H -7	28		P1 -19	44	C048060142	F1 -110	18
	H -46	28		P1 -18	44		AA1 -43	78		F2 -33	20
	L -34	34		P1 -23	44	C021400306	P1 -48	44		F2 -51	20
	U1 -6	64		Q1 -8	52		P3 -6	50		F3 -27	22
C014300332	P3 -27	50		AA1 -32	78		Q1 -46	52		F3 -35	22
	AA2 -38	82		AA4 -33	86		Q2 -16	54		F3 -51	22
C014300832	L -73	36		AA5 -29	92		AA1 -51	78		M -15	38
C014400532	B -38	6	C018401236	H -14	28		AA4 -71	88		P1 -26	44
	F1 -48	16	C018401436	G -23	24		AA4 -114	88		AA1 -22	78
	F1 -100	18		G -58	24		AA5 -66	94		AA1 -30	78
	F2 -37	20	C018401636	E -22	14	C021400316	L -79	36		AA1 -76	80
	F2 -55	20		G -14	24	C021500104	Z -22	98		AA4 -18	86
	F3 -31	22	C018402036	B -27	6		Z -31	98		AA4 -87	88
	F3 -55	22	C018501236	F1 -30	16		Z -35	98		AA5 -82	94
C014400536	H -48	28		F2 -35	20		Z -38	98		AA5 -101	94
	AA1 -26	78		F2 -53	20	C021500106	Z -2	98	C048060342	G -68	26
	AA1 -80	80		F3 -29	22	C021500216	P1 -62	44	C048080142	A -24	2
	AA2 -14	82		F3 -53	22	C025030136	L -59	36		A -26	2
	AA4 -22	86		R -11	56	C025030236	L -66	36		G -35	24
	AA4 -91	88		AA1 -24	78		AA2 -25	82		P2 -9	48
	AA4 -123	88		AA1 -78	80		AA4 -101	88	C048100142	E -11	14
	AA5 -86	94		AA4 -20	86	C025040136	G -15	24		E -28	14
	AA5 -105	94		AA4 -89	88	C025040236	M -18	38	C048150142	C -28	10
C014400632	X -3	72		AA5 -84	94		P1 -53	44	C048160242	G -31	24
C014500632	X -16	72		AA5 -103	94		P2 -29	48	C048200142	J -27	30
C014500836	H -39	28	C018501436	G -48	24		V -18	68	C048220242	J -20	30
	K -2	32	C018501636	G -8	24	C025060236	F1 -109	18		E -9	14
	M -2	38		G -44	24		P1 -27	44		E -26	14

CODE	REF.NO	Page	CODE	REF.NO	Page	CODE	REF.NO	Page	CODE	REF.NO	Page
C048280242	G -64	26	C062300416	H -55	28	C062500816	P1 -60	44	C107155001	N -81	42
C048320242	E -15	14		P3 -9	50		P1 -71	46	C109763002	F1 -7	16
C048520242	C -20	10		Q1 -47	52	C062501004	Z -40	98		F1 -14	16
C052400606	F1 -76	18		Q2 -22	54	C062501202	F1 -32	16	C112753001	N -74	42
C060020416	F2 -23	20		AA1 -57	78	C062501216	A -3	2	C114483002	Z -46	100
	F2 -42	20		AA4 -72	88		A -6	2	C114486002	A -28	2
	F3 -19	22		AA4 -117	88		P1 -69	46	C115947101	A -17	2
	F3 -43	22		AA5 -67	94	C062501404	Z -33	98	C117466000	Z -47	100
	AA1 -14	78	C062300508	L -65	36	C070688850	G -37	24	C118837001	Z -44	100
	AA1 -68	78		AA2 -24	82	C081003870	P3 -23	50	C119755001	Z -80	100
	AA4 -8	86		AA4 -100	88		AA2 -34	82	C133740006	Z -69	100
	AA4 -77	88	C062300512	Q1 -29	52	C081050870	H -22	28		Z -75	100
	AA5 -74	94		AA4 -54	86	C0A4261006	X -8	72	C137191051	Q1 -3	52
	AA5 -91	94		AA5 -50	92	C0A4300805	L -83	36		Q2 -14	54
C060300416	L -41	34	C062300616	B -42	6	C0A4300806	X -6	72		AA1 -49	78
	AA4 -104	88	C062300816	V -2	68		X -14	72		AA4 -28	86
C060300616	Y -11	74		V -39	68	C0A4400806	J -39	30		AA5 -24	92
C060300816	K -13	32	C062301016	F1 -21	16		N -10	40	C138843001	Z -30	98
	K -17	32		L -37	34		N -15	40	C140553102	B -20	6
	L -82	36	C062351615	L -6	34		N -17	40	C141514002	B -18	6
	L -84	36	C062400616	N -39	40		N -19	40	C141542001	Q1 -20	52
	AA2 -19	82		Z -62	100		N -23	40		Q2 -11	54
C060400516	L -69	36	C062400816	A -41	2		N -37	40		AA1 -46	78
	M -10	38		F1 -20	16		N -43	40		AA4 -45	86
	N -86	42		F1 -56	16		N -70	42		AA5 -41	92
	P1 -14	44		F1 -102	18		N -76	42	C142990001	Z -27	98
	P2 -6	48		F1 -107	18		P1 -64	44	C142997001	Z -8	98
	P2 -13	48		F2 -31	20		P1 -66	44	C144103009	P1 -38	44
	Q1 -41	52		F2 -49	20		U1 -16	64	C144504001	P1 -56	44
	Q2 -29	54		F3 -25	22		U1 -22	64	C145446001	P1 -36	44
	AA1 -64	78		F3 -49	22		V -4	68		P2 -17	48
	AA4 -66	88		H -60	28		V -20	68		AA2 -36	82
	AA5 -61	92		J -37	30		V -29	68	C145446002	P3 -25	50
C060400816	N -94	42		M -17	38		V -32	68	C145465001	B -4	6
	Y -13	74		N -11	40		V -34	68	C146124001	Y -10	74
C060401016	L -24	34		P1 -73	46		V -36	68	C146202000	N -14	40
C060401216	A -12	2		P2 -11	48		Y -17	74	C149287000	N -69	42
C060401416	L -13	34		P3 -13	50	C0A4401006	X -12	72	C149547000	N -18	40
C060630312	Q1 -45	52		P3 -29	50	C0A4401206	U1 -24	64		P1 -63	44
	AA4 -70	88		P3 -34	50		U1 -26	64		V -33	68
	AA5 -65	94		V -22	68	C0A4401606	A -8	2	C149796001	Z -42	98
C061300416	Q1 -24	52		V -24	68	C0A4403506	U2 -10	66	C150172003	Z -14	98
	AA4 -49	86		V -40	68	C0A4404006	U2 -23	66	C150174000	Z -11	98
	AA5 -45	92		X -25	72	C0A5300606	X -10	72		Z -15	98
C062020416	Q1 -35	52		AA1 -20	78	C0A5302005	V -7	68	C150179002	Z -20	98
	AA4 -60	86		AA1 -74	80	C0A5401006	U2 -28	66	C150182000	Z -5	98
	AA5 -56	92		AA2 -8	82	C0B0452006	W -6	70	C150183000	Z -26	98
C062061004	Z -37	98		AA2 -40	82	C101572102	Z -45	100	C150188009	Z -23	98
C062061604	Z -32	98		AA4 -16	86	C102630001	F1 -4	16	C150206000	Z -18	98
C062260406	P3 -24	50		AA4 -85	88		F1 -11	16	C150206002	Z -9	98
	AA1 -56	78		AA4 -125	90	C102707002	P1 -49	44	C150207001	Z -17	98
	AA2 -35	82		AA5 -80	94	C104336003	Q1 -43	52	C150756000	A -56	2
	AA4 -39	86		AA5 -99	94		AA4 -68	88		A -57	2
	AA5 -35	92	C062401016	C -32	10		AA5 -63	92		A -58	2
C062260516	Q1 -6	52	C062402016	L -77	36	C104450101	N -60	40		A -59	2
	Q1 -14	52	C062500816	A -29	2	C104821001	A -55	2	C152873001	P1 -42	44
	Q2 -21	54		J -30	30		P1 -67	46	C152904001	Q1 -42	52
C062260612	Q2 -24	54		N -72	42	C104833001	A -50	2		AA4 -67	88
	AA1 -59	78		P1 -11	44		A -51	2		AA5 -62	92



CODE	REF.NO	Page	CODE	REF.NO	Page	CODE	REF.NO	Page	CODE	REF.NO	Page
C153274001	U2 - 8	66	CS00480000	U1 - 15	64	CS21728001	A - 15	2	CS34896001	AA5 - 44	92
C153787001	Q2 - 30	54	CS01005000	Z - 12	98	CS23651001	C - 4	10	CS34898001	Q1 - 19	52
	AA1 - 38	78	CS01694001	Q1 - 22	52		C - 9	10		AA4 - 44	86
C154465001	A - 27	2		AA4 - 47	86		C - 11	10		AA5 - 40	92
C154562101	F1 - 57	44		AA5 - 43	92		C - 14	10	CS34899001	Q1 - 18	52
	F2 - 19	48	CS02460001	F1 - 59	16		C - 17	10		AA4 - 43	86
C154599000	F1 - 46	44		F1 - 62	16		C - 19	10		AA5 - 39	92
	F2 - 32	48	CS02657101	N - 99	42		C - 24	10	CS34900001	Q1 - 16	52
C155510001	F1 - 58	44	CS02699001	Y - 6	74		C - 26	10		AA4 - 41	86
C155559001	D - 12	12	CS02747101	Z - 13	98		C - 30	10		AA5 - 37	92
	F2 - 31	48	CS04109001	Z - 7	98		J - 6	30	CS34901001	Q1 - 15	52
C156112003	Z - 16	98	CS04159000	P2 - 33	48		J - 10	30		AA4 - 40	86
C156482000	D - 23	12		V - 16	68		J - 14	30		AA5 - 36	92
C158581000	Z - 65	100	CS04567000	F1 - 73	18		X - 23	72	CS34902001	Q1 - 12	52
C158722001	F3 7	50		P3 30	50	CS25235001	C 5	10		Q2 19	54
	AA4 - 115	88		Y - 12	74	CS25279101	M - 20	38		AA1 - 54	78
C158827009	A - 14	2		AA2 - 41	82	CS25328001	B - 53	6		AA4 - 37	86
C158882001	A - 60	2		Z - 68	100		N - 54	40		AA5 - 33	92
C159221101	F1 - 39	44	CS05356000	F3 - 38	22		N - 73	42	CS34903001	Q1 - 10	52
C159458009	A - 16	2		P1 - 29	44	CS29700000	N - 46	40		AA4 - 35	86
	Z - 81	100		AA1 - 33	78		N - 49	40		AA5 - 31	92
C159805001	F1 - 37	44	CS06896004	B - 36	6	CS32263001	A - 52	2	CS34905101	Q1 - 7	52
	F2 - 18	48		F1 - 52	16		A - 53	2		AA4 - 32	86
C228475000	B - 52	6		F2 - 19	20		A - 54	2		AA5 - 28	92
	J - 36	30		F2 - 25	20	CS34569000	U1 - 18	64	CS34906100	Q1 - 5	52
	M - 9	38		F3 - 20	22	CS34883001	Q1 - 11	52		AA4 - 30	86
	N - 92	42		F3 - 44	22		AA4 - 36	86		AA5 - 26	92
	P1 - 68	46		AA1 - 15	78		AA5 - 32	92	CS34913001	F1 - 93	18
	U2 - 31	66		AA1 - 69	78	CS34884000	Q1 - 44	52	CS34914101	F1 - 92	18
	V - 41	68		AA4 - 10	86		AA4 - 69	88	CS34922101	Y - 7	74
	Y - 18	74		AA4 - 79	88		AA5 - 64	92	CS34966001	Y - 8	74
C340400001	V - 25	68		AA5 - 75	94	CS34886001	Q1 - 39	52	CS34968000	F1 - 22	16
C3A6001001	G - 28	24		AA5 - 93	94		AA4 - 64	88	CS34969001	F1 - 24	16
C525567000	U1 - 21	64	CS07558409	Z - 3	98		AA5 - 59	92	CS34970001	F1 - 83	18
C525664000	V - 19	68	CS10243000	J - 38	30	CS34887001	Q1 - 38	52		F1 - 87	18
C530138001	G - 33	24		N - 16	40		AA4 - 63	88	CS35001000	N - 4	40
C542515001	Q1 - 37	52		N - 22	40		AA5 - 71	94		N - 30	40
	AA4 - 62	88		N - 36	40	CS34888101	Q1 - 33	52	CS35014001	L - 27	34
	AA5 - 58	92		V - 3	68		AA4 - 58	86	CS35018001	L - 26	34
C552907000	N - 42	40		V - 35	68		AA5 - 54	92	CS35019001	L - 28	34
C552908000	U1 - 23	64		Y - 16	74	CS34889101	Q1 - 30	52	CS35029001	L - 42	34
C554482000	U1 25	64	CS11426000	F1 - 86	18		AA4 55	86		AA4 105	88
C625010000	V - 31	68		P1 - 8	44		AA5 - 51	92	CS35032101	L - 49	34
CJ03663001	E - 2	14	CS11817000	Z - 66	100	CS34890001	Q1 - 31	52		L - 52	34
	G - 67	26	CS12004000	F1 - 58	16		AA4 - 56	86	CS35033001	L - 51	34
	X - 19	72		F1 - 61	16		AA5 - 52	92	CS35034001	L - 50	34
	Wa	104		G - 49	24	CS34891101	Q1 - 32	52	CS35035101	L - 55	36
CJ03955001	X - 2	72	CS12053000	R - 6	56		AA4 - 57	86	CS35036101	L - 56	36
CJ03956001	X - 4	72	CS12104000	F1 - 72	18		AA5 - 53	92	CS35091101	H - 6	28
CJ03957001	X - 5	72	CS12150000	F1 - 90	18	CS34892001	Q1 - 34	52	CS35092001	Sp	102
CJ03958001	X - 7	72		F1 - 104	18		AA4 - 59	86	CS35093001	Sp	102
CJ03974001	W - 7	70		AA2 - 5	82		AA5 - 55	92	CS35097101	H - 52	28
CJ04115001	S1 - 12	58	CS12718000	K - 20	32	CS34893001	Q1 - 28	52	CS35098000	H - 54	28
	Wa	104	CS13955000	F1 - 36	16		AA4 - 53	86	CS35113001	B - 32	6
CJ04146001	W 8	70		F1 42	16		AA5 49	92	CS35118101	B 19	6
CJ04230001	X - 11	72	CS14159000	U2 - 6	66	CS34894001	Q1 - 27	52	CS35133014	R - 21	6
CJ04303001	X - 15	72	CS20681000	P1 - 41	44		AA4 - 52	86	CS35133016	B - 21	6
CJ04388001	X - 13	72	CS20682102	P1 - 40	44		AA5 - 48	92	CS35133018	B - 21	6
CS00470000	U2 - 27	66	CS20696001	P3 - 12	50	CS34895001	Q1 - 25	52	CS35136001	B - 40	6
CS00480000	N - 9	40		P3 - 33	50		AA4 - 50	86	CS35137001	B - 39	6
	N - 41	40	CS20698221	P1 - 55	44		AA5 - 46	92	CS35183000	G - 16	24
	N - 75	42	CS21716001	Q2 - 26	54	CS34896001	Q1 - 23	52	CS35197101	Sp	101
	P1 - 65	44		AA1 - 61	78		AA4 - 48	86	CS35198101	Sp	101

CODE	REF.NO	Page	CODE	REF.NO	Page	CODE	REF.NO	Page	CODE	REF.NO	Page
CS35218101	A - 23	2	CS35326101	AA1 - 82	80	CS37210001	Sp	102	CS41337001	AA5 - 94	94
CS35221101	A - 43	2		AA4 - 24	86	CS37211001	Sp	102		AA6 - 1	96
	A - 66	4		AA4 - 93	88	CS37654000	Q2 - 9	54	CS41340001	AA5 - 5	92
CS35235001	F2 - 28	20		AA5 - 11	92		AA1 - 44	78		AA5 - 20	92
	F2 - 46	20		AA5 - 14	92	CS37655101	Q2 - 10	54		AA6 - 2	96
	F3 - 22	22		AA5 - 88	94		AA1 - 45	78	CS41341001	AA5 - 92	94
	F3 - 46	22		AA5 - 107	94	CS37660101	Q2 - 7	54		AA6 - 3	96
	AA1 - 17	78	CS35327001	F1 - 53	16		AA1 - 42	78	CS41344001	AA6 - 4	96
	AA1 - 71	78	CS35328001	F1 - 23	16	CS37677101	Sp	101	CS41345001	AA6 - 5	96
	AA3 - 5	84	CS35329001	F2 - 20	20	CS37678101	Sp	101	CS41346001	AA6 - 6	96
	AA3 - 11	84		AA4 - 94	88	CS37679001	Sp	101	CS41347001	AA6 - 7	96
	AA4 - 13	86	CS35330001	F2 - 15	20	CS37680001	Sp	101	CS41348001	AA6 - 8	96
	AA4 - 82	88		AA4 - 25	86	CS37681101	Sp	102	CS41349001	AA6 - 9	96
	AA5 - 77	94	CS35332001	B - 10	6	CS37682101	Sp	102	CS42053001	AA1 - 10	76
	AA5 - 96	94		D - 25	12	CS37683101	Sp	102		Sp	102
CS35236000	F2 - 27	20	CS35350000	F1 - 34	16	CS37684101	Sp	102	CS42445001	Z - 84	100
	F2 - 45	20		F1 - 40	16	CS37701001	Sp	102	CS42838301	Y - 19	74
	F3 - 21	22	CS35351001	F1 - 106	18	CS37702001	Sp	102	CS43408001	AA3 - 3	84
	F3 - 45	22		AA2 - 7	82	CS37703001	Sp	102		Sp	101
	AA1 - 16	78	CS35360000	U1 - 2	64	CS37704001	AA1 - 9	76	CS43409001	AA3 - 9	84
	AA1 - 70	78	CS35409101	Sp	103		Sp	102		Sp	101
	AA3 6	84	CS35410001	L 45	34	CS37705001	Sp	102	CS43410001	AA3 - 3	84
	AA3 - 12	84	CS35412101	L - 47	34	CS37706001	AA1 - 9	76		Sp	101
	AA4 - 12	86	CS35413101	L - 48	34		AA1 - 10	76	CS43411001	AA3 - 9	84
	AA4 - 81	88	CS35426100	U1 - 3	64		Sp	102		Sp	101
	AA5 - 76	94	CS35429101	F1 - 17	16	CS37707001	Sp	102	CS47270001	J - 7	30
	AA5 - 95	94	CS35436101	Sp	103	CS37708001	AA1 - 9	76	CS47932001	L - 54	34
CS35239101	F1 - 28	16	CS35438101	Sp	103		AA1 - 10	76		AA2 - 18	82
CS35240001	F1 - 29	16	CS35454201	Sp	101		Sp	102	CS49078001	L - 87	36
CS35251101	D - 13	12	CS35455201	Sp	101	CS37709001	Sp	102	CS49079001	L - 89	36
CS35252001	D - 17	12	CS35456101	F1 - 49	16	CS37723101	L - 43	34	CS49484000	S1 - 8	58
CS35284101	E - 7	14	CS35457001	F1 - 38	16		AA2 - 20	82	CS49992000	N - 40	40
CS35304001	F1 - 47	16	CS35458001	F1 - 44	16	CS37724001	L - 53	34	CS50168001	J - 21	30
CS35305001	F1 - 45	16	CS35472101	L - 88	36		AA2 - 16	82	CS51020000	N - 35	40
CS35315001	F2 - 21	20	CS35479001	Sp	102	CS37725001	L - 85	36		N - 102	42
	F2 - 40	20	CS35481101	Sp	103		AA2 - 17	82	CS51282101	Z - 6	98
	F3 - 17	22	CS35483101	Sp	103	CS37752001	L - 70	36	CS51283001	Z - 4	98
	F3 - 41	22	CS36260000	Y - 21	74		AA2 - 27	82	CS52431000	P2 - 22	48
	AA1 - 12	78	CS36345000	F1 - 79	18		Sp	103	CS52832000	L - 19	34
	AA1 - 66	78	CS36924001	A - 70	4	CS37858000	Q1 - 9	52	CS53488000	F1 - 35	16
	AA4 - 6	86		Wa	104		Q2 - 27	54		F1 - 41	16
	AA4 - 75	88	CS37037001	Z - 36	98		AA1 - 62	78	CS53982000	U2 - 3	66
	AA5 - 72	94	CS37059001	S1 - 10	58		AA4 - 34	86	CS55476001	G - 52	24
	AA5 - 89	94		Wa	104		AA5 - 30	92	CS55477001	A - 22	2
CS35316001	F2 - 22	20	CS37060001	A - 71	4	CS38170001	Y - 20	74		Z - 86	100
	F2 - 41	20		S1 - 11	58	CS38174000	Y - 22	74	CS55481001	F - 12	14
	F3 - 18	22		Wa	104	CS38175101	Y - 23	74		E - 29	14
	F3 - 42	22	CS371940								



CODE	REF NO	Page	CODE	REF NO	Page	CODE	REF NO	Page	CODE	REF NO	Page
CSA1741014	Z -43	98	CSA5552001	E -27	14	CSA5672001	F2 -43	20	CSA5811001	A -62	2
CSA1741016	Z -43	98	CSA5557001	F1 -5	16		AA4 -78	88	CSA5819001	A -63	4
CSA1741018	Z -43	98		F1 -12	16		Sp	102	CSA5820001	A -64	4
CSA1828001	F1 -82	18	CSA5558001	F1 -37	16	CSA5673001	F2 -24	20	CSA5821001	A -65	4
CSA2929001	Z -85	100		F1 -43	16		AA4 -9	86	CSA5830001	B -22	6
CSA3040001	N -57	40	CSA5560001	F2 -30	20		Sp	102	CSA5833001	B -26	6
CSA3060001	N -58	40		F2 -48	20	CSA5674001	F2 -32	20	CSA5834001	B -28	6
CSA3227001	P2 -20	48		F3 -24	22		F2 -50	20	CSA5835001	B -29	6
CSA3345001	P1 -45	44		F3 -48	22		F3 -50	22	CSA5837001	B -34	6
CSA3581101	S1 -13	58		AA1 -19	78		AA1 -75	80	CSA5842001	B -57	6
CSA3720101	S1 -2	58		AA1 -73	78		AA4 -17	86	CSA5843001	B -50	6
CSA3722001	S1 -7	58		AA4 -15	86		AA4 -86	88	CSA5849001	B -51	6
CSA3739501	S1 -5	58		AA4 -84	88		AA5 -81	94	CSA5850001	B -54	6
CSA3744001	S1 -6	58		AA5 -79	94		AA5 -100	94	CSA5865001	B -55	6
CSA3755201	S2 1	60		AA5 98	94	CSA5675001	F1 50	16	CSA5880001	B 58	8
CSA3762001	S2 -6	60	CSA5561001	F1 -96	18	CSA5676001	F1 -51	16	CSA5889001	R -60	8
CSA3765001	S2 -2	60	CSA5562001	G -17	24	CSA5677001	F1 -2	16	CSA5890001	C -1	10
CSA3766001	S2 -3	60		G -50	24	CSA5678001	F1 -9	16	CSA5893001	C -2	10
CSA3767001	S2 -4	60	CSA5563001	H -28	28	CSA5679001	F1 -89	18	CSA5897001	C -6	10
CSA3768001	S2 -5	60		H -38	28	CSA5680001	F1 -95	18	CSA5907001	B -37	6
CSA3769001	S2 -7	60		H -41	28	CSA5681001	F1 -65	18	CSA5908001	B -41	6
CSA3770001	S2 -8	60	CSA5564001	C -13	10	CSA5682001	F1 -66	18	CSA5919001	B -43	6
CSA3771001	S2 -9	60		C -16	10	CSA5683001	F1 -67	18	CSA5920001	B -44	6
CSA3784001	Y -25	74		J -9	30	CSA5684001	F1 -68	18	CSA5923001	B -46	6
CSA3789101	T -11	62	CSA5565001	K -11	32	CSA5688101	F1 -74	18	CSA5936001	B -1	6
CSA3794001	S2 -10	60		M -6	38	CSA5690001	F1 -1	16	CSA6364001	S1 -1	58
CSA3795001	S2 -11	60	CSA5566001	N -79	42	CSA5691001	F1 -63	16	CSA6517001	C -54	24
CSA3796001	S1 -14	58	CSA5567001	N -78	42	CSA5692001	F1 -60	16	CSA6518001	G -55	24
CSA3806001	S1 -9	58		N -80	42	CSA5693001	Q1 -4	52	CSA6521001	G -21	24
CSA3808101	S1 -3	58	CSA5568001	P1 -61	44		Q2 -15	54	CSA6522001	G -22	24
CSA3809001	T -8	62		Z -1	98		AA1 -50	78	CSA6525001	U2 -14	66
CSA3812001	T -7	62	CSA5570001	B -2	6		AA4 -29	86	CSA6526101	U2 -26	66
CSA3813001	T -1	62		J -19	30		AA5 -25	92	CSA6527001	F1 -91	18
CSA3816001	T -6	62	CSA5571001	C -3	10	CSA5696001	V -6	68	CSA6530001	V -1	68
CSA3819001	T -3	62		J -5	30	CSA5729001	V -10	68	CSA6531101	V -26	68
CSA3822001	T -2	62		L -4	34	CSA5730001	V -11	68	CSA6532001	V -42	68
CSA3825001	T -4	62	CSA5572001	C -8	10	CSA5731001	V -12	68	CSA6533001	V -14	68
CSA3827001	T -10	62		J -26	30	CSA5732001	V -13	68	CSA6535001	V -43	68
CSA3828001	T -14	62	CSA5573001	C -12	10	CSA5733001	V -21	68	CSA6536001	V -44	68
CSA3838009	T -13	62		J -8	30	CSA5734101	V -23	68	CSA6537001	P3 -21	50
CSA3950001	Z -49	100	CSA5574001	E -8	14	CSA5737001	V -28	68		AA2 -32	82
CSA4103001	Z -50	100		E 25	14	CSA5738001	V 30	68	CSA6538001	P1 -50	44
CSA4197001	G -56	24	CSA5576001	F2 -36	20	CSA5740001	V -37	68	CSA6539001	P2 -26	48
CSA4510001	I -12	62		AA4 -21	86	CSA5741001	V -38	68	CSA6542001	E -1	14
CSA4629001	C -29	10	CSA5577001	F2 -54	20	CSA5746001	A -1	2	CSA6546001	W -5	70
CSA4857014	B -21	6		AA4 -90	88	CSA5747001	A -2	2	CSA6547001	W -1	70
CSA4857016	B -21	6	CSA5578001	F1 -13	16	CSA5749001	A -4	2	CSA6550001	W -2	70
CSA4857018	B -21	6	CSA5579001	F1 -6	16	CSA5750001	A -5	2	CSA6554001	S1 -4	58
CSA4858014	Z -43	98	CSA5582001	F1 -31	16	CSA5751001	A -7	2	CSA6567101	Y -1	74
CSA4858016	Z -43	98	CSA5583001	F1 -18	16	CSA5752201	A -9	2	CSA6573001	U1 -36	64
CSA4858018	Z -43	98	CSA5584001	F1 -26	16	CSA5753001	A -10	2	CSA6606001	Z -19	98
CSA5148001	W -3	70		G -69	26	CSA5754001	A -20	2	CSA6609001	Z -28	98
CSA5158101	C -33	10		AA4 -128	90	CSA5763001	A -21	2	CSA6610001	Z -24	98
CSA5244101	Sp	101	CSA5585001	F2 -34	20	CSA5764001	A -25	2		Z -25	98
CSA5245101	Sp	101		F3 28	22	CSA5765101	A 30	2	CSA6615001	Z 29	98
CSA5283001	U2 -7	66		AA1 -23	78	CSA5766001	A -32	2	CSA6618001	V -5	68
CSA5360001	W -4	70		AA4 -19	86	CSA5791101	A -34	2	CSA6629001	Z -10	98
CSA5433101	V -49	68		AA5 -83	94	CSA5792001	A -35	2	CSA6636001	V -46	68
CSA5434001	V -45	68	CSA5671001	F2 -52	20	CSA5802001	A -36	2	CSA6652001	B -3	6
CSA5435001	F1 -75	18		F3 -52	22	CSA5803001	A -40	2	CSA6653001	B -5	6
CSA54549001	C -18	10		AA1 -77	80	CSA5804001	A -42	2	CSA6654101	B -6	6
	X -22	72		AA4 -88	88	CSA5805001	A -47	2	CSA6655001	B -8	6
CSA5552001	E -10	14		AA5 -102	94	CSA5810001	A -61	2	CSA6656001	B -12	6

CODE	REF NO	Page	CODE	REF NO	Page	CODE	REF NO	Page	CODE	REF NO	Page
CSA6657001	B -13	6	CSA6737001	F3 -39	22	CSA6800001	H -47	28	CSA6879001	L -78	36
CSA6659001	B -15	6		AA1 -34	78		AA2 -13	82	CSA6880001	L -80	36
CSA6661001	C -7	10	CSA6738001	F3 -4	22	CSA6801301	H -49	28	CSA6881001	L -81	36
CSA6662001	C -10	10		AA1 -6	76	CSA6804001	H -57	28	CSA6882001	M -1	38
CSA6667001	C -15	10	CSA6739001	F3 -5	22	CSA6805001	H -58	28	CSA6883101	M -3	38
CSA6668001	C 21	10		F3 -12	22	CSA6806001	H 61	28	CSA6885001	M -5	38
CSA6669001	C -22	10		AA1 -65	78		Sp	103	CSA6886001	M -7	38
CSA6671001	C -23	10	CSA6741001	F3 -6	22	CSA6807001	J -1	30		N -77	42
CSA6673001	C -25	10		AA1 -7	76	CSA6809001	J -3	30	CSA6887001	M -8	38
CSA6674001	C -27	10		Sp	102	CSA6810001	J -4	30	CSA6888001	M -12	38
CSA6676001	C -31	10	CSA6742001	F3 -7	22	CSA6812001	J -11	30	CSA6890001	M -14	38
CSA6677001	D -1	12		AA1 -8	76	CSA6814001	J -13	30	CSA6891001	M -19	38
CSA6678001	D -2	12		Sp	101	CSA6815001	J -16	30	CSA6892001	M -21	38
CSA6682001	D 7	12	CSA6743001	F3 -54	22	CSA6817001	J 18	30	CSA6893001	N -1	40
CSA6684001	D -8	12		AA1 -79	80	CSA6819001	J -22	30	CSA6896001	N -5	40
CSA6685001	D -9	12		AA5 -104	94	CSA6821001	J -25	30	CSA6897001	N -6	40
CSA6686001	D -11	12	CSA6744001	G -1	24	CSA6822001	J -29	30	CSA6898001	N -7	40
CSA6687001	D -14	12	CSA6745001	G -2	24	CSA6823001	J -31	30	CSA6899001	N -8	40
CSA6688001	D -16	12	CSA6747001	G -5	24	CSA6824001	J -32	30	CSA6900001	N -12	40
CSA6691001	D -18	12	CSA6748001	G -6	24	CSA6825001	J -33	30	CSA6901101	N -13	40
CSA6692001	D -20	12	CSA6749001	G -7	24	CSA6826001	J -34	30	CSA6902001	N -20	40
CSA6693001	D -21	12	CSA6750001	G -9	24	CSA6827001	J -35	30	CSA6903001	N -24	40
CSA6694001	D -24	12	CSA6751101	G -11	24	CSA6828001	K -1	32	CSA6904001	N -25	40
CSA6695001	E -4	14	CSA6752101	G -12	24	CSA6829001	K -4	32	CSA6906001	N -27	40
CSA6699001	E -13	14	CSA6753001	G -19	24	CSA6830001	K -5	32	CSA6907001	N -28	40
CSA6702001	E -14	14	CSA6754001	G -20	24	CSA6831001	K -6	32	CSA6908001	N -29	40
CSA6703001	E -16	14	CSA6755001	G -25	24	CSA6832101	K -18	32	CSA6909001	N -32	40
CSA6704001	E -18	14	CSA6756001	G -27	24	CSA6833001	K -19	32	CSA6910001	N -33	40
CSA6705001	E -20	14	CSA6757001	G -29	24	CSA6834001	K -8	32	CSA6911001	N -38	40
CSA6707001	E -21	14	CSA6760001	G -32	24	CSA6835001	K -9	32	CSA6912001	N -44	40
CSA6711001	E -24	14	CSA6761001	G -36	24	CSA6836001	K -10	32	CSA6913001	N -45	40
CSA6712001	F -30	14	CSA6762001	G -38	24	CSA6837001	K -12	32	CSA6914001	N -48	40
CSA6713001	E -31	14	CSA6763001	G -40	24	CSA6838001	K -14	32	CSA6915001	N -50	40
CSA6714001	E -32	14	CSA6764001	G -41	24	CSA6839001	K -15	32	CSA6918001	N -51	40
CSA6718001	AA2 -3	82	CSA6765001	G -43	24	CSA6840001	K -16	32	CSA6919001	N -52	40
CSA6719001	F1 -103	18	CSA6766001	G -46	24	CSA6841001	L -1	34	CSA6920001	N -56	40
	AA2 -4	82	CSA6767001	G -47	24	CSA6844001	L -3	34	CSA6922001	N -59	40
CSA6720001	F1 -105	18	CSA6768001	G -53	24	CSA6845001	L -5	34	CSA6923001	N -61	40
	AA2 -6	82	CSA6769001	G -60	24	CSA6848001	L -7	34	CSA6924001	N -62	40
CSA6721001	F1 -108	18	CSA6770001	G -61	24	CSA6849001	L -8	34	CSA6925001	N -63	40
	AA2 -9	82	CSA6771001	G -63	24	CSA6851001	L -11	34	CSA6926001	N -64	40
CSA6726001	F1 -111	18	CSA6772001	G -65	26	CSA6852001	L -12	34	CSA6927001	N -65	40
	AA2 -11										







