

GC6880

INSTRUCTION BOOK



HIGH SPEED 1-NEEDLE FLATBED SEWING MACHINE



TYPICAL

※ This book was prepared based on information available in October 2005.

INSTRUCTION MANUAL

To get the most out of the many functions of this machine and operate it in safely, it is necessary to use this machine correctly.

Please read this Instruction Manual carefully before use. We hope you will enjoy the use of your machine for a long time.

Please remember to keep this manual in a safe place

1. observe the basic safety measures, including, but not limited to the following ones, whenever you use the machine.
 2. Read all the instructions, including, but not limited to this Instruction Manual before you use the machine, In addition, keep this Instruction Manual so that you may read it at anytime when necessary.
 3. Use the machine after it has been ascertained that it conforms with safety rules/standards valid in your country.
 4. All safety devices must be in position when the machine is ready for work or in operation
The operation without the specified safety devices is not allowed.
 5. This machine shall be operated by appropriately-trained operators.
 6. For your personal protection, we recommend that you wear safety glasses.
 7. For the following, turn off the power switch or disconnect the power plug of the machine from the receptacle.
 - 7-1 For threading needle (s) and replacing bobbin.
 - 7-2 For replacing part (s) of needle, presser foot, throat plate, feed dog, cloth guide etc.
 - 7-3 For repair work,
 - 7-4 For when leaving the working place or when the working place is unattended.
 8. If you should allow oil, grease, etc. used with the machine and devices to come in contact with your eyes or skin or swallow any of such liquid by mistake, immediately wash the contacted areas and consult a medical doctor.
-
9. Tampering with the live parts and devices, regardless of whether the machine is powered, is prohibited.
 10. Repairing, remodeling and adjustment works must only be done by appropriately trained technicians or specially skilled personnel.
 11. General maintenance and inspection works have to be done by appropriately trained personnel.
 12. Repair and maintenance works of electrical components shall be conducted by qualified electric technicians or under the audit and guidance of specially skilled personnel.
Whenever you find a failure of any of electrical components, immediately stop the machine,
 13. Periodically clean the machine throughout the period of use.

14. Grounding the machine is always necessary for the normal operation of the machine. The machine has to be operated in an environment that is free from strong noise sources such as high-frequency welder.

15. An appropriate power plug has to be attached to the machine by electric technicians, Power plug has to be connected to grounded receptacle.

16. The machine is only allowed to be used for the purpose intended. Other uses are not allowed.

17. Remodel or modify the machine in accordance with the safety rules/standards while taking all the effective safety measures. We assume no responsibility for damage caused by remodeling or modification of the machine.

18. Warning hints are marked with the two shown symbols.



Danger of injury to operator or service staff



Items requiring special attention

FOR SAFE OPERATION



1. To avoid electrical shock hazards, neither open the cover of the electrical box for the motor nor touch the components mounted inside the electrical box.



1. To avoid personal injury ,never operate the machine with any of the belt cover, finger guard of safety devices removed.
2. To prevent possible personal injuries caused by being caught in the machine. keep your fingers ,head and clothes away from the handwheel, cover and the motor while the machine is in operation. In addition,place nothing around them.
3. To avoid personal injury,never put your hand under the needle when you turn "ON" the power switch or operate the machine.
4. To avoid personal injury,never pur your fingers into the thread take-up cover while the machine is in operation.
5. The hook rotates at a high speed while the machine is in operation.To prevent possible injury to hands ,be sure to keep your hands away from the vicinity of the hook during operation.In addition,be sure to run OFF the power to the machine when repplacing the bobbin.
6. To aviod possible personal injuries ,be careful not to allow your fingers in the machine when tiling/raising the machine head.
7. To avoid possible accidents because of abrupt start of the machine,turn OFF the power to the machine when tiling the machine head .
8. If your machine is equipped with a serve-motor,the motor does not produce noise while the machine is at rest.To avoid possible accidents due to abrupt start of the machine ,be sure to turn OFF the power to the machine .
9. To avoid electrical shock hazards,never operate the sewing machine with the ground wire for the power supply removed.
10. To prevent possible accidents because of electric shock or damaged electrical component(s),turn OFF the power switch in prior to the connection/disconnecti on of the power plug.

CONTENTS

1. BEFORE OPERATION.....	20
2. OPERATION PRECAUTIONS.....	20
3. CHIEF TECHNICAL SPECIFICATIONS.....	20
4. INSTALLATION.....	21
5. LUBRICATION.....	21
6. ADJUSTING THE AMOUNT OF OIL(OIL SPLASHES)IN THE HOOK.....	22
7. ATTACHING THE NEEDLE.....	23
8. SETING THE BOBBIN INTO THE BOBBIN CASE.....	23
9. THREADING THE MACHINE HEAD.....	24
10. WINDING THE BOBBIN.....	24
11. ADJUTING THE STITCH LENGTH.....	24
12. INSTALLING THE TIhread STAND.....	25
13.1.REPLACE THE COUNTER KNIFE AND MOVING KNIFE(ROUND KNIFE).....	25
13.2.ADJUSTING THE THREAD TRIMMING EQUIPMENT(FIG 17.2)(ROUND KNIFE).....	26
13.3.REPLACE THE COUNTER KNIFE AND MOVING KNIFE(STRAIGHT KNIFE).....	27
14. ADJUSTING THE HEIGHT OF THE KNEE LIFTER.....	27
15. PEDAL OPERTION.....	28
16. THREAD TENSION.....	29
17. THREAD TAKE-UP SPRING.....	29
18. HAND LIFTER.....	29
19. PRESSER FOOT PRESSURE.....	30
20. ADJUSTING THE FEED TIMING.....	30
21.1.TILT THE FEED DOG (ROUND KNIFE).....	30
21.2.TILT THE FEED DOG (STRAIGHT KNIFE).....	31
22.1.HEIGHT OF THE FEED DOG (ROUND KNIFE).....	31
22.2.HEIGHT OF THE FEED DOG (STRAIGHT KNIFE).....	31
23. NEEDLE-TO-HOOK RELATIONSHIP.....	32
24. ADJUSTNG THE HEIGHT OF THE PRESSER BAR.....	32
25. COUNTER KNIFE.....	32
26. ADJUSTING THE THREAD TAKE -UP STROKE.....	33
27. ADJUSTING THE NEEDLE STOP POSITION.....	33
28. PEDAL PRESSURE AND PEDAL STROKE.....	34
29. ADJUSTMENT OF THE PEDAL.....	34
30. WIPER.....	35

1.BEFORE OPERATION

- 1.In order to resist rust before machine head packing,all parts are smeared with thick rust-resist ant oil.After packing,perhaps in a relativey long storage and transportation period,the oil will harden and absorb dusts.Therefore,it's necessary to clean the oil and dusts with neat soft cloth and gasoline.
- 2.The machine are examined and checked thoroughly before leaving the factory.But in a long jouney, the machine may be shaken intensely and some parts become loose. it's advisable to test again and turn the driving gears with hands so as to make sure if turning is difficult,run foul of each other or if there is non-uniform block or irregular voice.If so,the machine should be adjusted until every part is normal before driving.
- 3.Operation are forbidden before pouring oil in the plate.
- 4.When the machine is in operation,the direction of the upper wheel are anti-clockwise(viewing from the outer part of the upper wheel).
- 5.Confirom the given electric voltage and phase on motor nameplate.
- 6.The date of manufacture is shown on the inspection certification.

2.OPERATION PRECAUTIONS

- 1.When the power supply is open or the machine is operating ,don't touch the machine needle with your hands.
- 2.When the machine is running ,don't stretch your hands in the mat of the thread stitch bar.
- 3.When the machine head is turning and the "V" belt is being disassembled,the electric supply should be cut off.
- 4.When the operator is leaving the machine,cut out the power supply.
- 5.When the machine is running,no heads,hands or any other things are allowed to get close to the uper wheels,"V"belts bobbin winder and motor.
- 6.Not until the machine stops running can you disassemble the belt cover,protection cover or other protecting devices?
- 7.The machine head's surface can't be cleaned with dilutes such as banana oil.
- 8.Don't put your finger into the finger guard when you feed material by hand.

3.CHIEF TECHNICAL SPECIFICATIONS

	Thin materials	Standard typical	thick materials
Sewing material	Thin materials	Light-middle thick materials	middle thick-thick materials
Sewing speed(Max)	4000S.P.M.	5000S.P.M.	3500S.P.M.
Maximum stitch length	4mm	5mm	8mm
Pressure foot lifting high	6mm(standard) 13mm(max)		
Needle	DA x 1#9	DB x 1#9~#18	DP x 5#16~#18
Lukr Cant oil	10#White oil		
Motor Power	220V/500W		

4.INSTALLATION (FIG.1,FIG.2,FIG.3,FIG.4)

1.fixing oil tray

- 1) oil tray should be put at the four corners of the slot in table plate.
- 2) Fix two arm cushion"1"to the"A"side of oil tray"3"(facing the operator).
Fix the two stand bases"2"to the"B"side of oil tray"3"(hinge side),then
fix the oil tray"3"(picture1.picture2)
- 3) Plug the hinge"1"into hole of bed plate,put the machine head on the table
plate,hinge at the sink place and then fix the machine head on cushions
of the four oil tray corners(picture3,picture4).

**attention:in the packing box ,the rubber cushions fixed at the four corner
of oil tray is not for any other usage,just for packaging.**

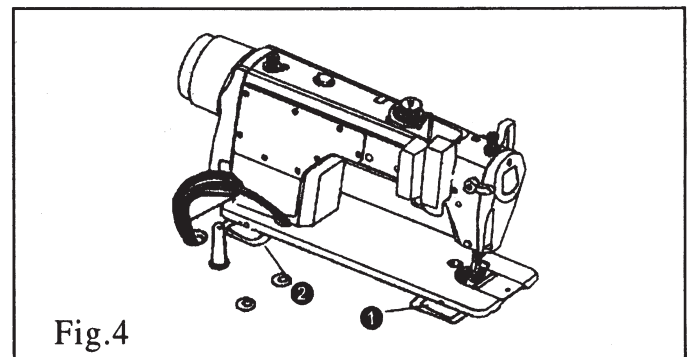
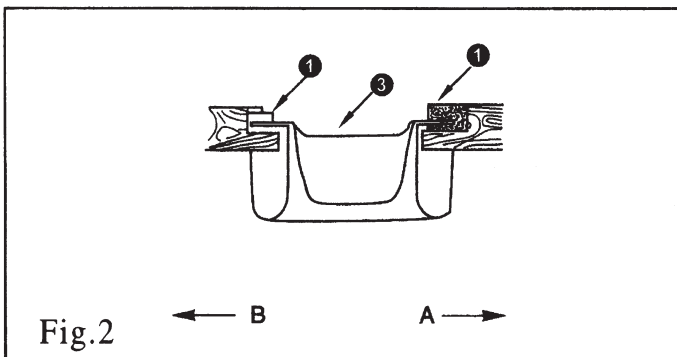
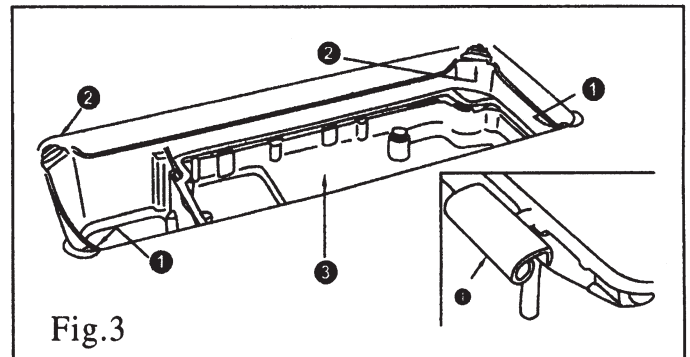
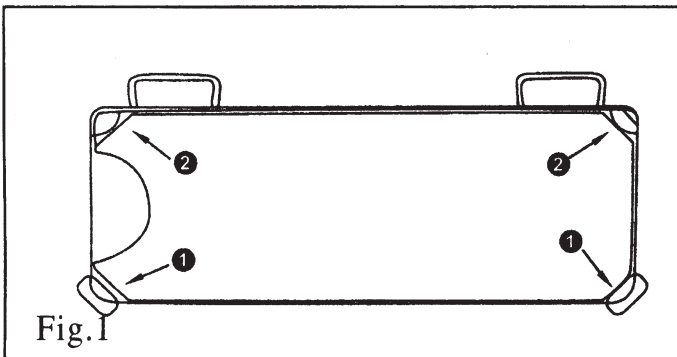

5.LUBRICATION (FIG.5)

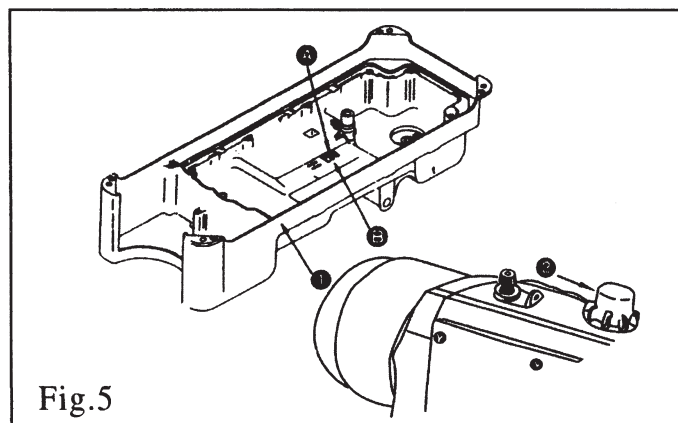

1.Information on lubrication(Fig.5)

- 1) Fill oil pan①with sewing machine oil (10 white oil)up to HIGH mark A.
- 2) when the oil level lowers below LOW mark B,refill the oil pan with the specified oil.
- 3) when you operate the machine after lubrication,you will see splashing oil through oil sight window②if the lubrication is adequate.

4)Note that the amount of the splashing oil is unrelated to the amount of the lubricating oil.

*Precaution

when you first operate your machine after set up or after an extended period of disuse,run your machine at 2,000 sp.m to 2,500s.p.m for about 10 minutes for the purpose of break-in.

6.ADJUSTING THE AMOUNT OF OIL (OIL.SPLASHES) IN THE HOOK(FIG.6.7.8)

① The amount of oil confirmed paper②

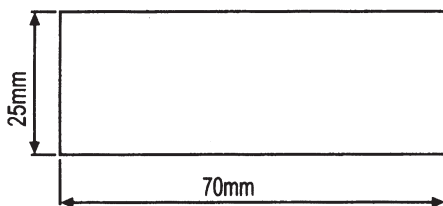

Fig.6

② The place of confirmed

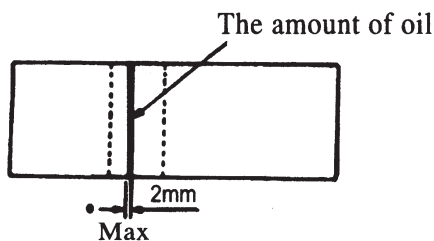
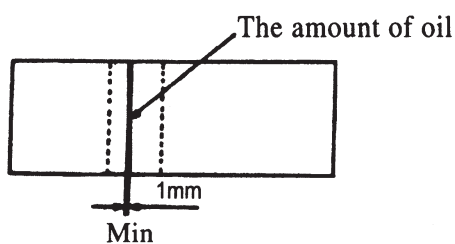
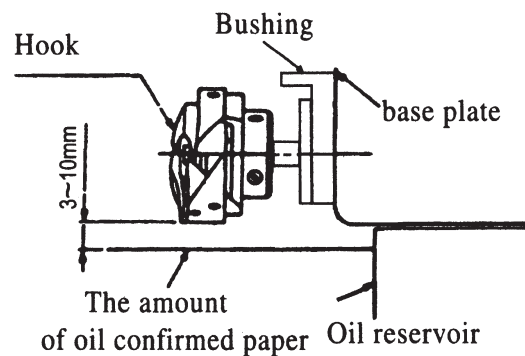

Fig.7

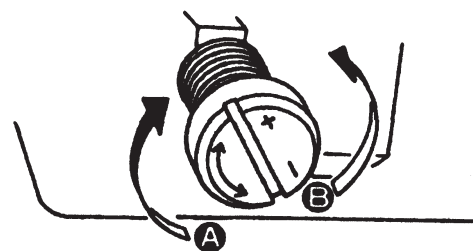

Fig.8

1. Notice before adjustment:

1) The unexpended machine should run without material for around 3 minutes.(or suitable running now and then).

2) Plug in the oil amount paper only when the machine is running.

3) Make sure the oil height in the oil plate ranges between HIGH and LOW.

4) The confirming time of the oil amount is 5 seconds (by manual time -keeping).

2. Appropriate oil amount sample:

1) In the following sample figures, tiny adjustments may be considered according to different sewing process but not too much oil may cause the warming of spinning shuttle and contaminate the material.

2) Try the oil amount paper three times and adjust the oil amount of the spinning shuttle until the oil trail on the paper is stable.

3. Adjust the oil amount of the spinning shuttle:

1) Turning the oil adjusting screw of the front shaft sleeve on bottom shaft towards + direction A, the oil amount will increase ,and towards -direction B, the oil amount will decrease.

2) After adjustment without material for 30 seconds to confirm the condition of the oil amount.

7. ATTACHING THE NEEDLE (FIG. 9)

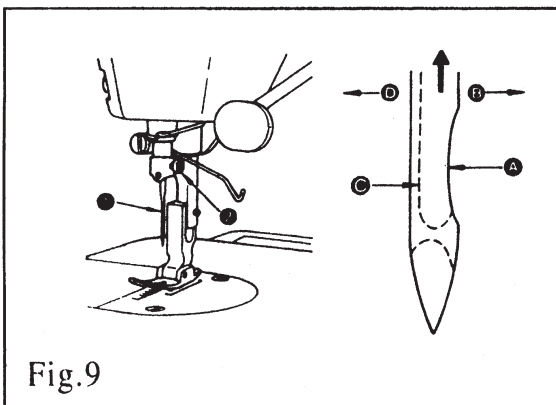

Fig.9

* Turn the motor power OFF before starting to attach the needle.

Select a proper needle size according to the count of thread and the type of material used.

1) Turn the handwheel until the needle bar reaches the highest point of its stroke.

2) Loosen screw ②, and hold needle ① with its indented part A facing exactly to the right in direction B.

3) Insert the needle in the direction of the arrow until it will go no further.

4) Securely tighten screw ②.

5) Check that long groove C of the needle is facing exactly to the left in direction D.

8. SETTING THE BOBBIN INTO THE BOBBIN CASE (FIG. 10)

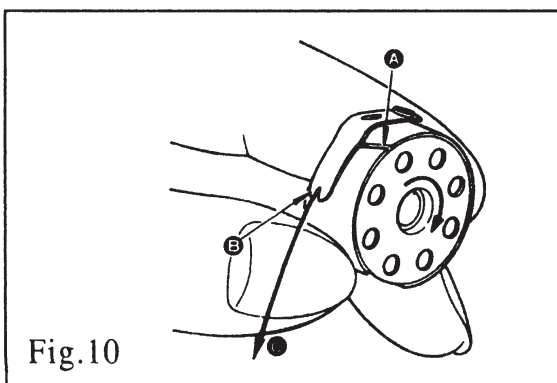

Fig.10

1) Hold the bobbin in a way that the thread open end is directed to the right as observed from you, and set the bobbin into the bobbin case.

2) Pass the thread through thread slit, and pull the thread in direction. By so doing, the thread will pass under the tension spring and come out from notch.

3) Check that the bobbin rotates in the direction of the arrow when thread is pulled.

9.THREADING THE MACHINE HEAD(FIG.11)

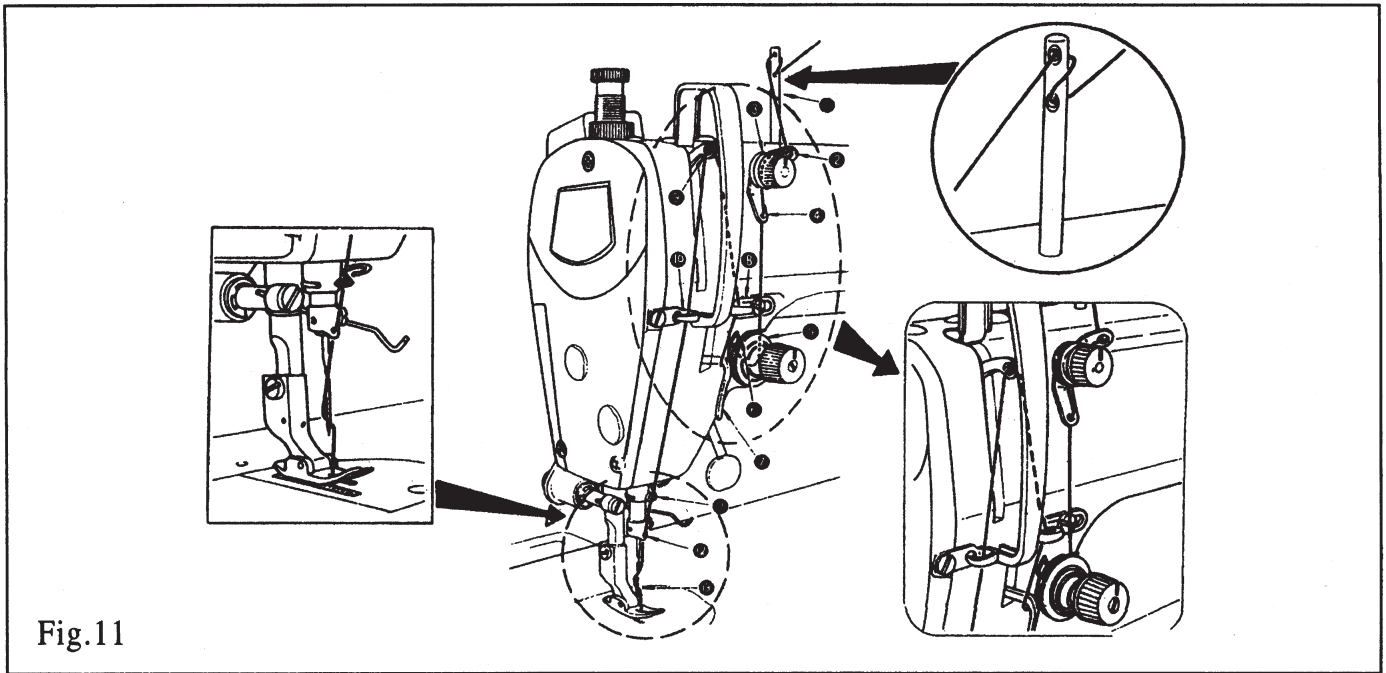

Fig.11

10.WINDING THE BOBBIN(FIG.12)

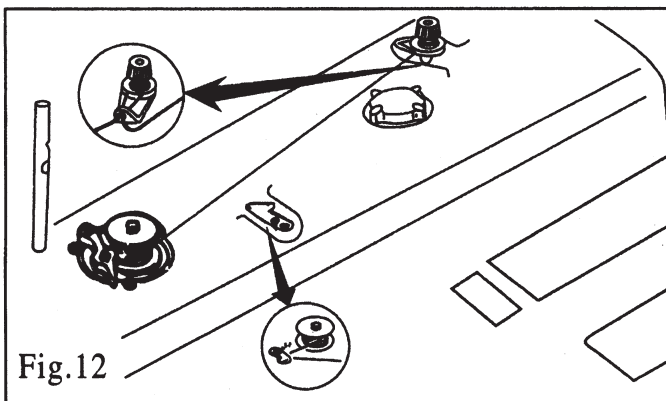

Fig.12

Thread the bobbin winder and wind the bobbin thread onto the bobbin illustrated in the figure 13.

11.ADJUSTING THE STITCH LENGTH(FIG.13)

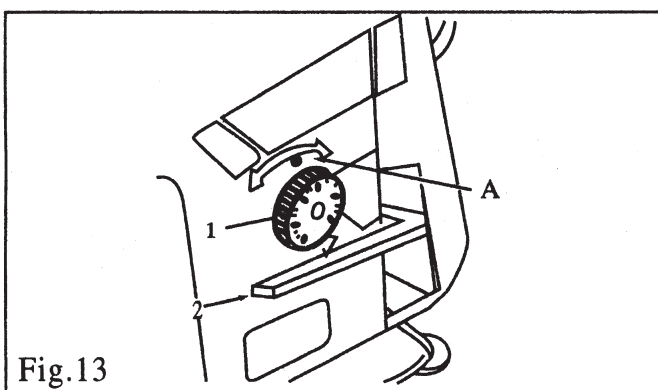

Fig.13

- 1)Turn stitch length dial①in the direction of the arrow,and align the desired number to marker dot ④ on the machine arm.
- 2)The dial calibration is in millimeters.
- 3)when you want to decrease the stitch length, turn stitch length dial①while pressing feed lever②in the direction of the arrow.

12.INSTALLING THE THREAD STAND(FIG.14)

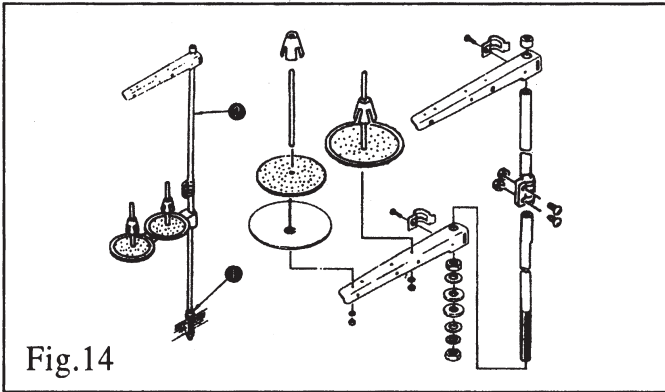

Fig.14

- 1) Assemble the thread stand unit ,and insert it in the hole in the machine table.
- 2) Tighten locknut① to fix the thread stand.
- 3) For ceiling wiring, pass the power cord through spool rest rod②

13.1 REPLACE THE COUNTER KNIFE AND MOVING KNIFE(FIG15,FIG16,FIG17.1)

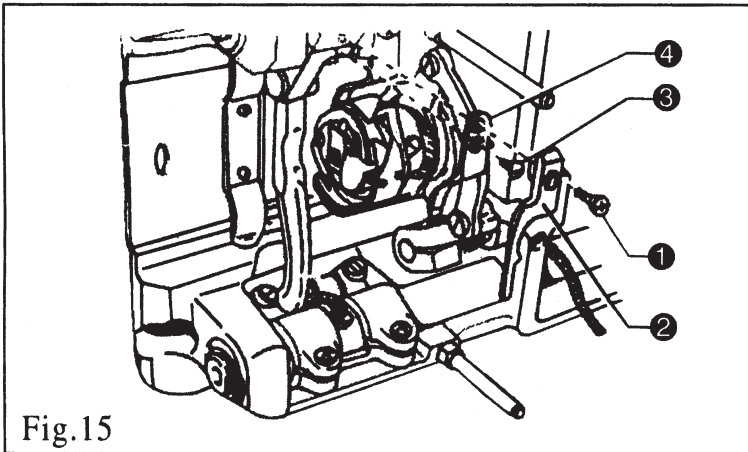

Fig.15

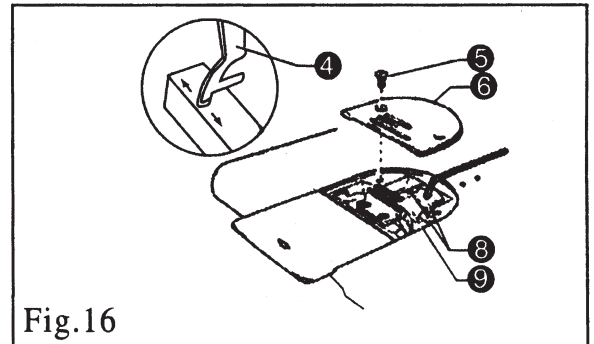

Fig.16

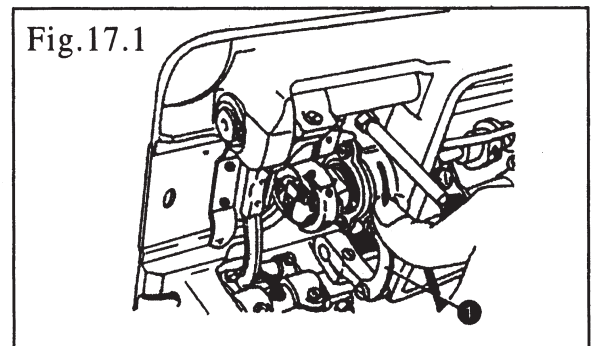

Fig.17.1

1.The method of tearing down the counter knife

- 1).Put down the sewing machine
- 2).Take down the screw ① and positioning finger ②
- 3).take down the screw ③ and counter knife ④ (Fig.16)

※Please the grinding the counter knife when it is not good for cutting thread

2.The method of tearing down the moving knife

- 1).Lifting the presser foot for using hand lifter
- 2).Take down the screw ⑤, put down the needle plate ⑥
- 3).Turn the wheel and stop the needle bar ni its highest posttion
- 4).Drive the knife link ⑦ as illustrated by the arrows , and stop to the position when screw ⑧ is unfolded
- 5).Take down the screw ⑨ and noving knife

Attention:

- 1.Please take down the needle before removing the needle plate and moving knife
- 2).Assemble by reversing sequence

13.2 ADJUSTING THE THREAD TRIMMING EQUIPMENT(FIG17.2)(ROUND KNIFE)

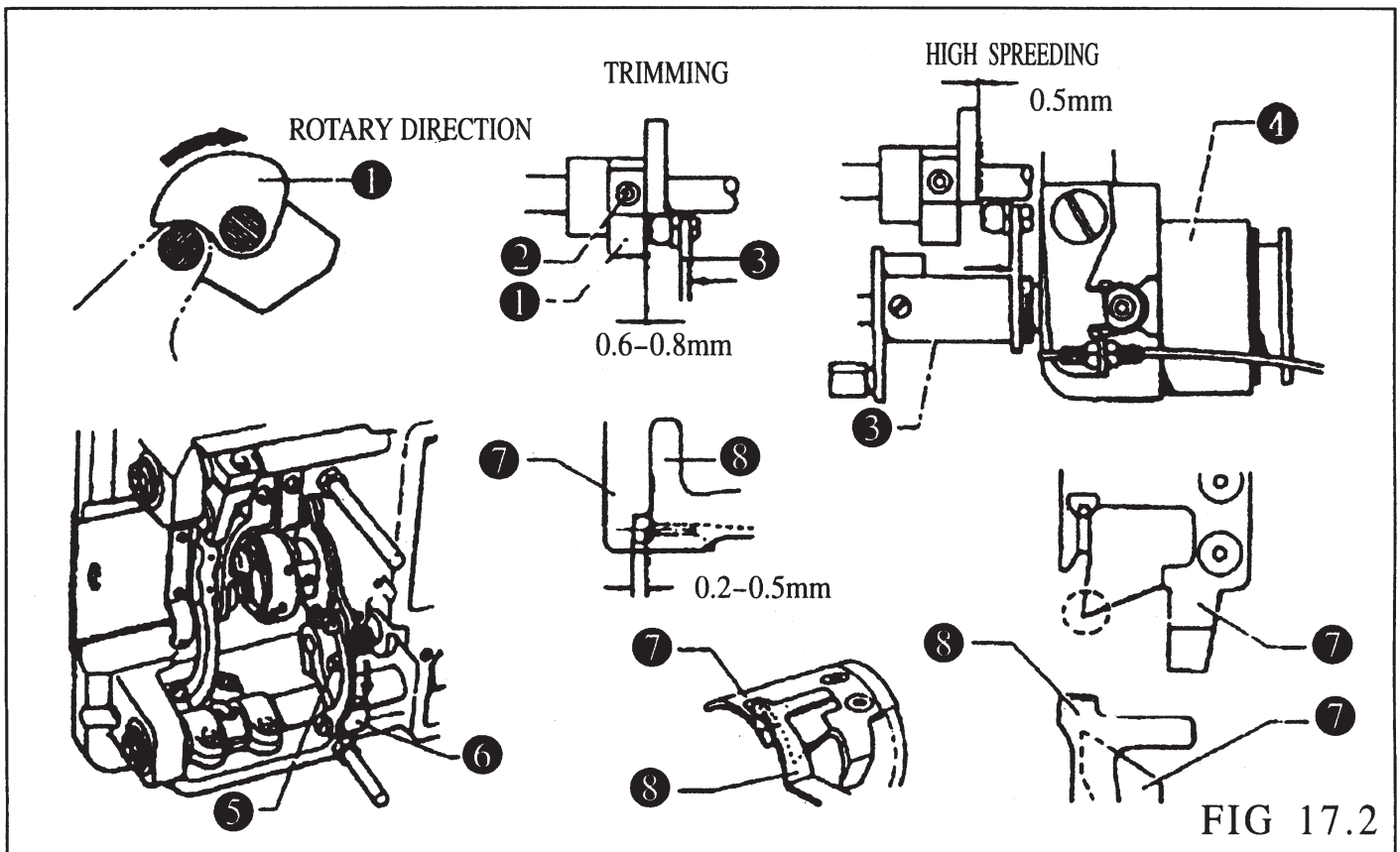

(一) Adjusting the position of the thread trimmng cam.

If you run the handwheel of the machine, the needle bar goes from the bottom up to 5mm, then the thread trimming solenoid④ is pressed to impel the roller ball touches to the concave of the thread trimming cam①, Then use the position screw②to tighten it in casual.And then replace the thread trimming solenoid ④, while loose the screw② to adjust the cam①, the clearance of the end plane between the cam and thread trimming driving shaft is 0.5mm.(Use the torion with 40kg/cm to tighten the position screw②)

(二) Adjusting the position of the counter knife and moving knife.

When the head of the thead trimming driving shaft③ exceeds the cam, the mesh between the front plane of the counter knife⑧and the edge of the moving knife⑦ is 0.2-0.5mm. If they are not meshed,moves the knife shaft crack rod ⑥ before the thread trimming driving shaft exceeded the cam①, the front plane of the counter knife⑧and the edge of the moving knife is meshed, then tighten the screw⑤.

13.3 COUNTER KNIFE(FIG.17.3)(STRAIGHT EDGE)

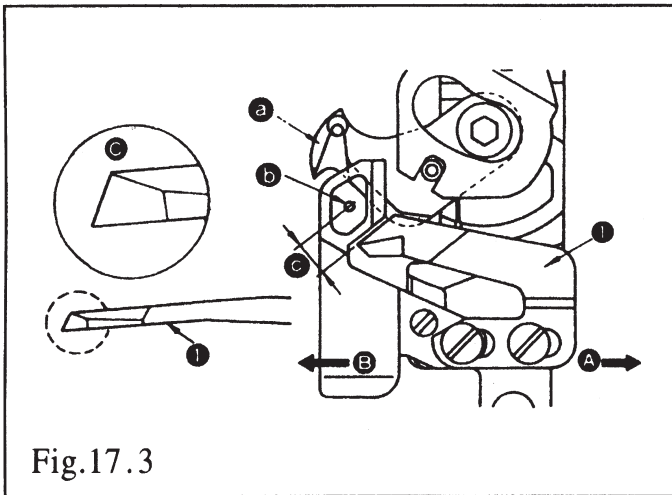

1. When the knife sharpness has deteriorated, resharpen counter knife ① as illustrated in ③, and properly reinstall it.

1) If the mounting position of the counter knife is moved in direction ④ from the standard mounting position, the thread length after thread trimming will be increased accordingly.

2) If the mounting position is moved in direction ⑤, the thread length will be decreased accordingly

④ Moving knife

⑤ Center of needle

③ Standard: 3 to 3.5mm

14. ADJUSTING THE HEIGHT OF THE KNEE LIFTER(FIG.18,19)

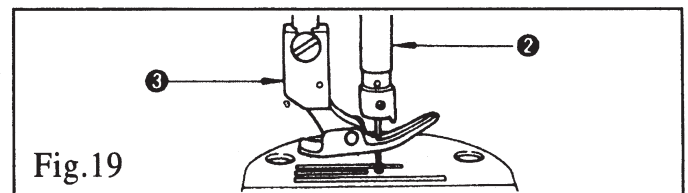
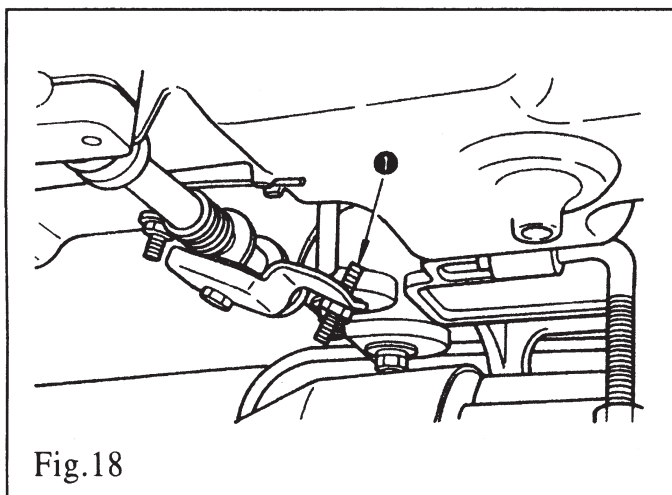

1) The standard height of the presser foot lifted using the knee lifter is 10mm.

2) You can adjust the presser foot lift up to 13mm using knee lifter adjust screw ①. (The max. lift should be 9 mm for the A type.)

3) When you have adjusted the presser foot lift to over 10 mm, be sure that the bottom end of needle bar ② in its lowest position does not hit presser foot ③

15.PEDAL OPERATION(FIG.20)

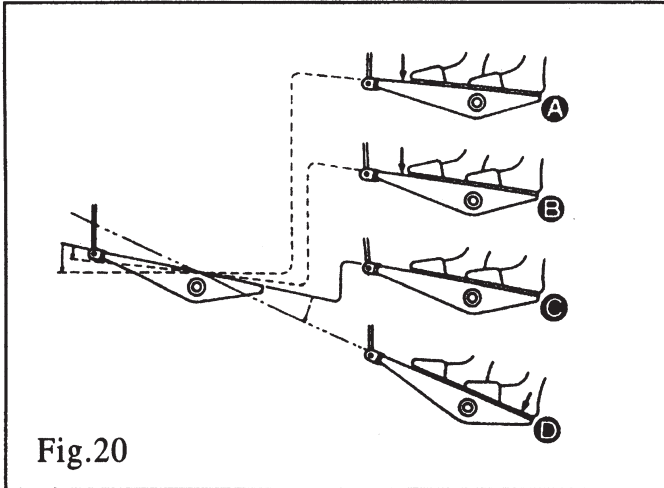
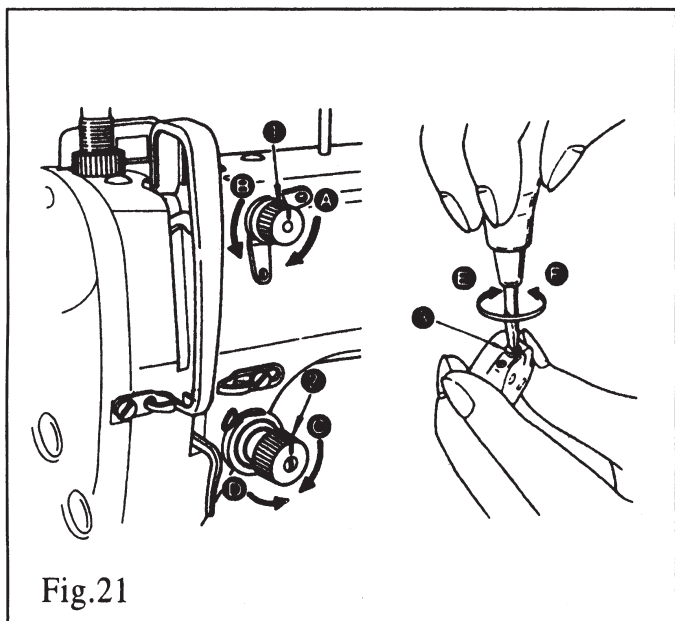

Fig.20

- 1.The pedal is operated in the following four steps:
 - 1)The machine runs at low sewing speed when you lightly depress the front part of the pedal B .
 - 2)The machine runs at high sewing speed when you further depress the front part of the pedal A .
 - 3)The machine stops(with its needle up or down) when you reset the pedal to its original position c .
 - 4)The machine trims threads when you fully depress the back part of the pedal D .

- * The machine will perform normal thread trimming even if you depress the back part of the pedal immediately following high or low speed sewing.
- * The machine will completely perform thread trimming even if you reset the pedal to its neutral position immediately after the machine started thread trimming action.
- * When the machine stops with its needle down ,and if you want to bring the needle up ,depress the back part of the pedal once.
- *-If the machine is fixed with the automatic lifting pressure foot structure,after stopped the machine and delayed two or three seconds,then thrample the threadle backward once,so the pressure foot will lift automatically when the threadle reback,the pressure foot will be down automaticaly.

16.THREAD TENSION(FIG.21)



- 1.Adjusting the needle thread tension
 - 1)As you turn thread tension No.1 nut①clockwise (in directionⒶ),the thread remaining on the needle after thread trimming will be shorter.
 - 2)As you turn nut①counterclockwise(in direction Ⓑ),the thread length will be longer.
 - 3)As you turn thread tension No.2 nut②clockwise (in directionⒸ),the needle thread tension will be increased.
 - 4)As you turn nut②counterclockwise(in direction Ⓓ),the needle thread tension will be decreased.
- 2.Adjusting the bobbin thread tension
 - 1)As you turn tension adjust screw③clockwise(in directionⒺ),the bobbin thread tension will be increased.
 - 2)As you turn screw③counterclockwise(in directionⒻ),the bobbin thread tension will be decreased.

17.THREAD TAKE-UP SPRING(FIG.22)

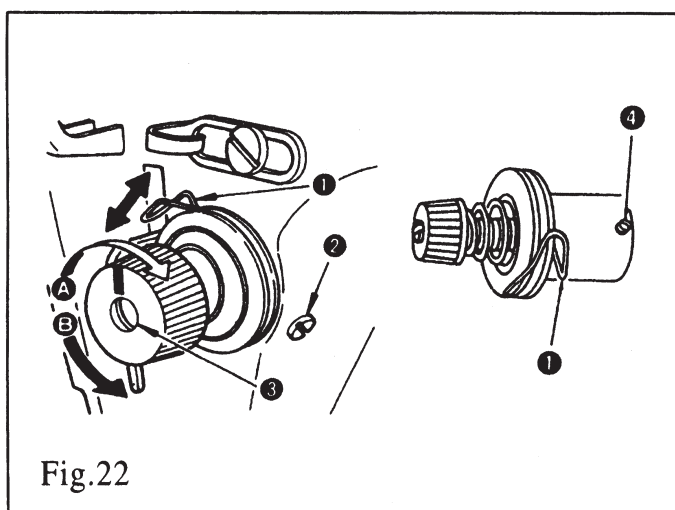

- 1.Changing the stroke of thread take-up spring①
 - 1)Loosen setscrew②.
 - 2)As you turn tension post③ clockwise(in directionⒶ),the stroke of the thread take-up spring will be increased.
 - 3)As you turn the knob counterclockwise(in direction Ⓑ)the stroke will be decreased.
- 2.Changing the pressure of thread take-up spring①
 - 1)Loosen setscrew②,and remove tension post③
 - 2)Loosen setscrew④
 - 3)As you turn tension post③clockwise(in directionⒶ),the pressure will be increased.
 - 4)As you turn the post counterclockwise(in directionⒷ),the pressure will be decreased.

18.HAND LIFTER(FIG.23)

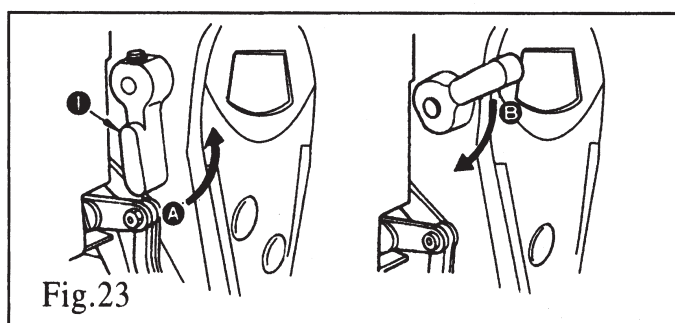

- 1)To stop the machine with its presser foot up,turn hand lifter① in directionⒶ.
- 2)The presser foot will go up about 5.5mm and stop.
- 3)The presser foot will go back to its original position when hand lifter is turned down in directionⒷ.
- 4)Using the knee lifter ,you can get the standard presser foot lift of about 10mm and the maximum lift of about13 mm.

19.PRESSER FOOT PRESSURE(FIG.24)

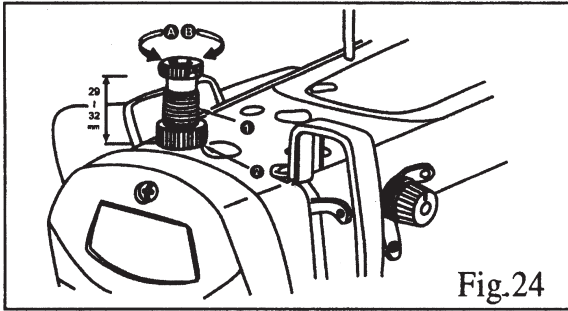

- 1) Loosen nut ②. As you turn presser spring regulator ① clockwise (in direction ④), the presser foot pressure will be increased.
- 2) As you turn the presser spring regulator counterclockwise (in direction ③), the pressure will be decreased.
- 3) After adjustment, tighten nut ②
- 4) For general fabrics, the standard height of the presser spring regulator is 29 to 30mm (5kg).

20.ADJUSTING THE FEED TIMING(FIG.25)

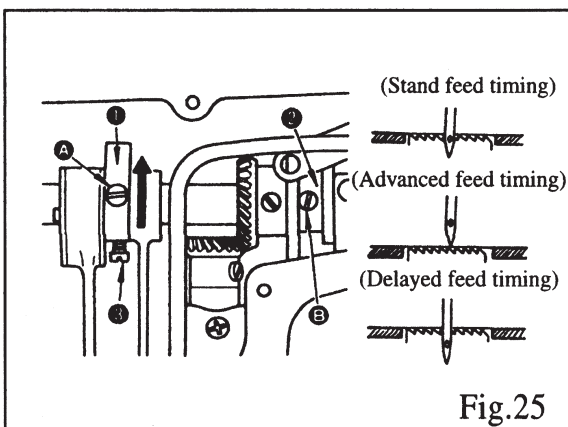

- 1) To obtain the standard feed timing align setscrew ④ on feed eccentric cam ① with setscrew ③ on main shaft thrust collar ②.
- 2) To make adjustment, loosen two setscrews ③ to release the feed eccentric cam, properly position the eccentric cam. Then retighten the setscrews.
- 3) To advance the feed timing in order to prevent uneven material feed, move the feed eccentric cam in the direction of the arrow.
- 4) To delay the feed timing in order to increase stitch tightness, move the feed eccentric cam in the opposite direction for the arrow.
- 5) Be careful not to move the feed eccentric cam too far, or else needle breakage may result.

21.1.TILT THE FEED DOG(FIG.26.1)(ROUND KNIFE)

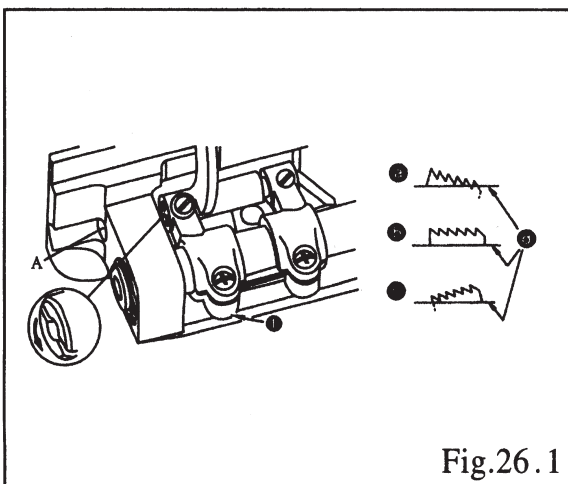

- 1) The standard tilt (horizontal) of the feed dog is obtained when marker dot ④ on the feed bar shaft is aligned with marker dot ③ on feed rocker ①
 - 2) To tilt the feed dog with its front up in order to prevent puckering, loosen the setscrew, and turn the feed bar shaft 90 degrees in the direction of the arrow using a screw driver.
 - 3) To tilt the feed dog with its front down in order to prevent uneven material feed, turn the feed bar shaft 90 degrees in the opposite direction from the arrow.
- (Precaution)** Whenever the feed dog tilt is adjusted, the feed dog height will be changed. So, it is necessary to check the feed dog height after tilt adjustment.

④ Front up ③ Standard ② Front down ① Throat plate

21.2.TILT THE FEED DOG(FIG.26.2)(STRAIGHT EDGE)

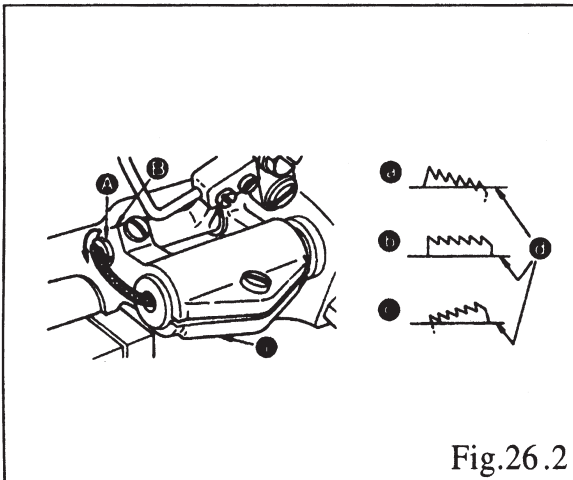

Fig.26.2

① Front up ② Standard ③ Front down ④ Throat plate

1)The standard tilt (horizontal)of the feed dog is obtained when marker dot ④ on the feed bar shaft is aligned with marker dot ① on feed rocker ①

2)To tilt the feed dog with its front up in order to prevent puckering,loosen the serscrew,and turn the feed bar shaft 90 degrees in the direction of the arrow.wsing a screw driver.

3)To tilt the feed dog with its front down in order to prevent uneven material feed,turn the feed bar shaft 90 degrees in the opposite direction from the arrow

(Precaution)Whenever the feed dog tilt is adjusted,the feed dog height will be changed, So,it is necessary to check the feed dog height after tilt adjustment.

22.1.HEIGHT OF THE FEED DOG (FIG.27.1)(ROUND KNIFE)

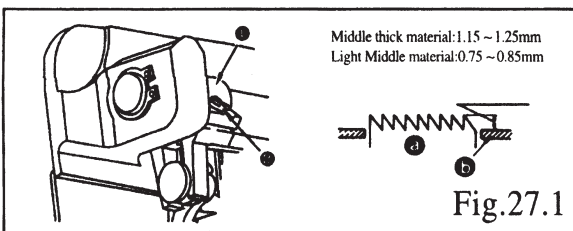

Fig.27.1

① Feed ② Throat plate

1)The feed dog is factory-adjusted so that it just out from the throat plate surface 0.75 to 0.85 mm.For the heavy weight material,it just out 1.15 to 1.25 mm

2)To adjust the height of the feed dog:

①Loosen screw ②of crank ①

②Move the feed bar up or down to make adjustment.

③Securely tighten screw ②.

22.2.HEIGHT OF THE FEED DOG (FIG.27.2)(STRAIGHT EDGE)

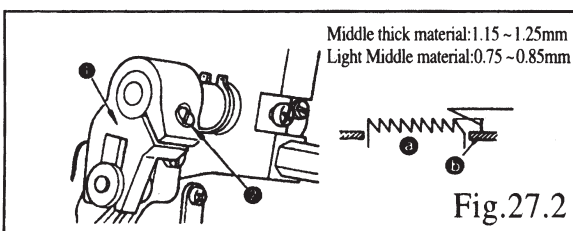

Fig.27.2

① Feed ② Throat plate

1)The feed dog is factory-adjusted so that it just out from the throat plate surface 0.75 to 0.85 mm.For the heavy weight material,it just out 1.15 to 1.25 mm

2)To adjust the height of the feed dog:

①Loosen screw ②of crank ①

②Move the feed bar up or down to make adjustment.

③Securely tighten screw ②.

23.NEEDLE-TO-HOOK RELATIONSHIP(FIG.28)

1.Adjust the timing between the needle and the hook as follows:
1)Turn the handwheel to bring the needle bar down to the lowest point of its stroke, and loosen setscrew ①.

*Adjusting the needle bar height

2)Align marker line A on needle bar②with the bottom end of needle bar lower bushing③, then tighten setscrew ①.

*Adjusting position④of the hook

3)Loosen the two hook setscrews,turn the handwheel,and align marker line B on ascending needle bar②with the bottom end of needle bar lower bushing③.

4)After making the adjustments mentioned in the above steps align hook blade point⑤with the center of needle④.Provide a clearance of 0.04mm to 0.1mm between the needle and the hook,then securely,tighen the hook setscrews.

*Note that the type of hook to be substituted for,when replacing the hook ,shall be in conformity with the very type of the hook installed in the sewing machine of original assemblage.

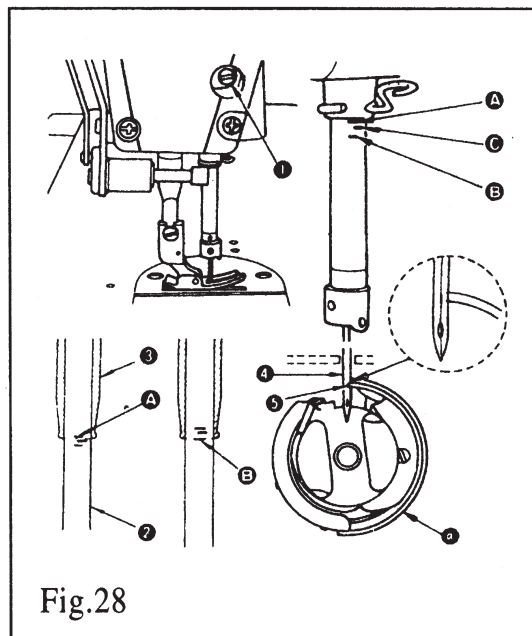

Fig.28

24.ADJUSTING THE HEIGHT OF THE PRESSER BAR(FIG.29)

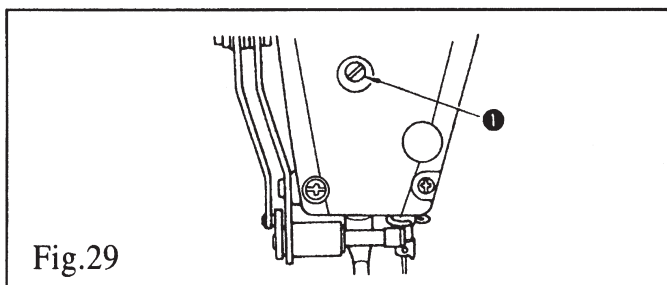

Fig.29

1)Loosen setscrew ①,and adjust the presser bar height or the angle of the presser foot.

2)After adjustment,securely tighten the setscrew.

25.ADJUSTING THE THREAD TAKE-UP STROKE(FIG.30)

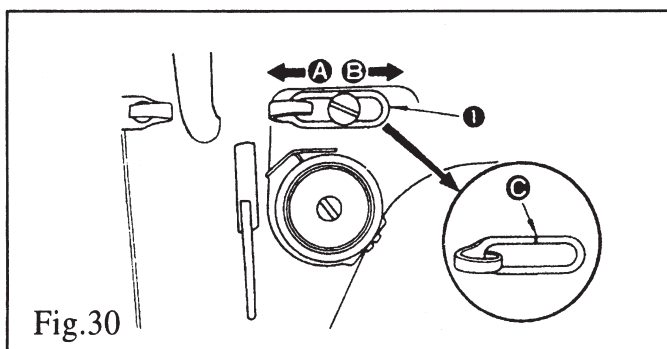

Fig.30

1)When sewing heavy -weight materials, move thread guide①to the left(in directionⒶ) to increase the length of thread pulled out by the thread take-up.

2)When sewing light-weight materials, move thread guide①to the right (in directionⒷ) to decrease the length of thread pulled out by the thread take-up.

3)Normally ,thread guide①is positioned in a way that marker lineⒸ is aligned with the center of the screw.

26. ADJUSTING THE NEEDLE STOP POSITION (FIG.31)

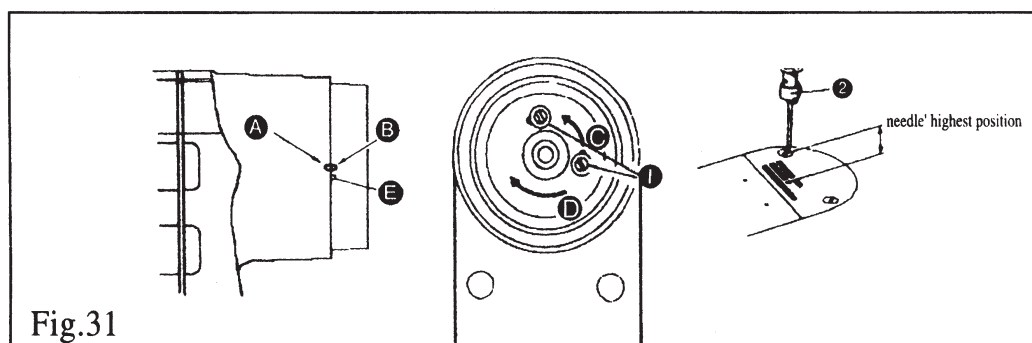

Fig.31

1. Needle position after thread trimming.

After switch on the machine, stop the machine as the needle goes to its highest position and then the distance between the needle plate upper plane and the needlepoint is: middle heavy cloth: 10-20mm (the red point A on the back cover aligns with the red point B on the upper wheel); the heavy cloth: 10-14mm (the red point A aligns with the point E on the upper wheel).

If you want to change the needle position, loose the two fixed screws 1 and then you can adjust it in the long slot.

① If the screw moves to C, the needle bar ② stops at its highest position;

② If the screw moves to D, the needle bar stops at a lower position.

Remarks:

When loose the screw ①, please do not set up the machine; besides, just loose the screw ① not take it off.

2. The needle's lower position

Precaution: Don't adjusting the needle's stop position.

27. PEDAL PRESSURE AND PEDAL STROKE (FIG.32)

1. Adjusting the pressure required to depress the front part of the pedal

1) This pressure can be changed by altering the mounting position of pedaling pressure adjust spring ①.

2) The pressure decreases when you hook the spring on the left side.

3) The pressure increases when you hook the spring on the right side.

2. Adjusting the pressure required to depress the back part of the pedal

1) This pressure can be adjusted using regulator screw ②.

2) The pressure increases as you turn the regulator screw in.

3) The pressure decreases as you turn the screw out.

3. Adjusting the pedal stroke

1) The pedal stroke decreases when you insert connecting rod ③ into the left hole.

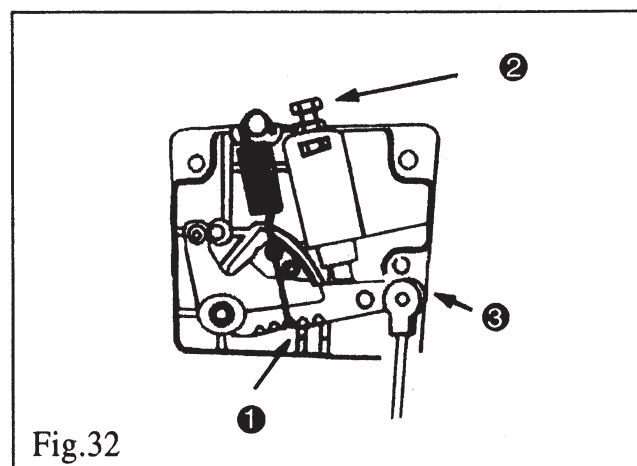

Fig.32

28. ADJUSTMENT OF THE PEDAL (FIG.33)

1.Installing the connecting rod

1)Move pedal to the right or left as illustrated by the arrows so that motor control lever and connecting rod are straightened.

2Adjusting the pedal angle

1)The pedal tilt can be freely adjusted by changing the length of the connecting rod.

2)Loosen adjust screw ,and adjust the length of connecting rod.

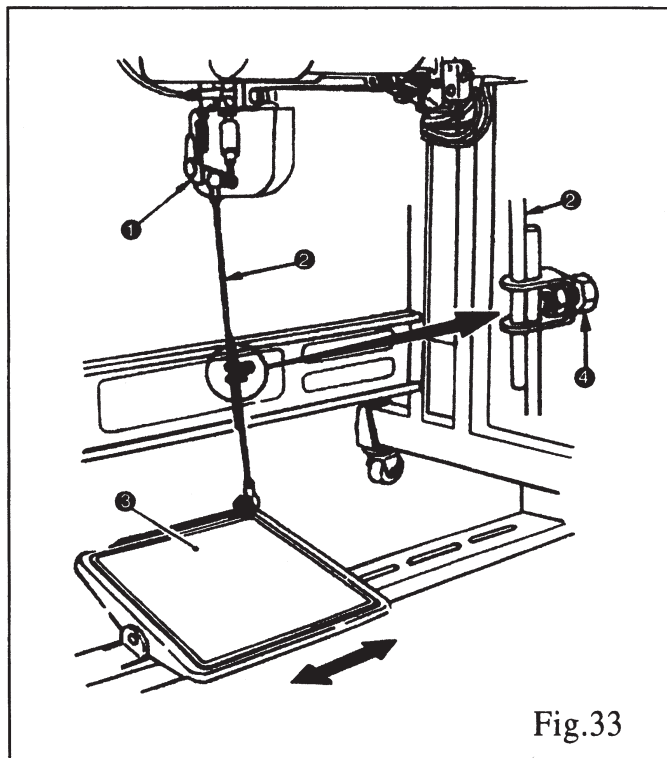

Fig.33

29.ONE-TOUCH TYPE REVERSE FEED STITCHING MECHANISM (FIG.34)

1.How to operate

1)The moment switch lever①is pressed,the machine perform reverse feed stitching.

2)The machine performs reverse feed stitching as long as the switch lever is held depressed.

3)The machine resumes normal feed stitching the moment the switch lever is released .

2.Height of the switch lever

1)Adjust the height of switch lever① so that it can be easily operated.

2)Loosen screw②,and move the switch lever up or down to adjust its height.

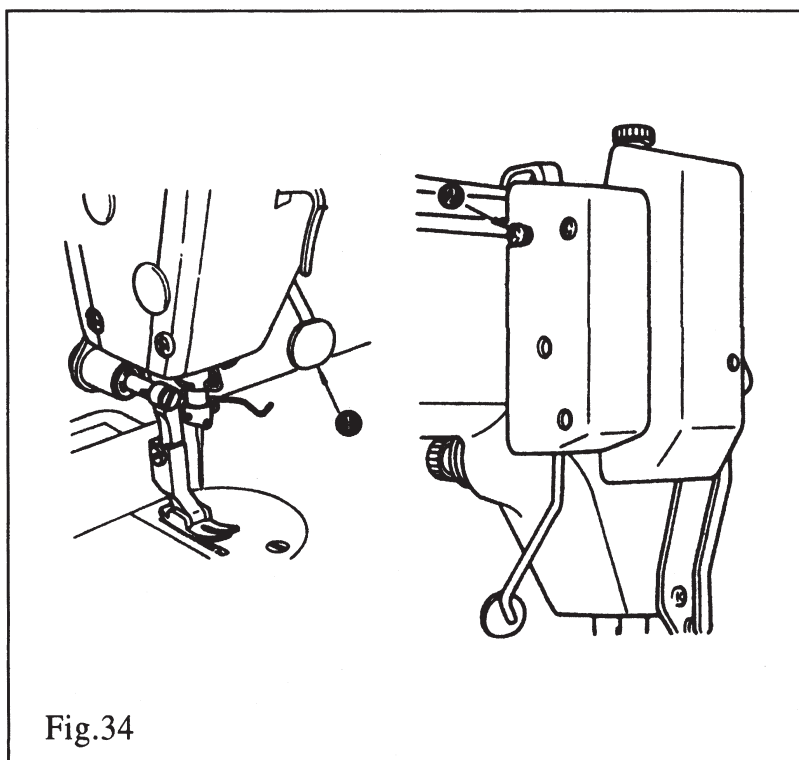
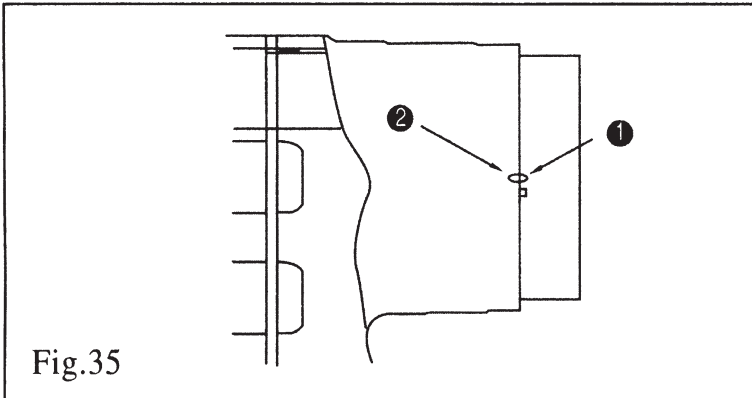

Fig.34

30.WIPER(FIG.35, FIG.36, FIG.37)



1.Positioning the wiper

Adjust the position of the wiper according to the thickness of the material sewn, The adjustment procedure is as follows:

1)Turn the handwheel in the normal direction of rotation to align white marker dot①on the handwheel with red marker dot②on the machine arm.

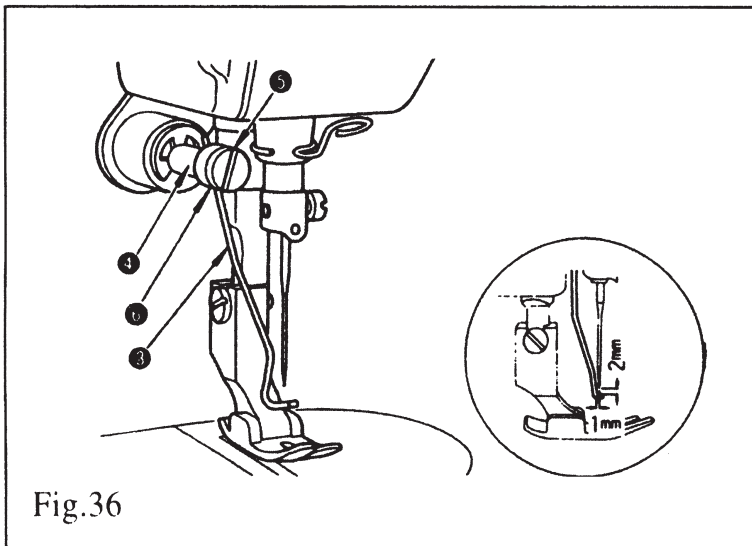

2)Adjust the distance between the flat part of the wiper and the center of the needle to 1mm.Tighten wiper adjust screw ③so that the wiper is pressed and fixed by wiper collar④.

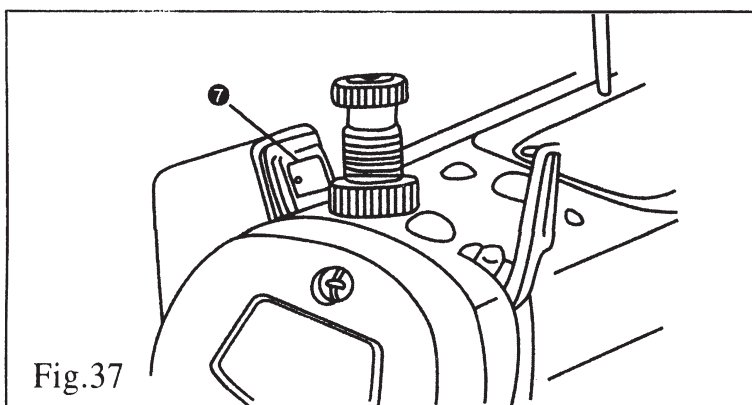

3)When the wiper is unnecessary,turn wiper switch⑦OFF.

GC6880

HIGH SPEED 1-NEEDLE FLATBED SEWING MACHINE



This machine may only be operated by adequately trained operators only after having completely read and understood the instruction manual.

Parts are subject to changes in design without prior notice.



VETRON TYPICAL EUROPE GmbH

Clara-Immerwahr-Str. 6
67661 Kaiserslautern, Germany
Tel.: +49 6301 320 75-0
Fax: +49 6301 320 75-11

info@vetrontypical.com
www.vetrontypical.com